



# Architecture

21045

## Trafalgar Square

London, Great Britain

Londres, Grande-Bretagne

Londres, Gran Bretaña







# A Part of the Fabric of London

## Une partie intégrante du paysage de Londres

### Parte del entramado de Londres

Think of a “London landmark” and Trafalgar Square will quickly come to mind. A public square in the City of Westminster, it is a space that has played a key part in the history and culture of London since the thirteenth century.

Originally called the Royal Mews, the area was re-developed by architect John Nash as a public space for culture and arts and named Trafalgar Square in 1830, to commemorate the British naval victory at the Battle of Trafalgar.

Trafalgar Square remains an arena for national democracy, protests and demonstrations. However, it is also home to festive Christmas and New Year’s Eve celebrations, where people gather around the giant tree that has been donated by Norway every year since 1947.

Trafalgar Square est sans contredit un symbole qui définit Londres. Depuis le 13<sup>e</sup> siècle, cette place publique au cœur de la ville de Westminster a été la scène de plusieurs événements historiques et culturels de Londres.

À l’origine appelé les écuries royales (Royal Mews), l’endroit a été transformé en lieu public de culture et d’art par l’architecte John Nash, puis renommé Trafalgar Square en 1830 pour commémorer la victoire de la marine britannique à la bataille de Trafalgar.

Trafalgar Square est encore aujourd’hui le théâtre de la démocratie nationale où se déroulent protestations et manifestations. Il est aussi le lieu des festivités de Noël et des célébrations du Nouvel An où les gens se rassemblent autour d’un sapin géant offert chaque année par la Norvège depuis 1947.

Al pensar en un lugar representativo de Londres, Trafalgar Square viene a la mente de inmediato. Esta plaza pública de la ciudad de Westminster ha interpretado un papel determinante en la historia y la cultura de Londres desde el siglo XIII.

Conocida originalmente como Caballerizas Reales, la zona fue reconvertida por el arquitecto John Nash en un espacio público dedicado a la cultura y las artes, y bautizada como Trafalgar Square en 1830 para conmemorar la victoria de la Armada británica en la batalla de Trafalgar.

Trafalgar Square es hoy escenario de la democracia nacional y suele concentrar protestas y manifestaciones. Sin embargo, el lugar es también un popular punto de encuentro durante las celebraciones de Navidad y Año Nuevo, que reúnen a la gente alrededor del enorme árbol donado por Noruega desde 1947.

# The National Gallery

## La National Gallery

## La Galería Nacional

The National Gallery houses collections of important paintings from the mid thirteenth century until 1900. William Wilkins designed and built the imposing building between 1832 and 1838 on the site of the former Royal Mews; the location was important as it allowed all classes and neighborhoods to access the art.

Although the front façade remains almost the same, the building itself has changed and evolved since then, including the development of the post-modern Sainsbury Wing extension to the west.

La National Gallery abrite des collections de tableaux importants datant du milieu du 13<sup>e</sup> siècle jusqu'à 1900. William Wilkins a conçu et réalisé l'imposant bâtiment entre 1832 et 1838 sur le site des anciennes écuries royales. L'emplacement importait, car il permettait aux gens de toutes les classes et de tous les quartiers d'avoir accès à l'art.

Bien que la façade soit encore presque la même, le bâtiment a changé et évolué au fil du temps, avec l'ajout par exemple de l'aile Sainsbury de style post-moderne à l'ouest.

La Galería Nacional alberga importantes colecciones de pintura que abarcan desde mediados del siglo XIII hasta 1900. William Wilkins diseñó y construyó el majestuoso edificio entre 1832 y 1838 en donde estaban las antiguas Caballerizas Reales; la ubicación era importante, ya que ofrecía acceso al arte a todas las clases sociales y vecindarios.

Aunque la fachada principal es prácticamente la misma de entonces, el edificio en sí ha cambiado y evolucionado para incorporar, por ejemplo, el Ala Sainsbury de arte posmoderno, que se extiende hacia el oeste.





# Nelson's Column

## La colonne Nelson

## La Columna de Nelson

This monument was created by architect William Railton to honor Admiral Horatio Nelson, who led the British to victory and died at the Battle of Trafalgar. The iconic Corinthian column was completed in 1854, but the four majestic lions that guard the sculpture were installed many years later, in 1867.

Ce monument a été créé par l'architecte William Railton en l'honneur de l'amiral Horatio Nelson, qui a conduit les Britanniques à la victoire pour ensuite mourir lors de la bataille de Trafalgar. L'emblématique colonne corinthienne a été achevée en 1854, et les quatre majestueux lions qui gardent la sculpture ont été installés plusieurs années plus tard, en 1867.

Este monumento fue creado por el arquitecto William Railton en honor al almirante Horatio Nelson, quien guio a los británicos hacia la victoria y murió en la batalla de Trafalgar. La famosa columna corintia fue terminada en 1854, pero los cuatro imponentes leones que custodian la escultura fueron instalados muchos años después: en 1867.





# The Fountains

## Les fontaines

## Las fuentes

Charles Barry originally created the fountains as a way of offsetting the glare and heat reflected on the large amounts of asphalt surface on the square. The centerpieces were replaced in the 1930s as memorials to naval officers, Lord Jellicoe and Lord Beatty, with the old centerpieces being gifted to the Canadian government.

Charles Barry a créé les fontaines à l'origine dans le but de compenser la chaleur réfléchi sur la vaste étendue d'asphalte de la place. Les pièces centrales ont été remplacées dans les années 1930 pour commémorer deux officiers de marine, Lord Jellicoe et Lord Beatty. Les anciens monuments ont été offerts au gouvernement canadien.

En un principio, Charles Barry creó las fuentes para contrarrestar el resplandor y el calor que desprende la extensa superficie de asfalto de la plaza. Las obras ornamentales fueron sustituidas en la década de 1930 por monumentos a los oficiales navales Lord Jellicoe y Lord Beatty; las antiguas piezas fueron obsequiadas al gobierno canadiense.



# The Plinths and Sculptures

## Les socles et les sculptures

## Los pedestales y las esculturas

The eastern plinth has a bronze statue of George IV (nicknamed “the first gentleman of England”) on a horse, created by English sculptor Francis Chantrey and installed in 1844. In 1855 the plinth in the southwest corner received a statue of British Army veteran, Charles James Napier, by sculptor George Gammon Adams. The statue of Sir Henry Havelock, by William Behnes, was placed on the southeast plinth in 1861.

After many years of debate about the fate of the empty ‘Fourth Plinth’, it has since been used for a rotation of temporary modern artworks, a concept initiated by the Royal Society of Arts.



Le socle à l'est présente une statue en bronze de George IV (surnommé « le premier gentilhomme d'Angleterre ») sur un cheval, créée par le sculpteur anglais Francis Chantrey et installée en 1844. En 1855, le socle sud-ouest a accueilli la statue d'un vétéran de l'armée britannique, Charles James Napier, sculptée par George Gammon Adams. La statue de Sir Henry Havelock, créée par William Behnes, a été posée sur le socle sud-est en 1861.

Après plusieurs années de débat sur le sort du « quatrième socle », jusqu'à maintenant laissé à lui-même, la Royal Society of Arts a décidé d'y poser des œuvres modernes temporaires.

El pedestal oriental sostiene una estatua de bronce de Jorge IV (apodado “el primer caballero de Inglaterra”) a caballo, creada por el escultor inglés Francis Chantrey e instalada en 1844. En 1855, el pedestal de la esquina suroeste recibió una estatua del veterano de la Armada británica Charles James Napier, obra del escultor George Gammon Adams. La estatua de Sir Henry Havelock, de William Behnes, fue colocada en el pedestal sureste en 1861.

Luego de muchos años de controversia sobre el destino del cuarto pedestal vacío, comenzó a usarse para la exposición temporal de obras de arte moderno a raíz del concepto promovido por la Royal Society of Arts.

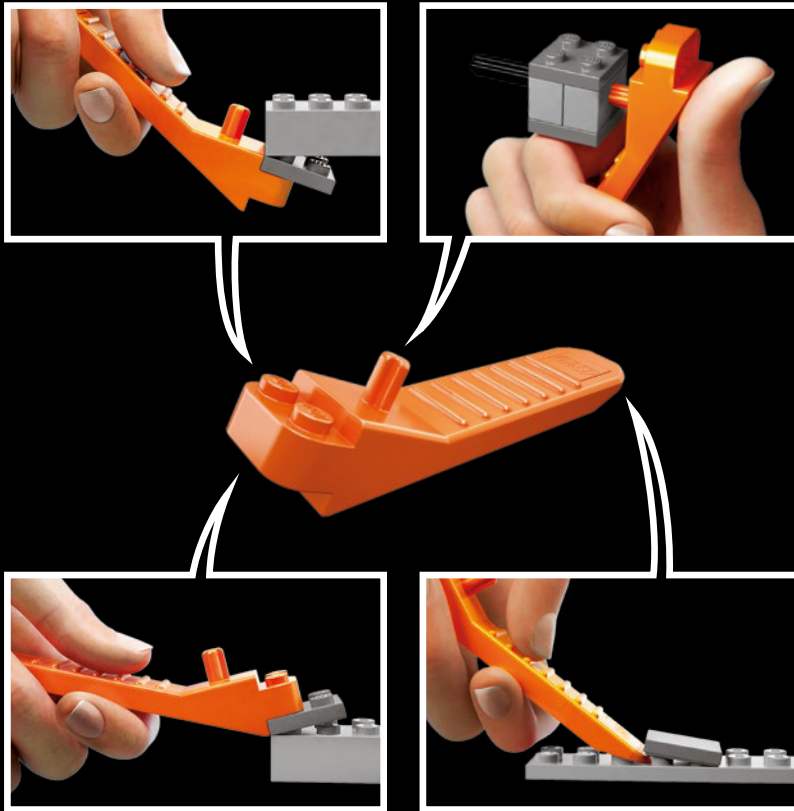





- 1** Download the LEGO® Life App  
 Lade dir die LEGO® Life App herunter  
 Télécharge l'application LEGO® Life  
 Télécharger l'application LEGO® Life  
 Scarica l'app LEGO® Life  
 Descarga la app LEGO® Life  
 Descarrega a App LEGO® Life  
 Töltsd le a LEGO® Life Appot!  
 Lejupielādē lietotni LEGO® Life  
 下載 LEGO® Life 应用程序



- 2** Scan the code on the front cover  
 Scanne den Code auf der Titelseite  
 Scanne le code sur la page de  
 couverture  
 Scanner le code sur la page  
 couverture  
 Scansiona il codice sulla copertina  
 Escanea el código de la portada  
 Faz scan do código na frente da capa  
 Olvasd be a borítón látható kódot!  
 Noskenē kodu uz priekšējā vāka  
 扫描封面上的二维码



- 3** Get the Building Instructions  
 Hol dir die Bauanleitung  
 Obtens les instructions de montage  
 Obtenir les instructions de montage  
 Scarica le istruzioni per la  
 costruzione  
 Consulta las instrucciones de  
 construcción  
 Obtém as Instruções de Construção  
 Szerezd be az építési útmutatókat!  
 Saņem būvēšanas instrukcijas  
 获取拼搭说明

**LEGO.com/apps**

Check for compatibility  
 Kompatibilität prüfen  
 Vérifier la compatibilité  
 Controlla la compatibilità  
 Comprueba tu compatibilidad

Verificar a compatibilidade  
 Ellenőrizd a kompatibilitást  
 Pārbaudīt saderību  
 检查兼容性

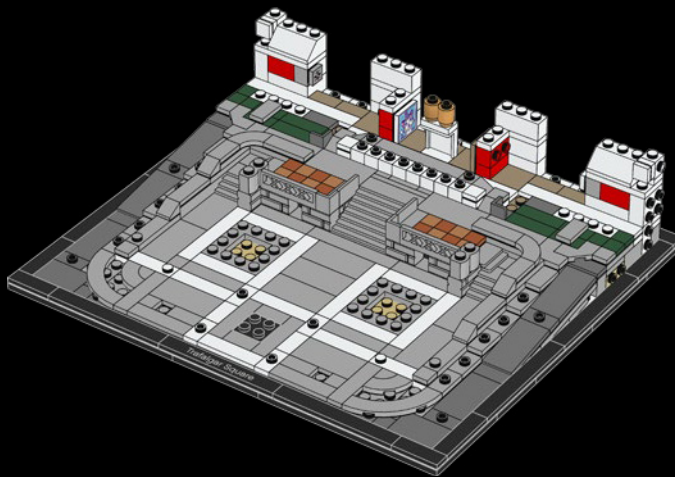
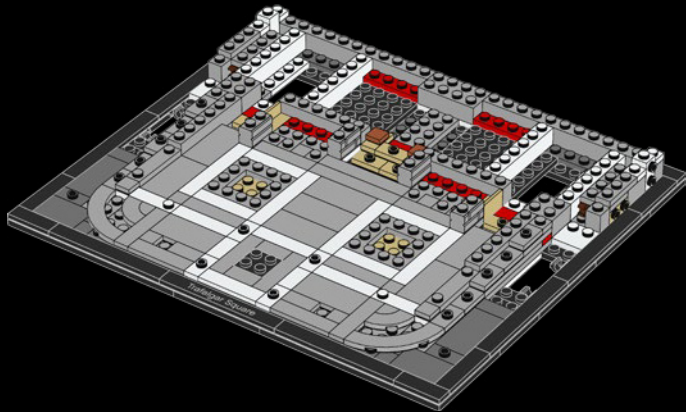



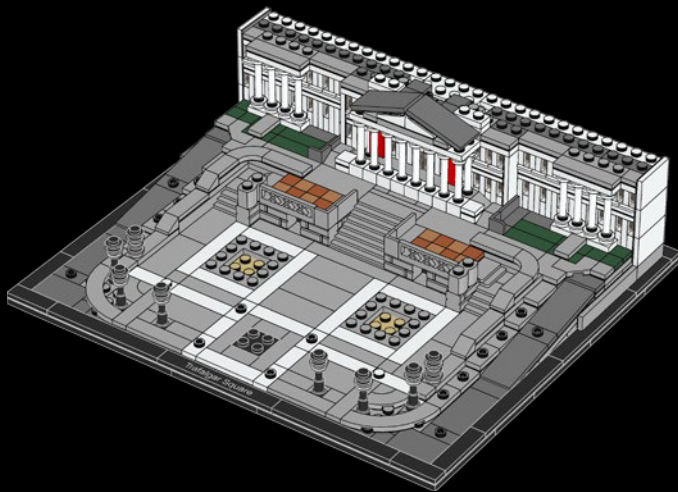

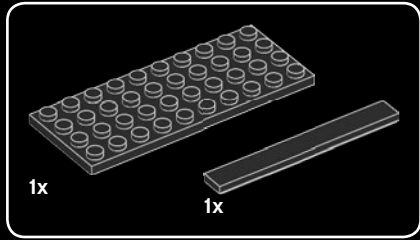
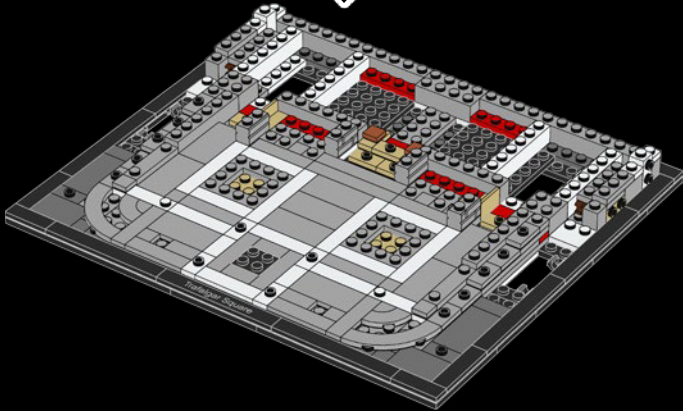
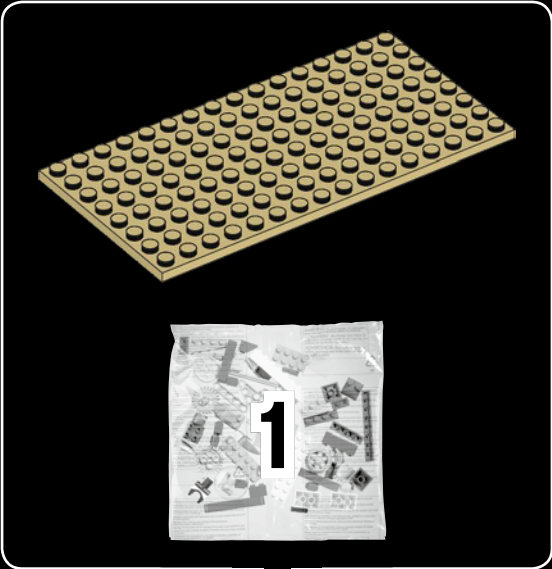

1

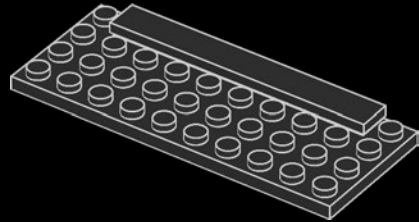

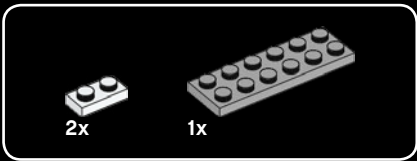

2

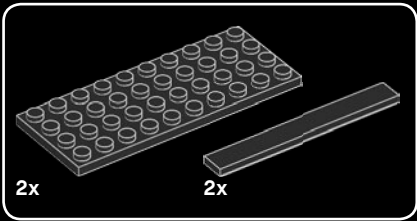
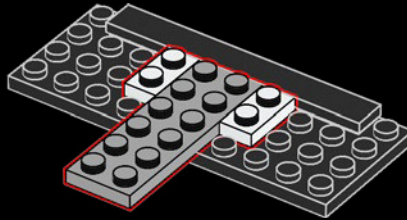

3

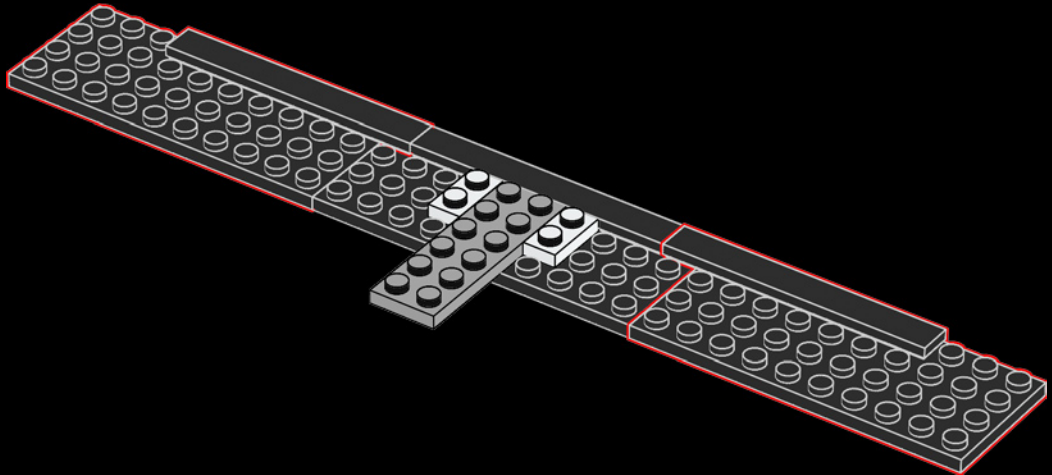

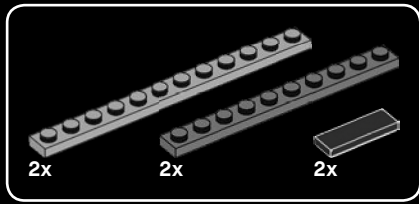

4

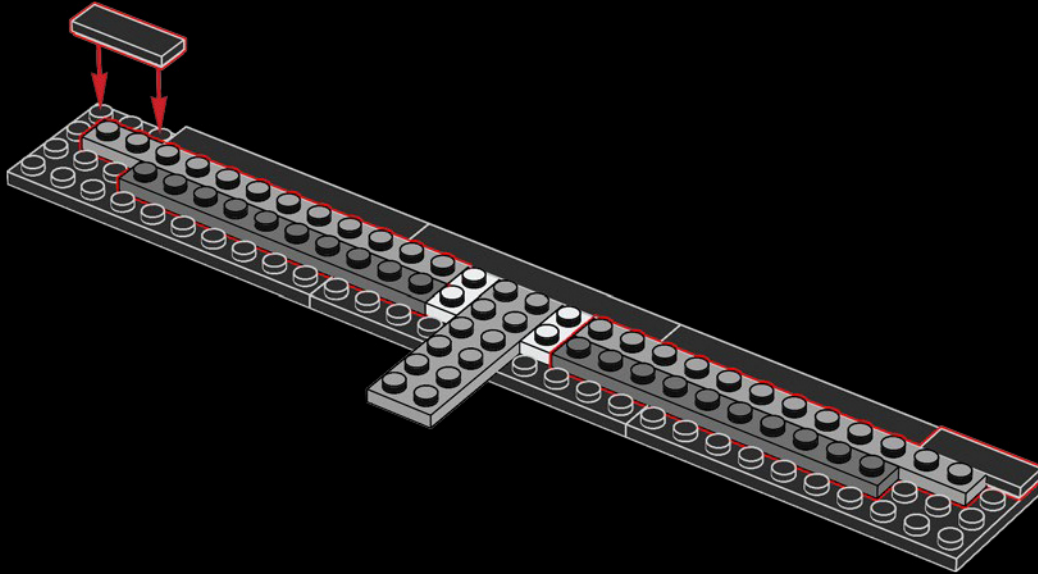



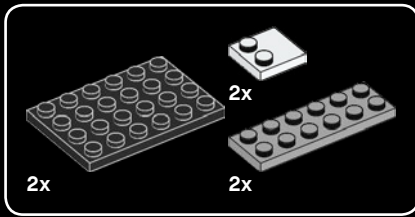

5

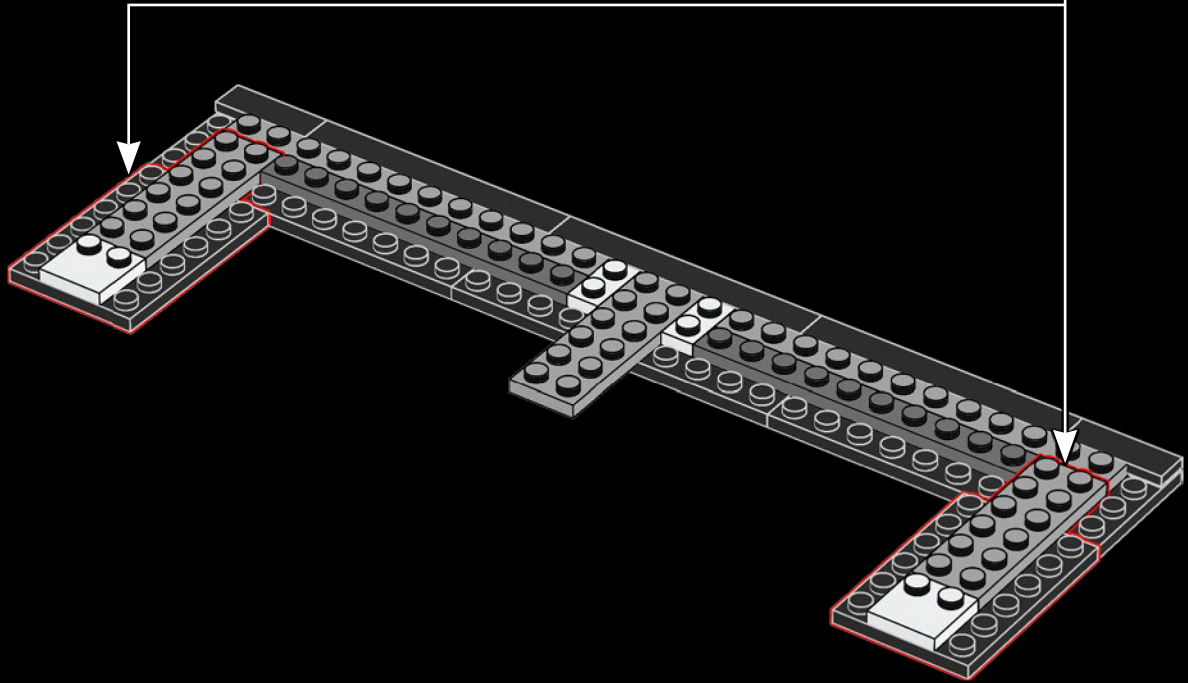
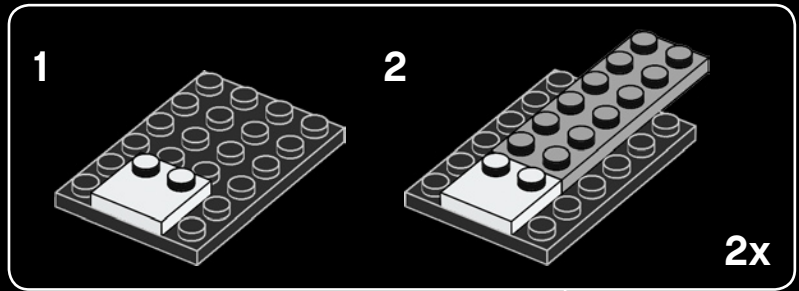

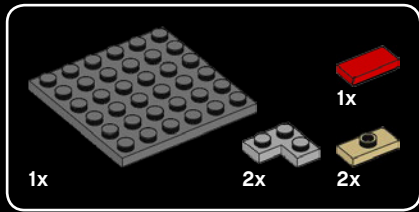

6

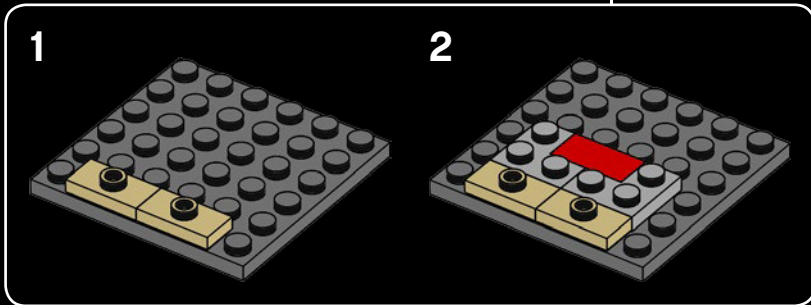
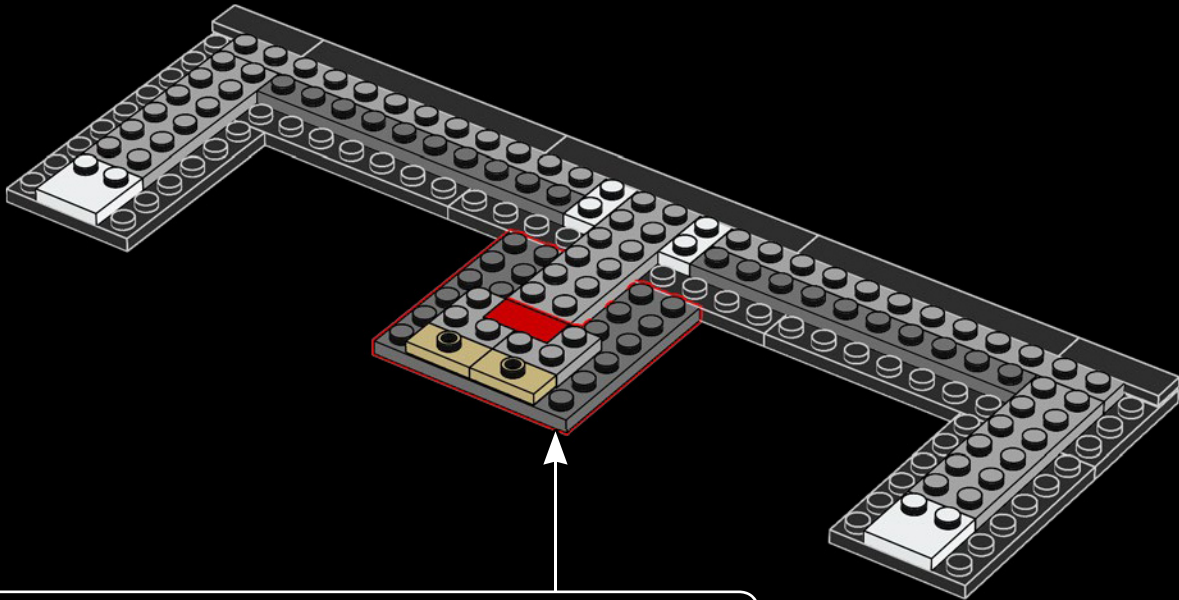

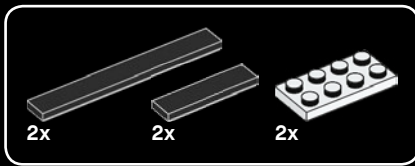

7

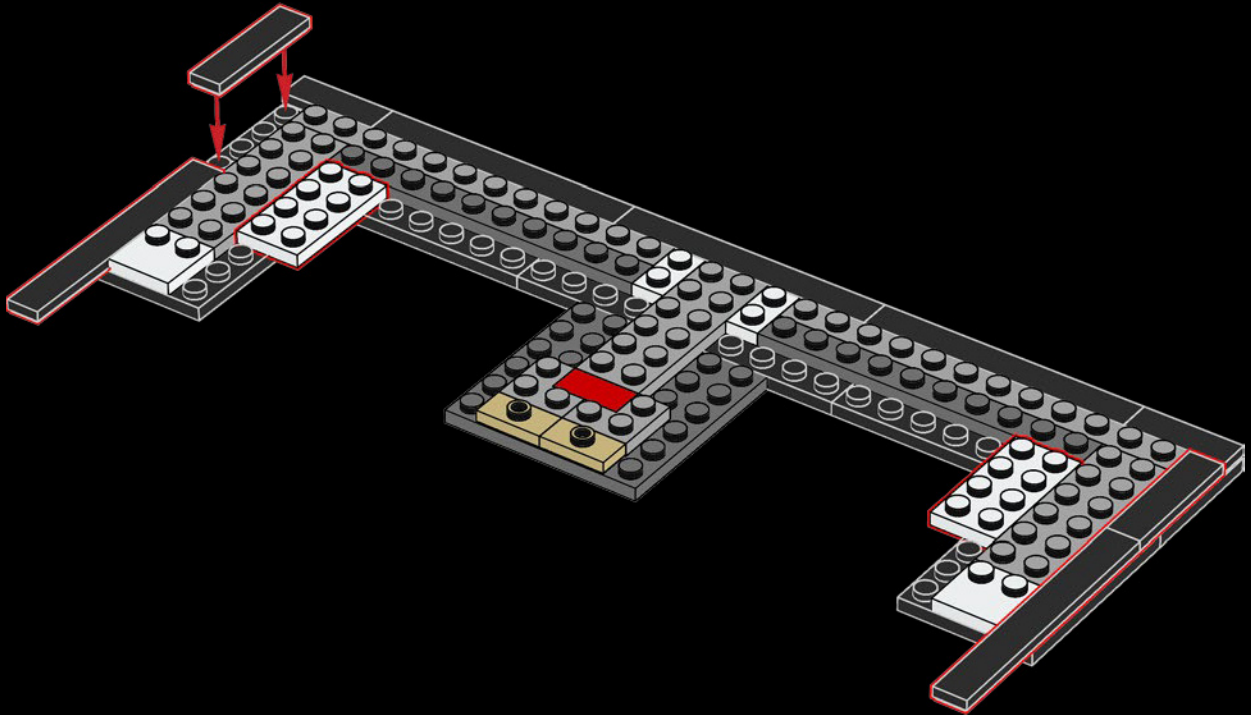

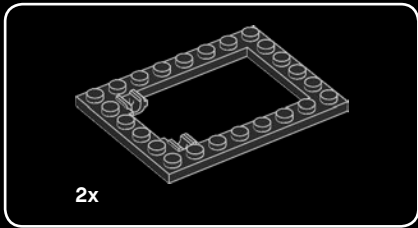

8

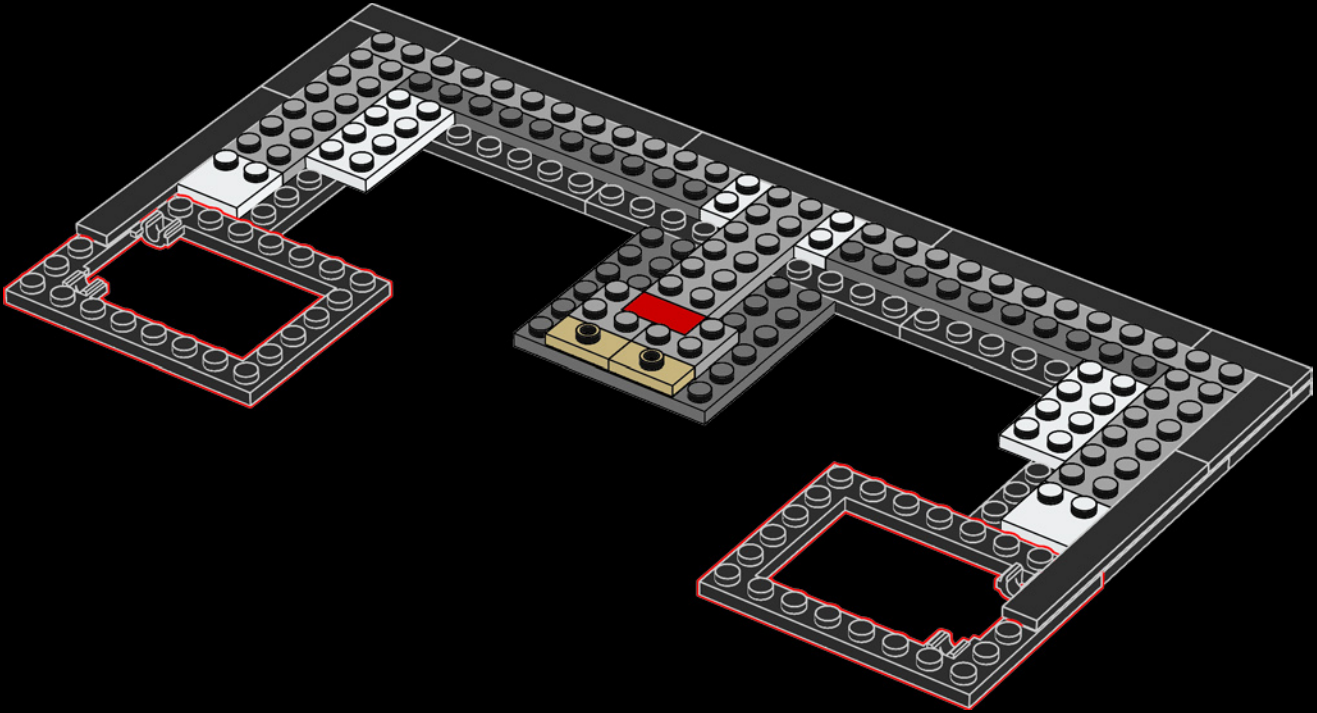



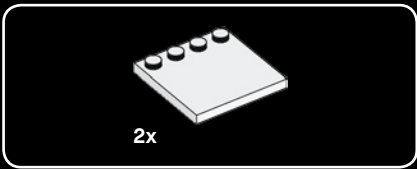

9

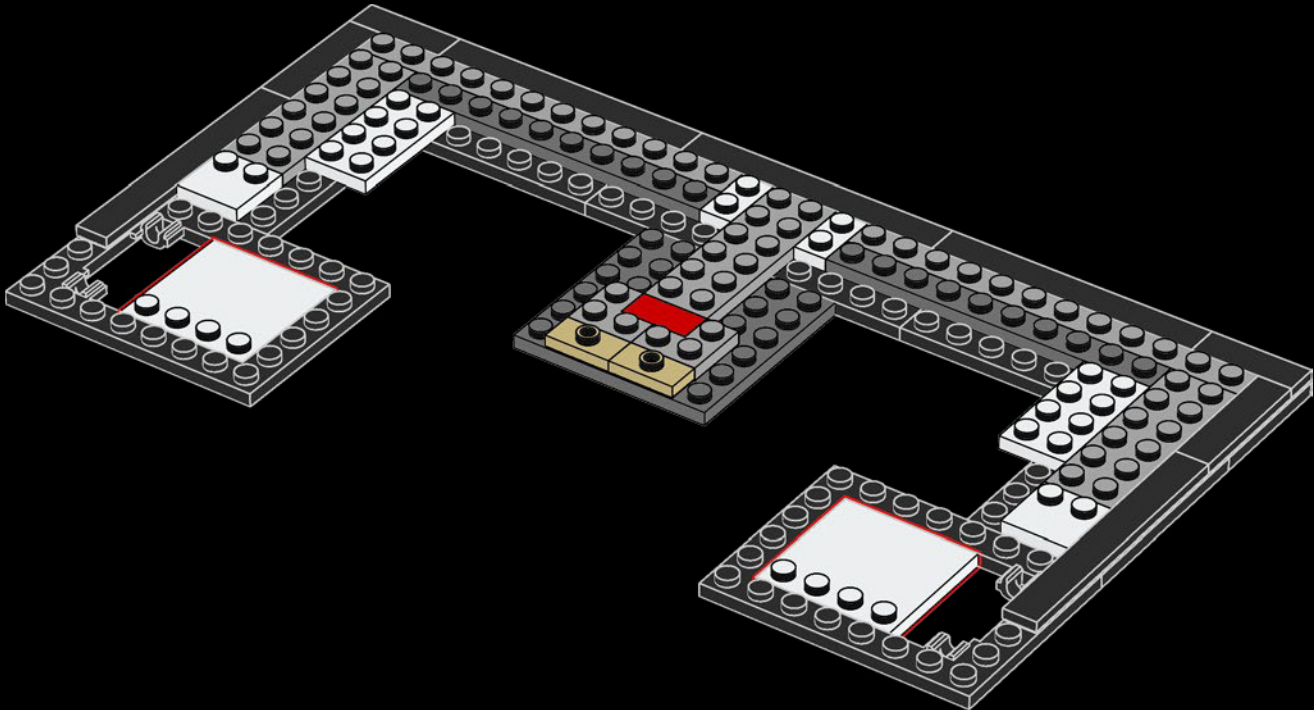

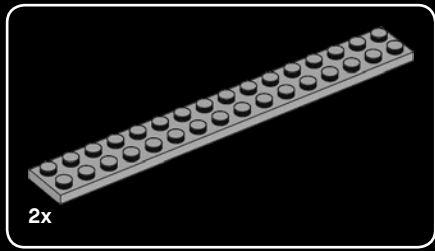

10

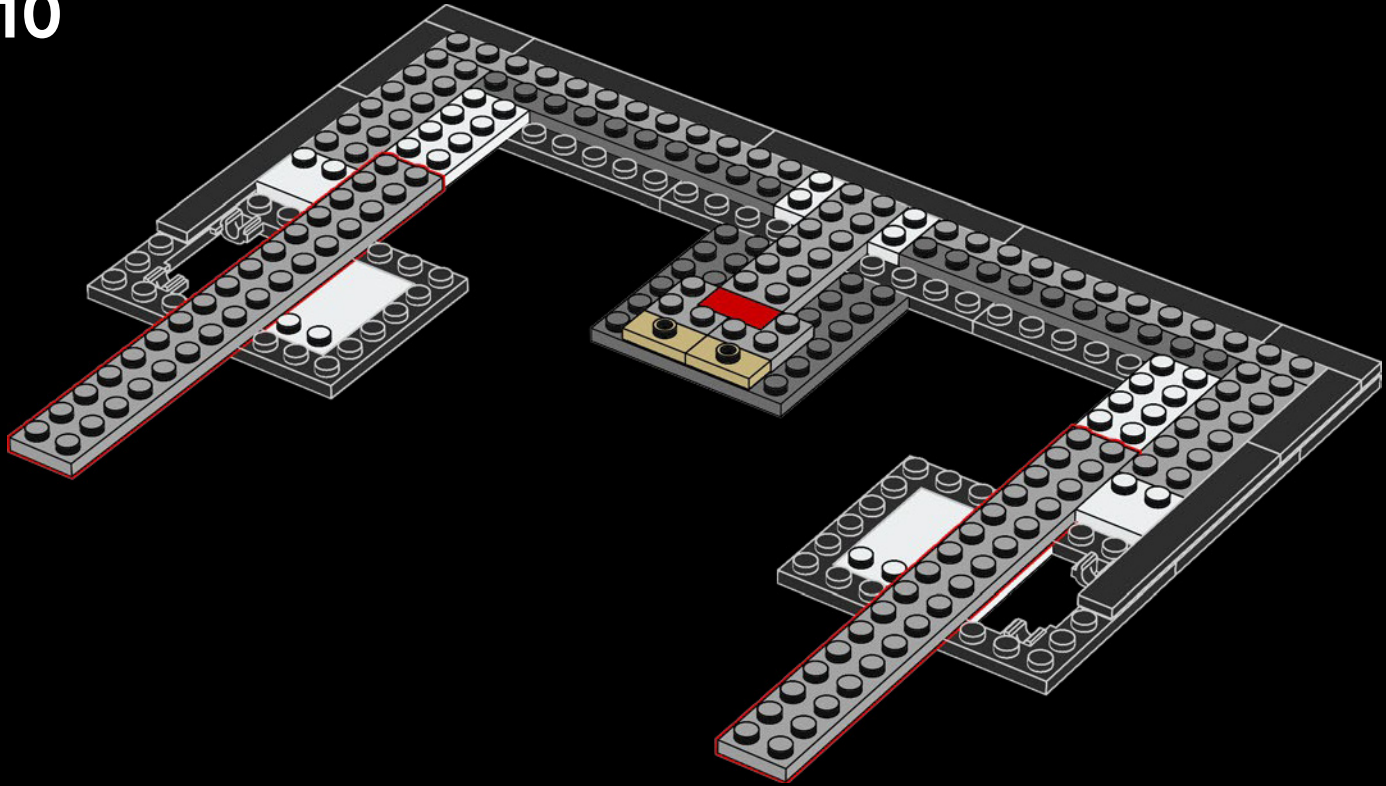

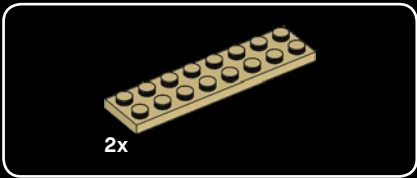

11

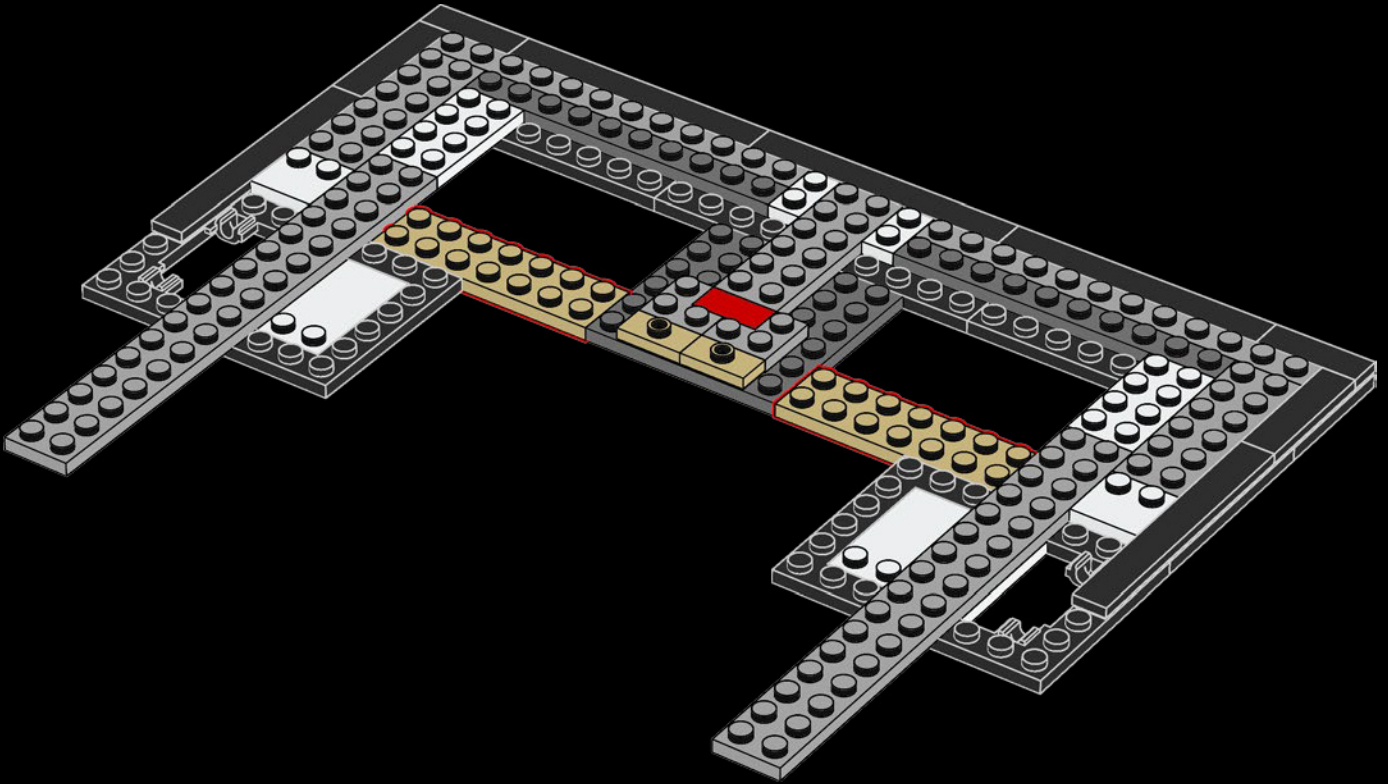

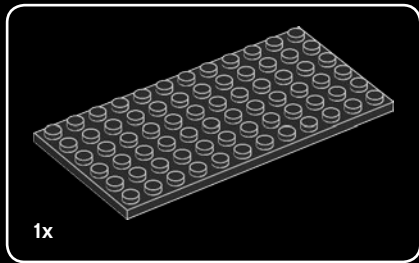

12

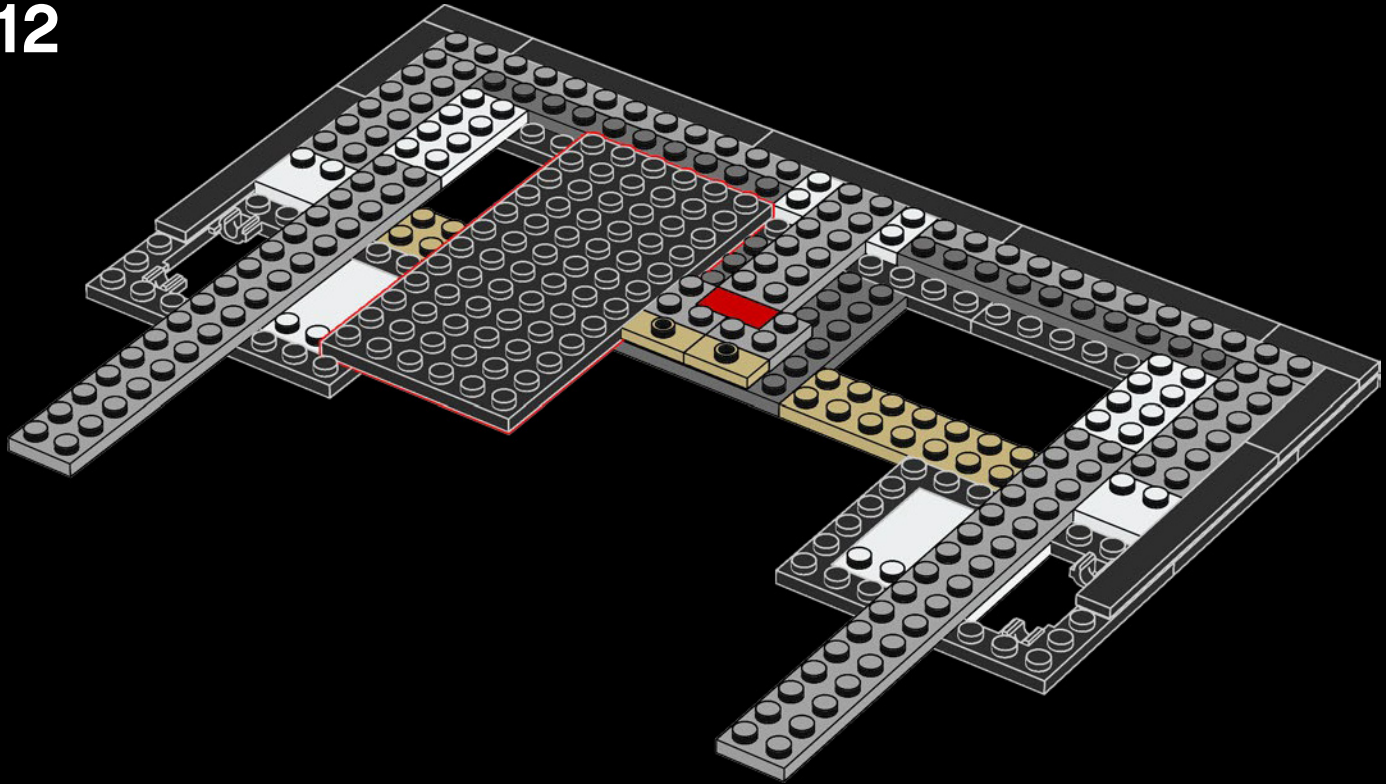



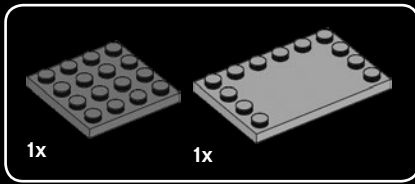

13

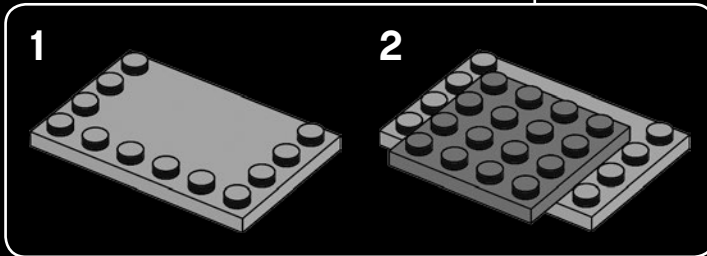
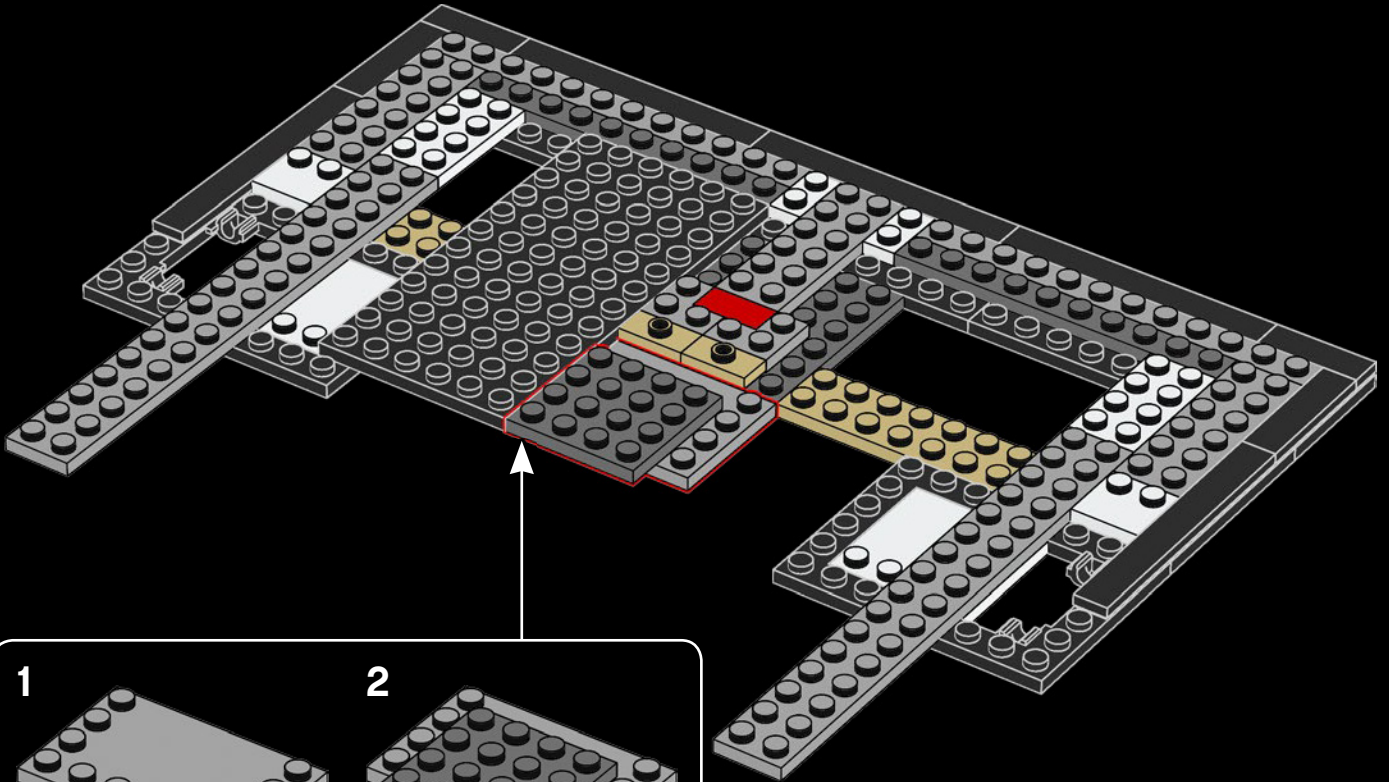

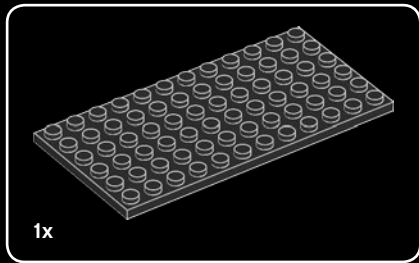

14

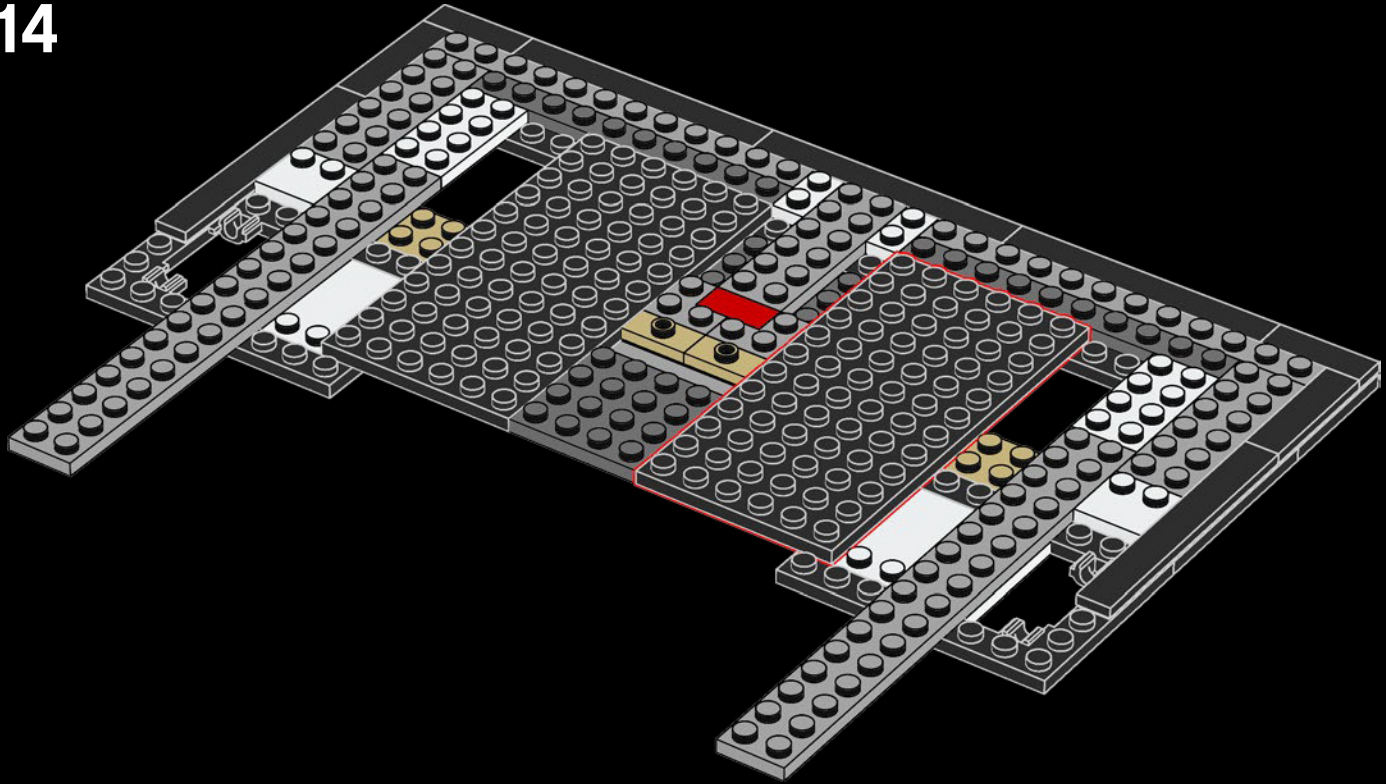



15

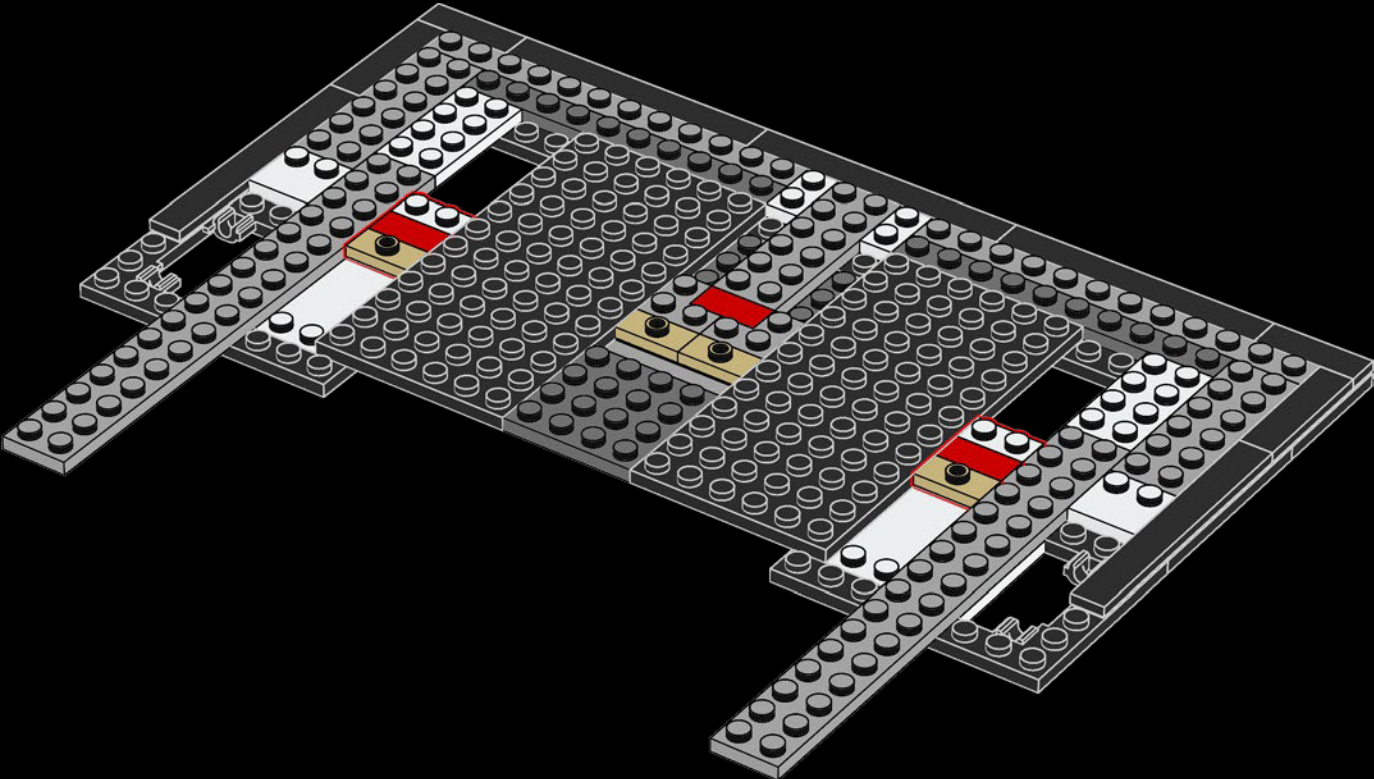

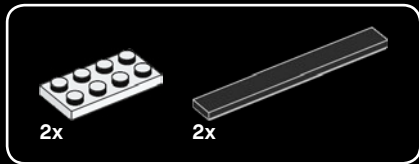

16

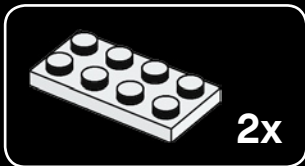
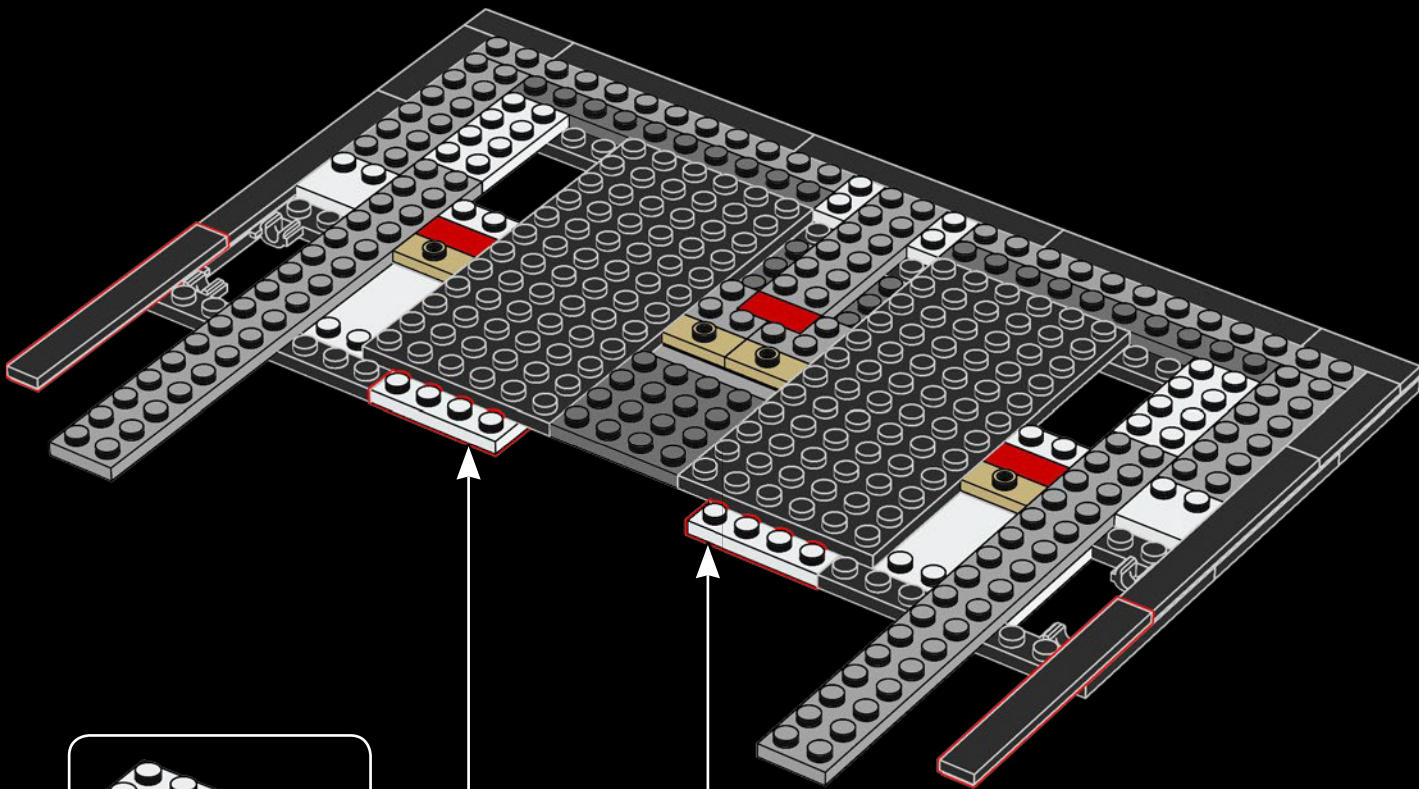



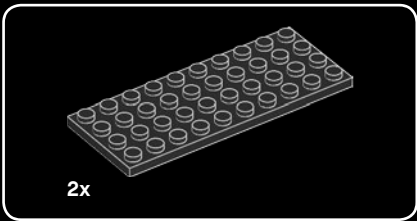

17

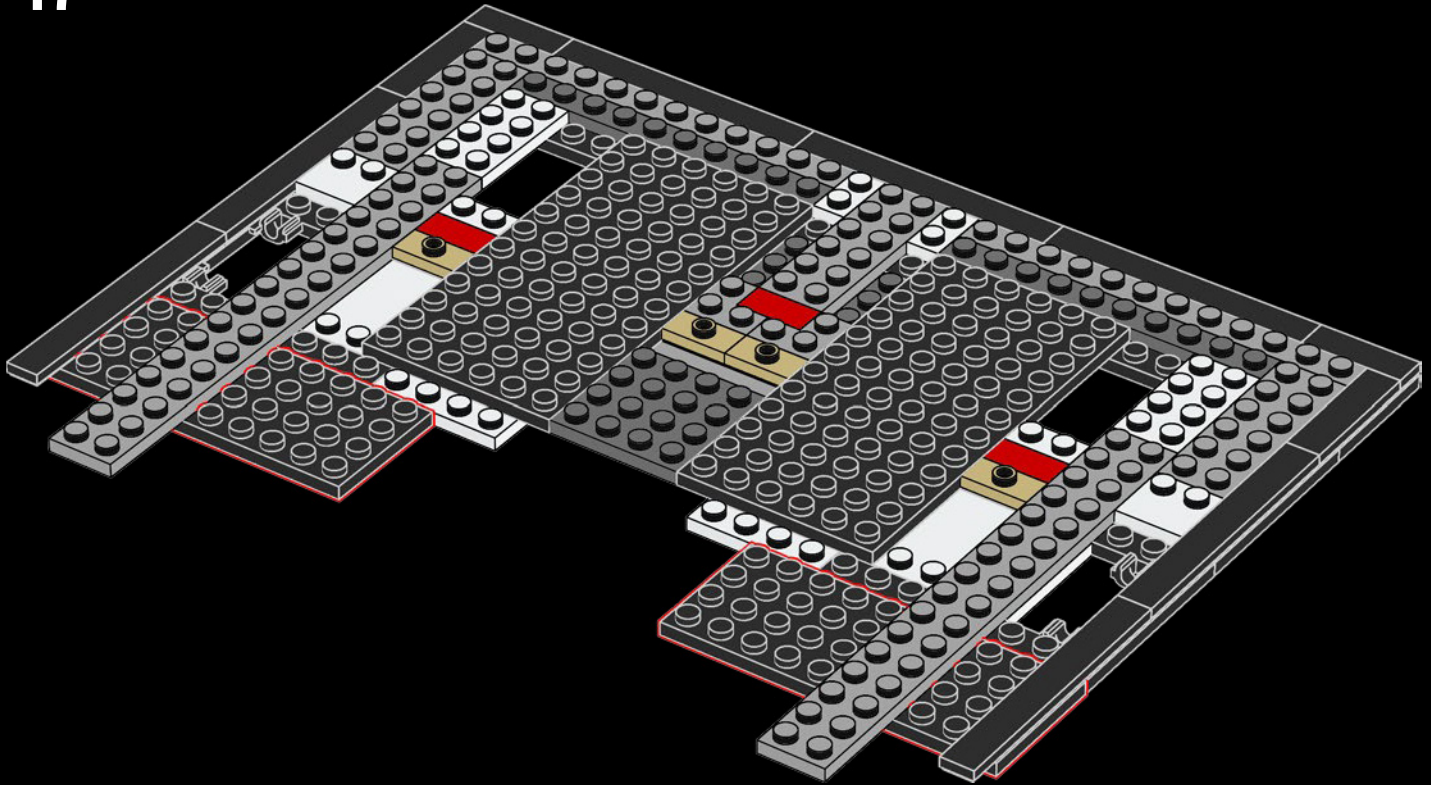

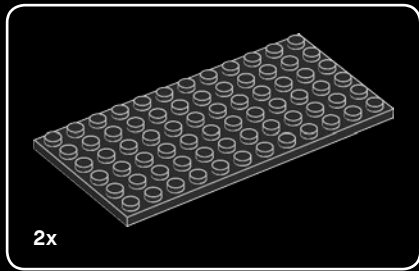

18

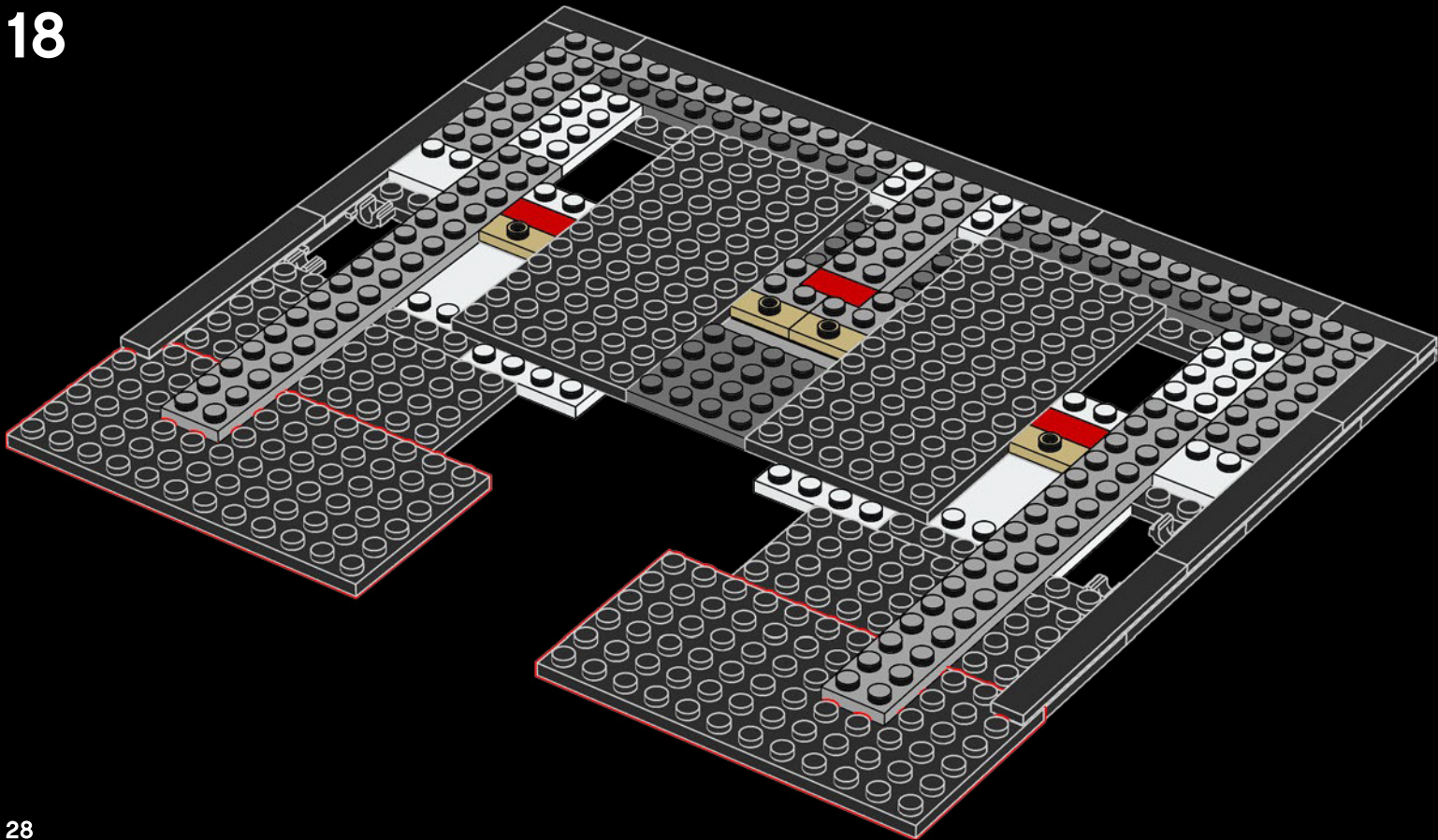

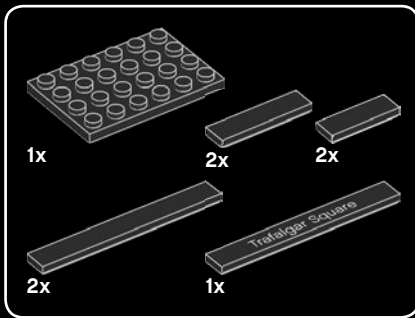

19

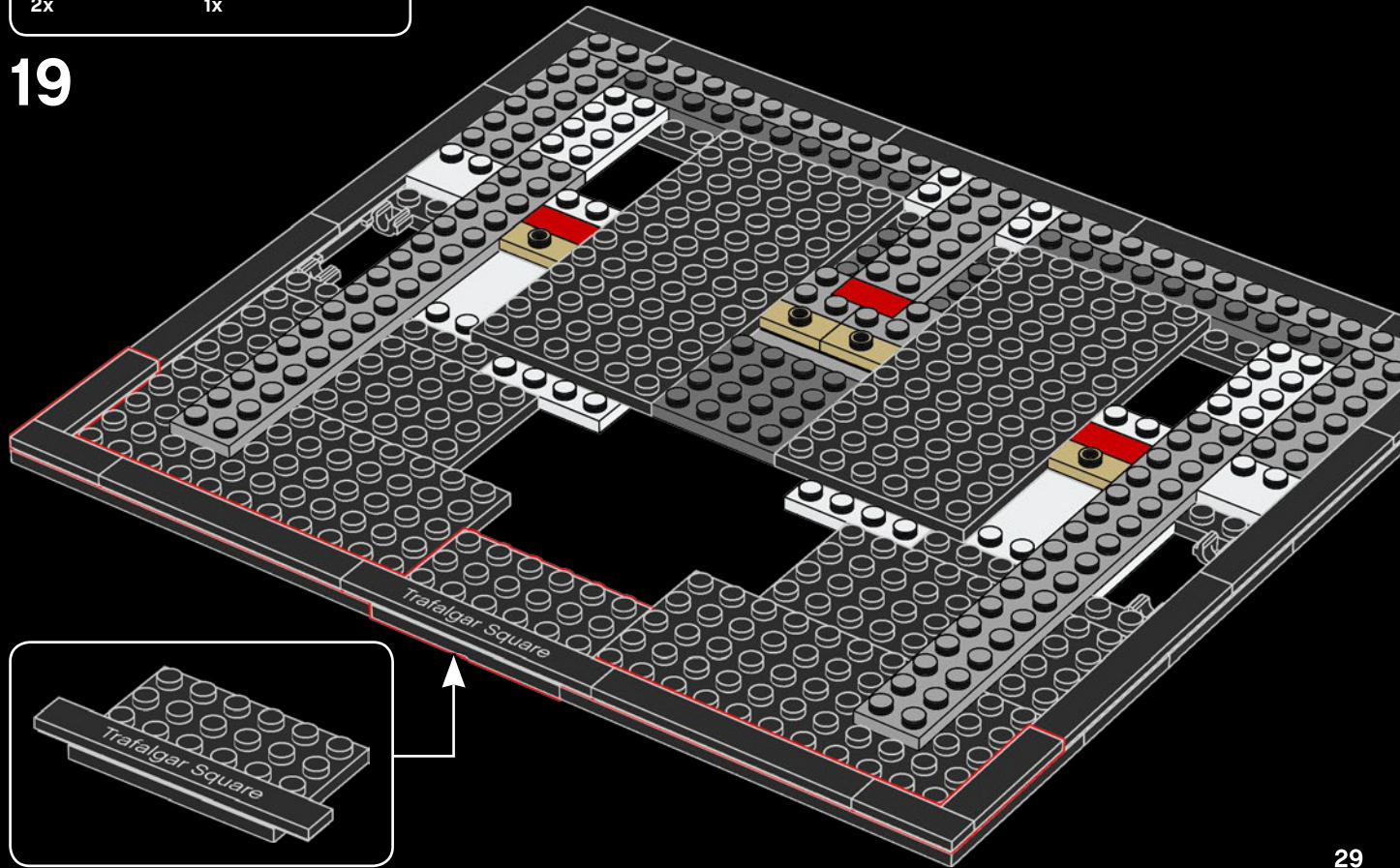



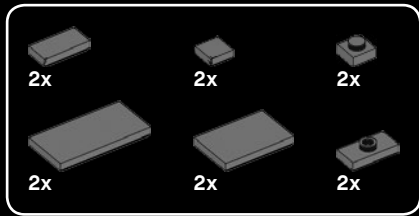

20

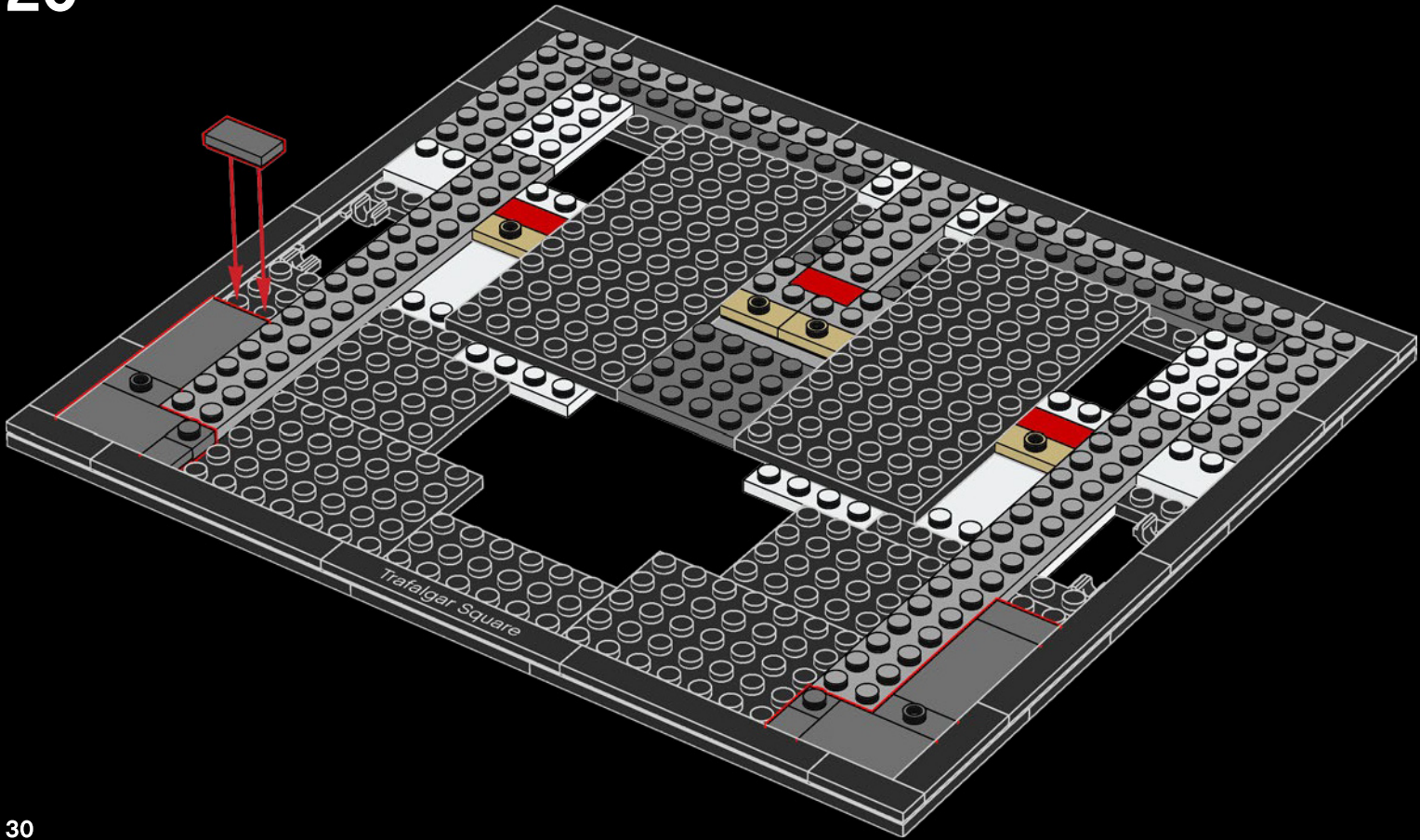

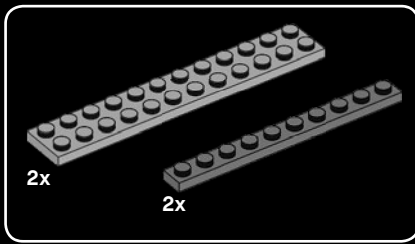

21

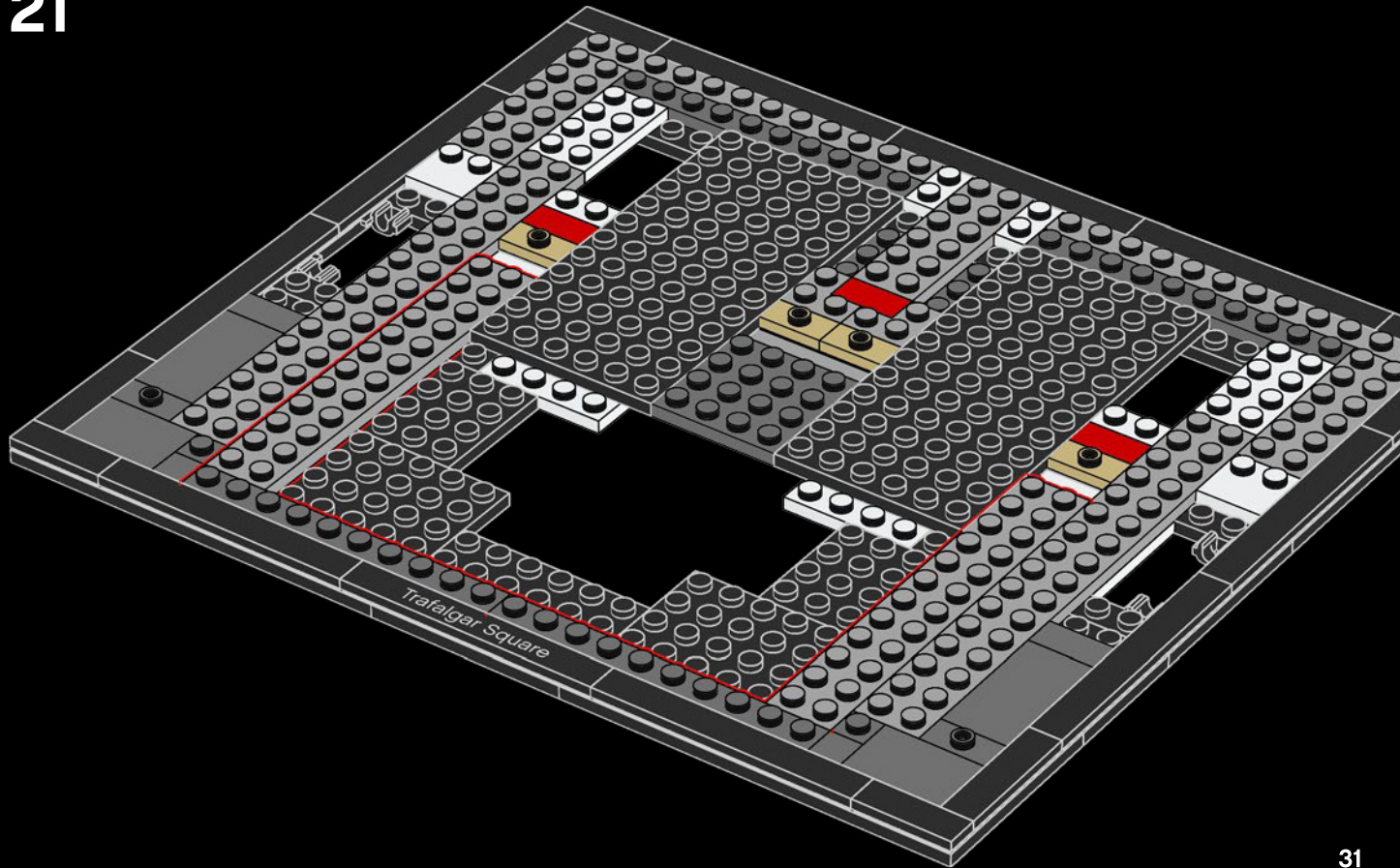



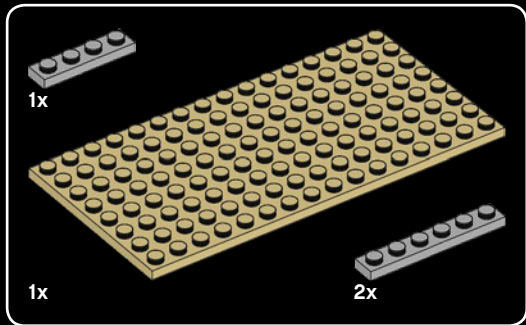

22

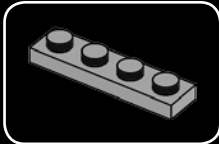
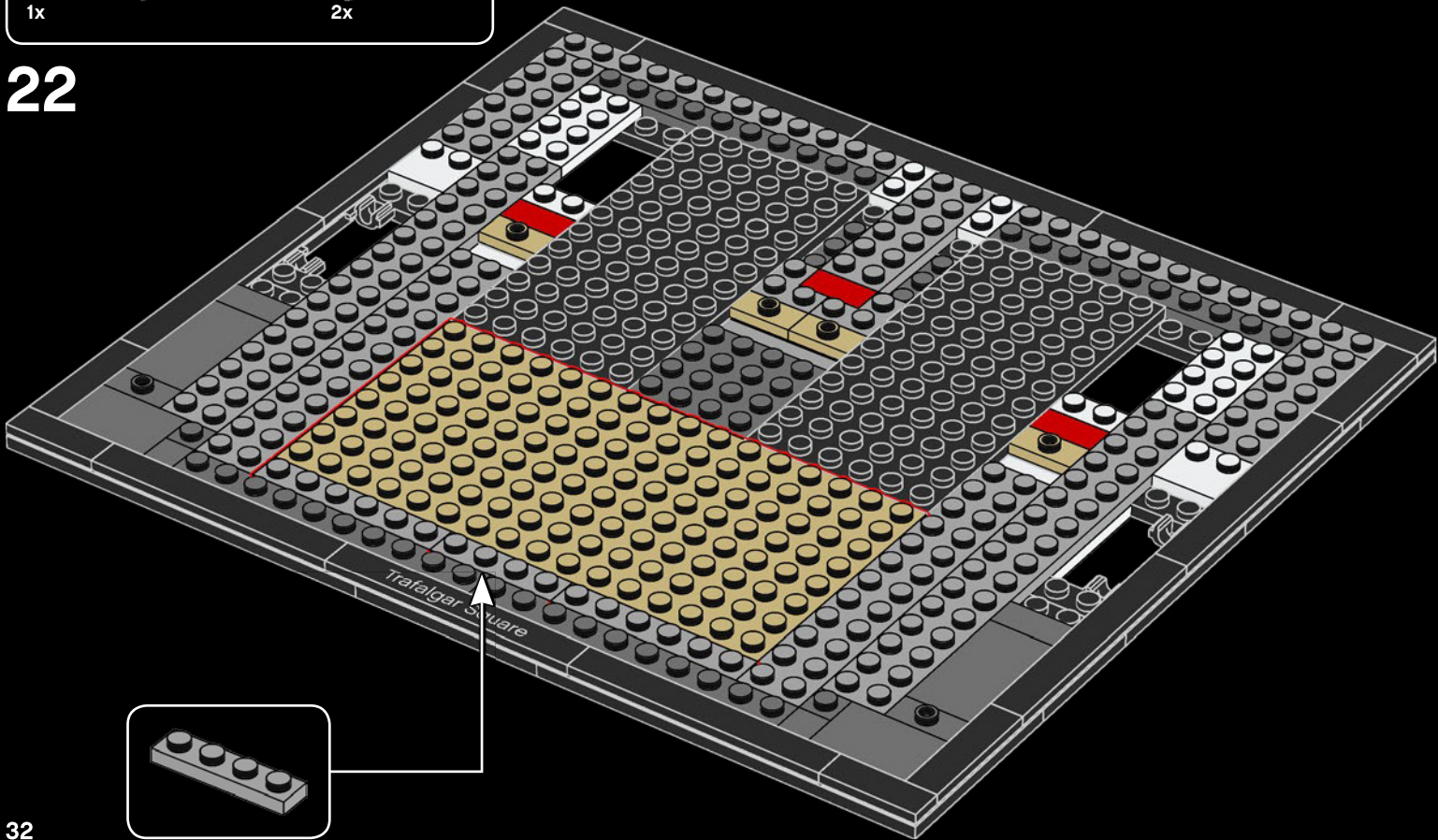

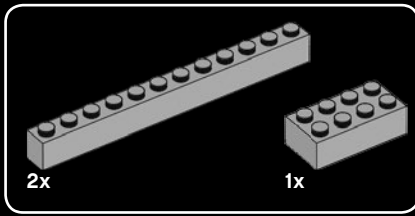

23

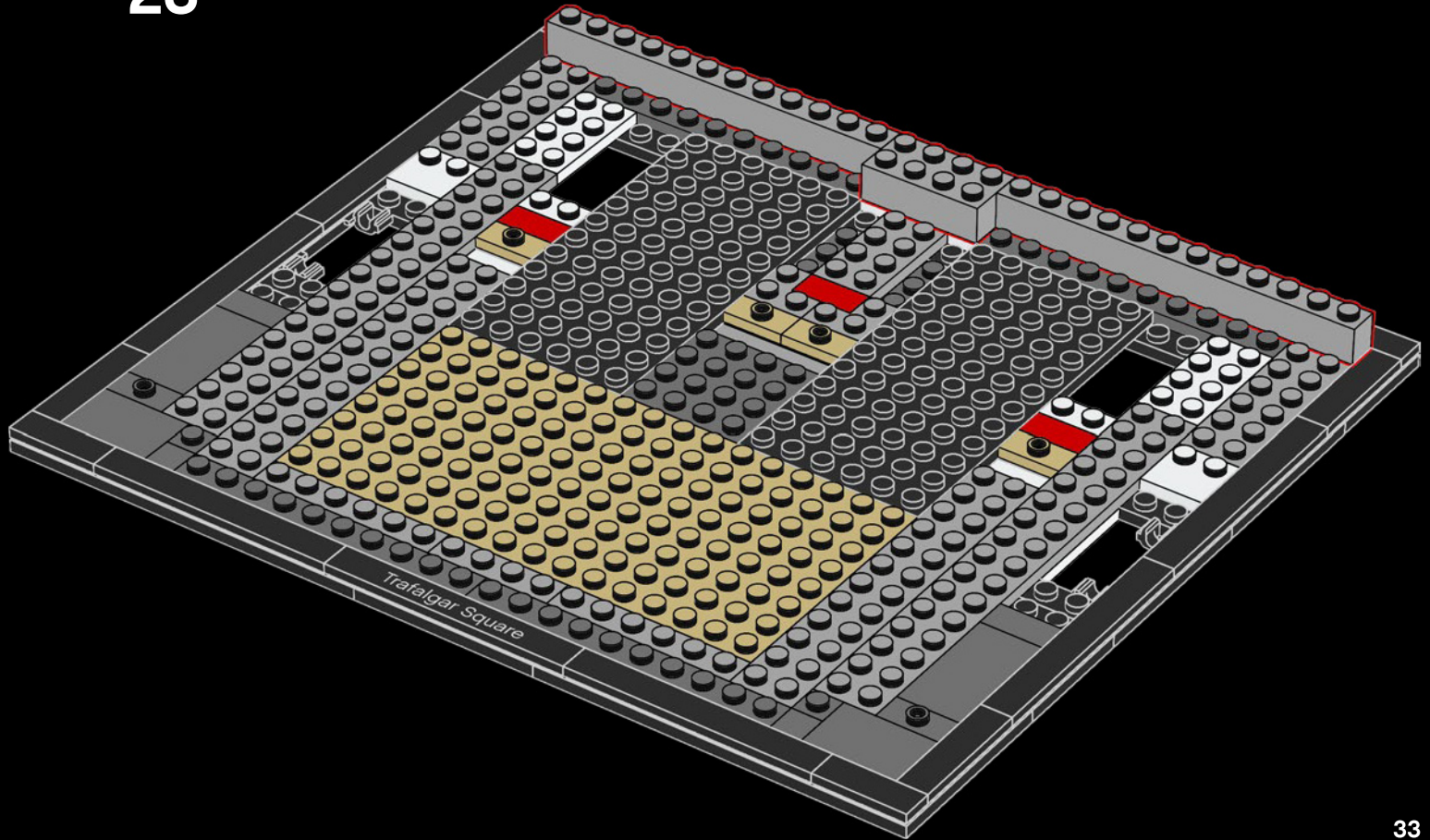



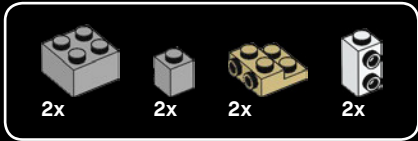

24

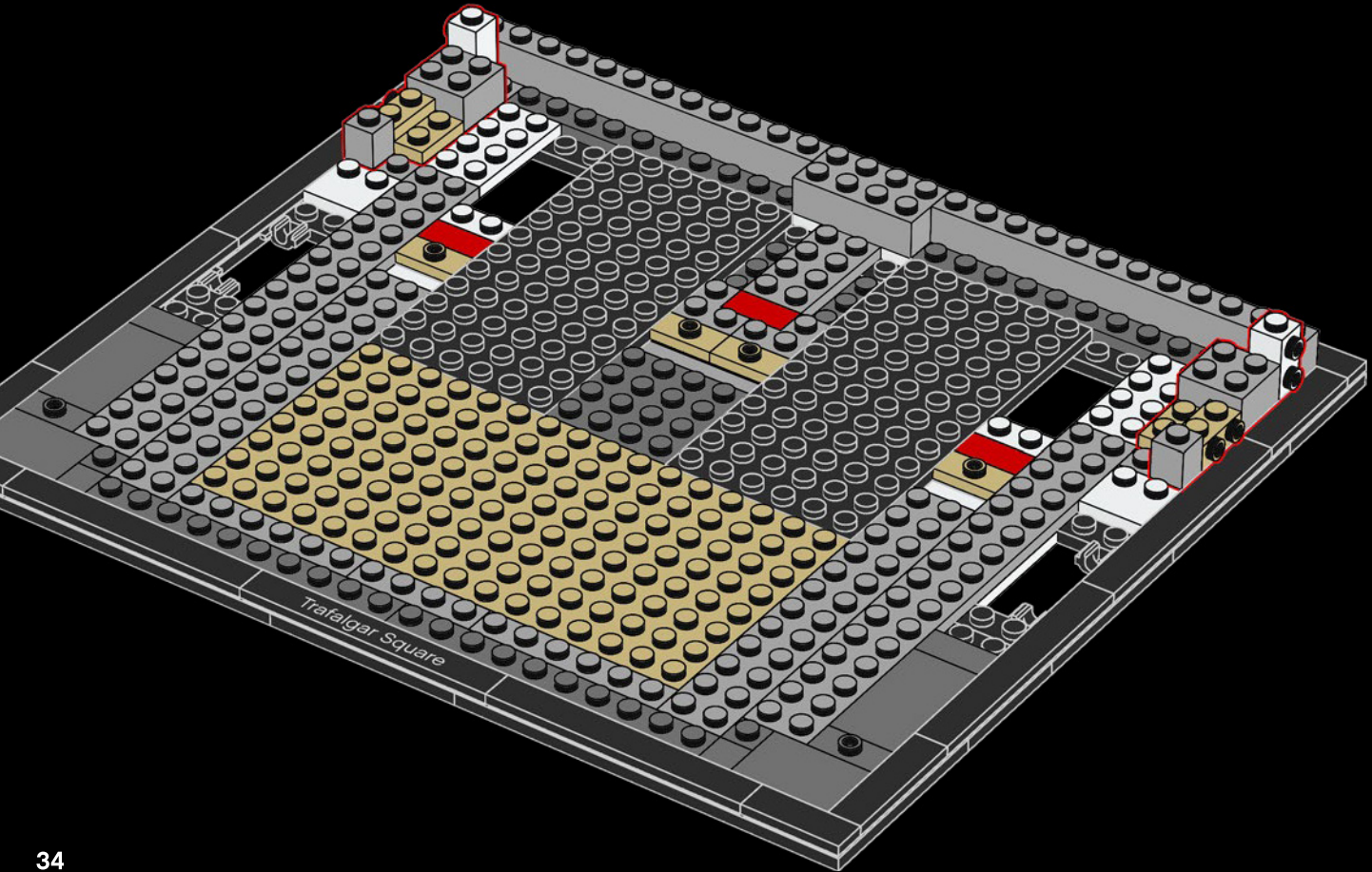

4x  2x 

25

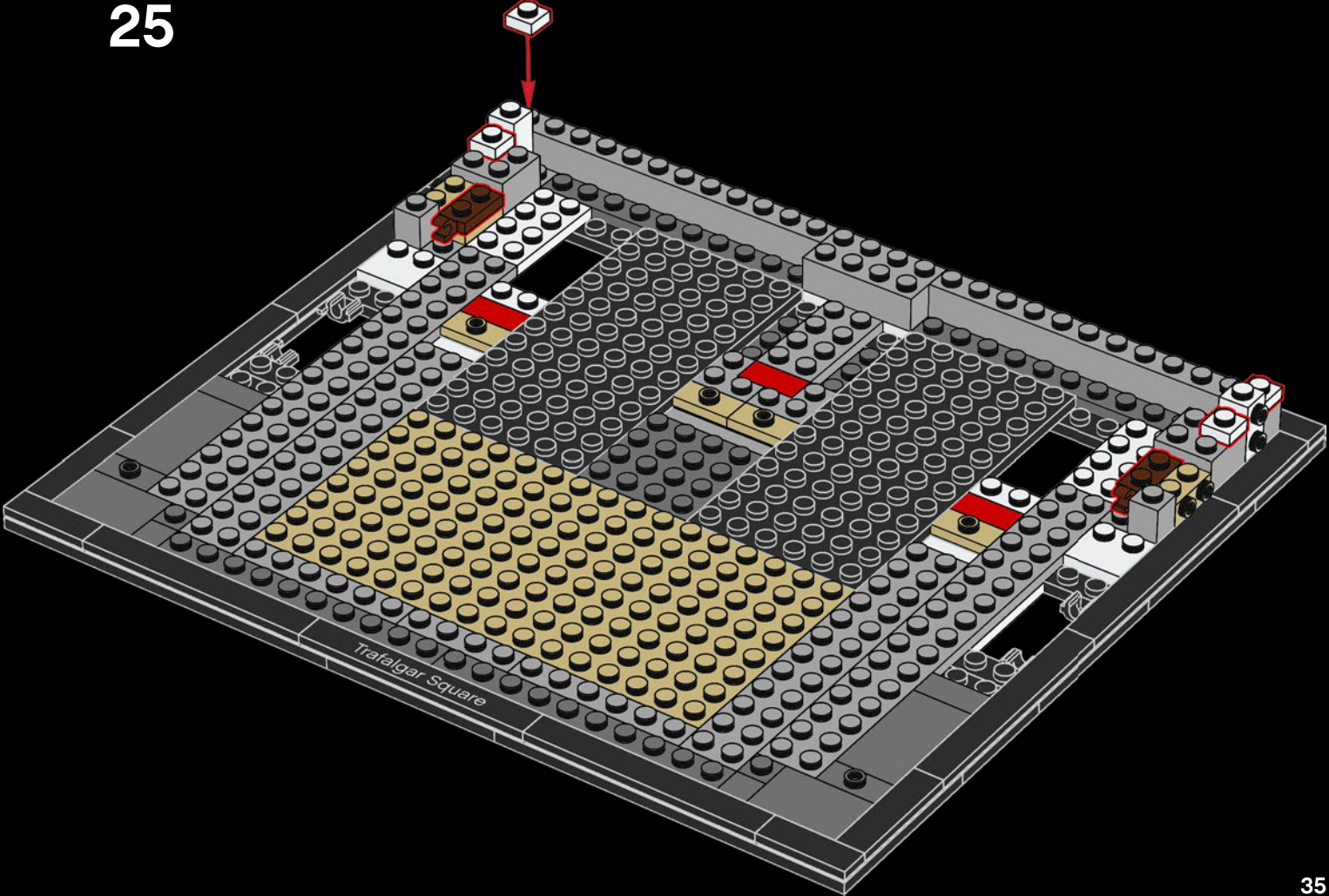

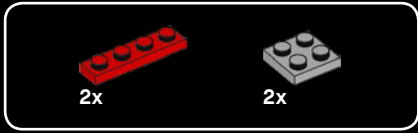

26

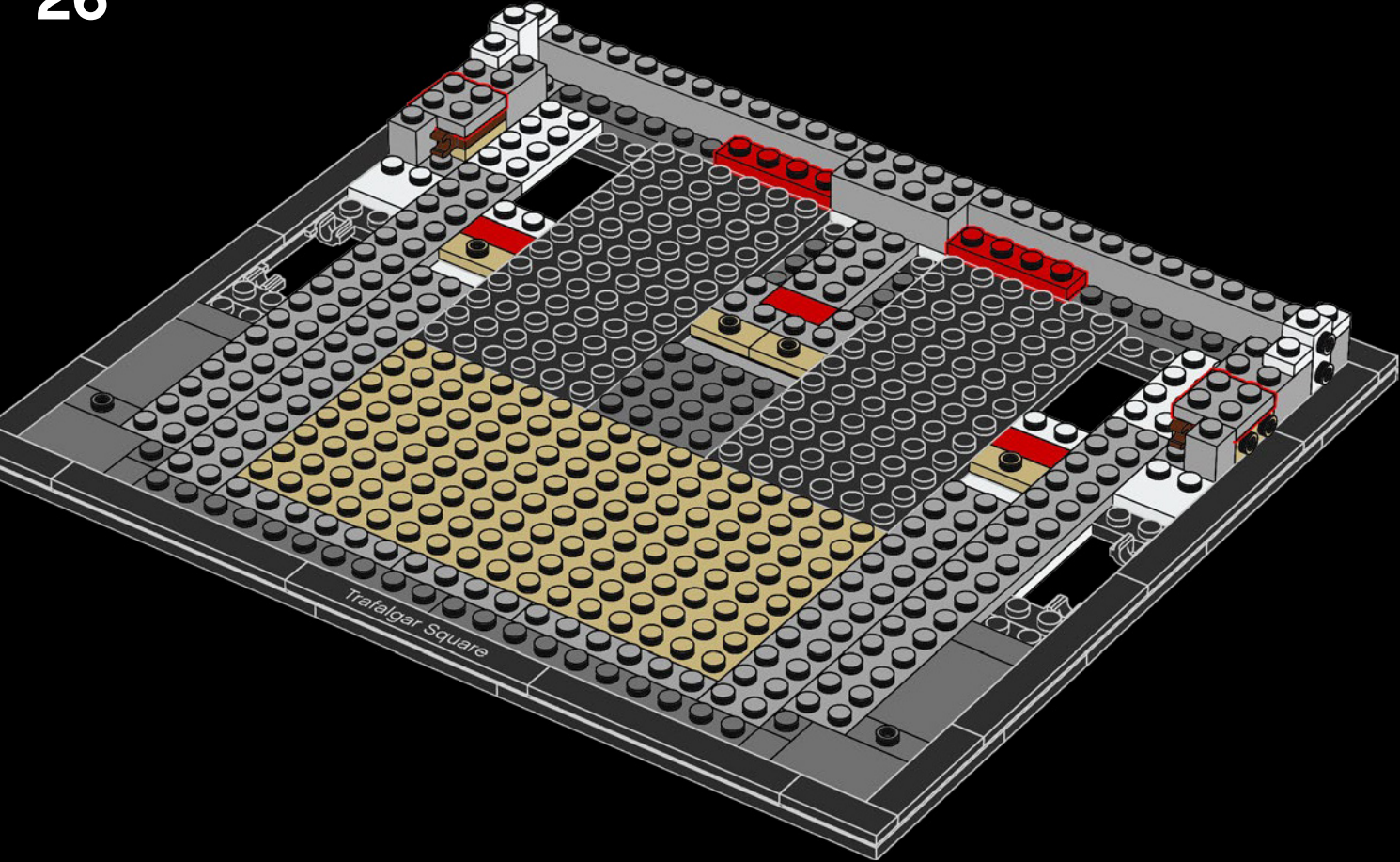



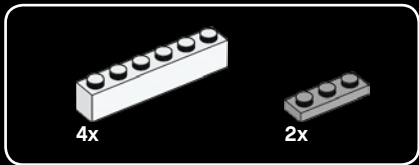

27

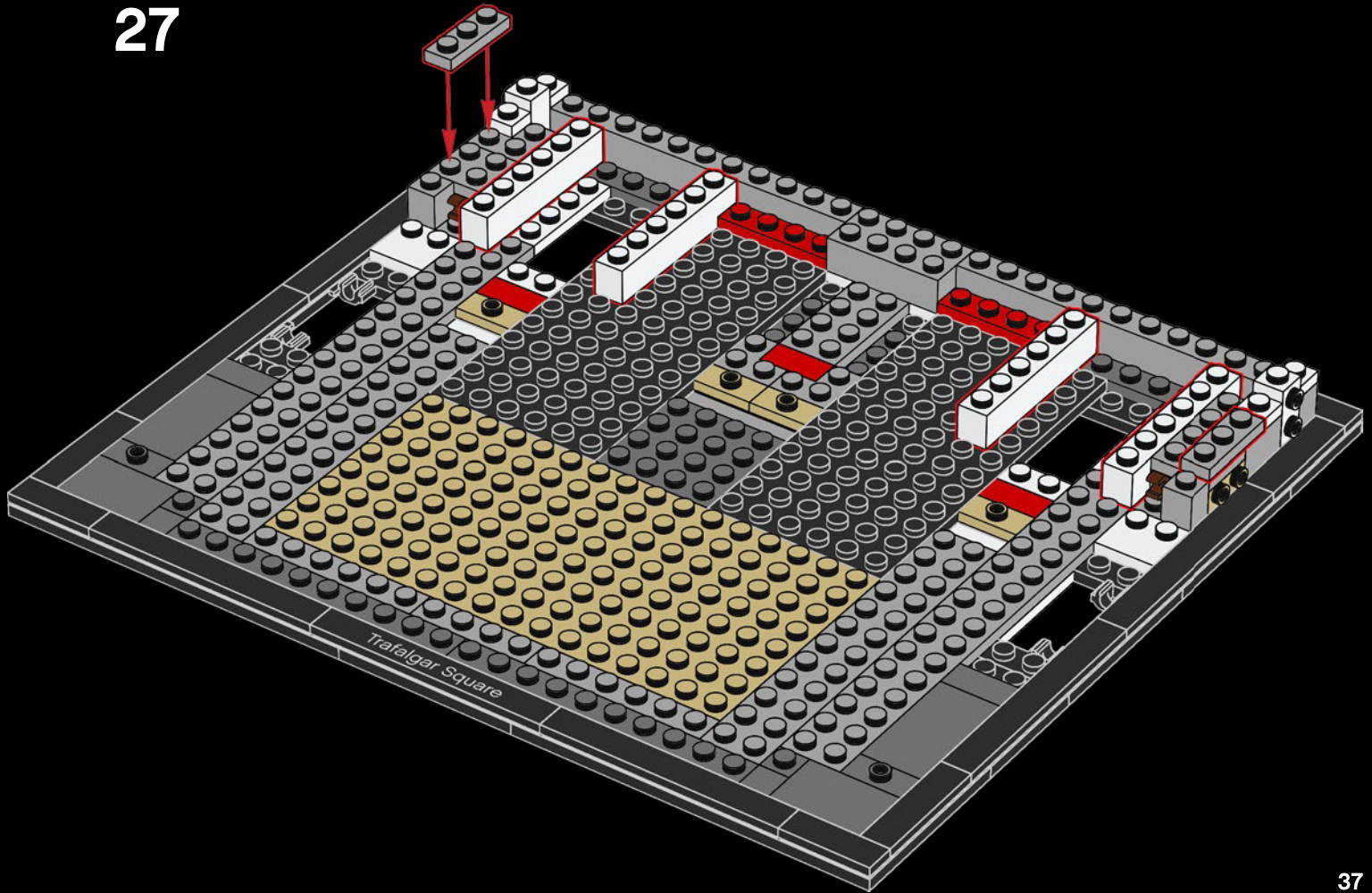

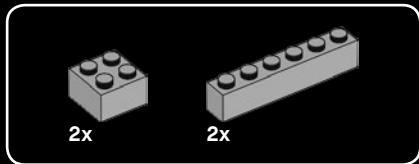

28

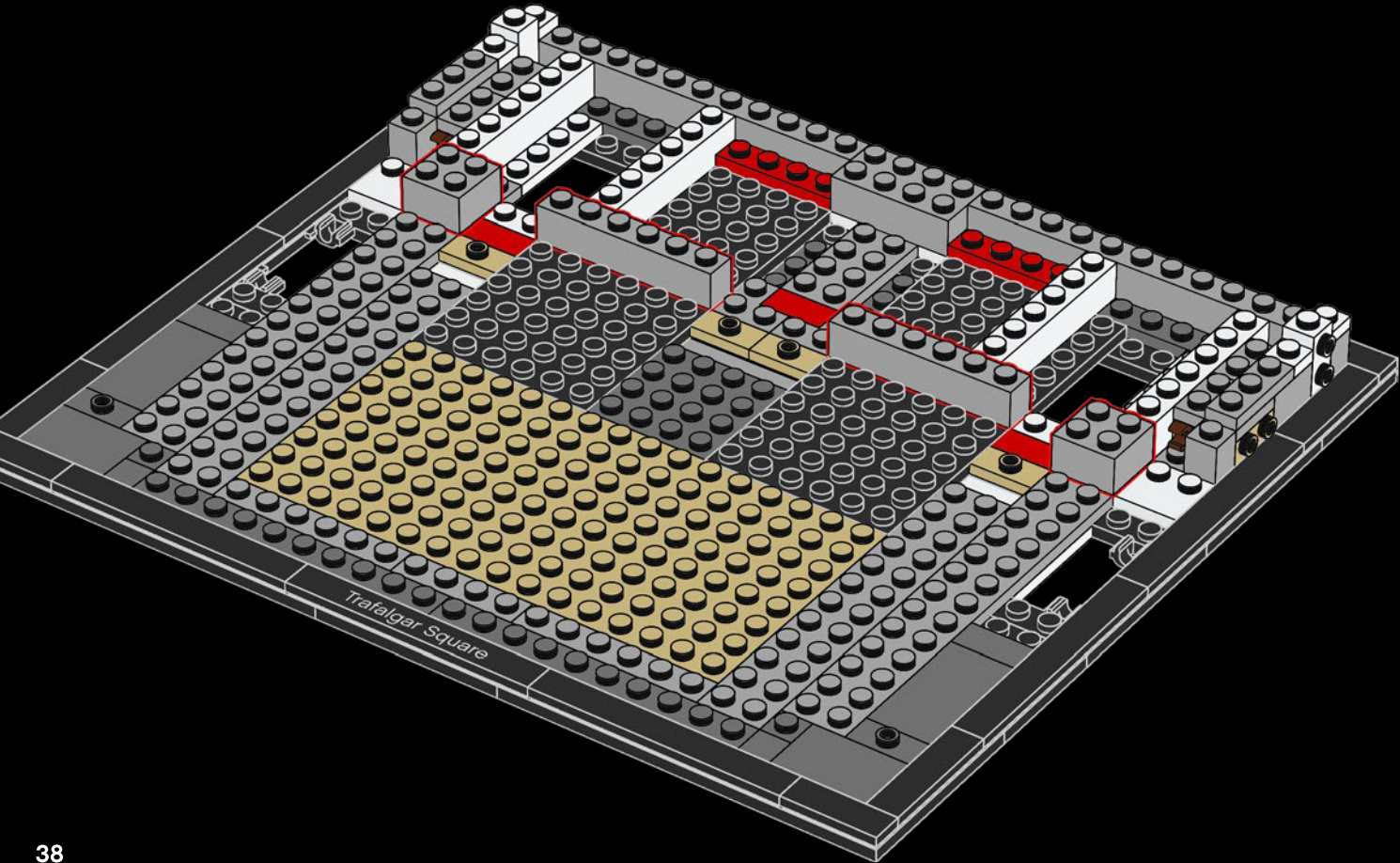



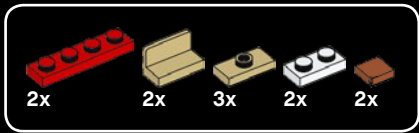

29

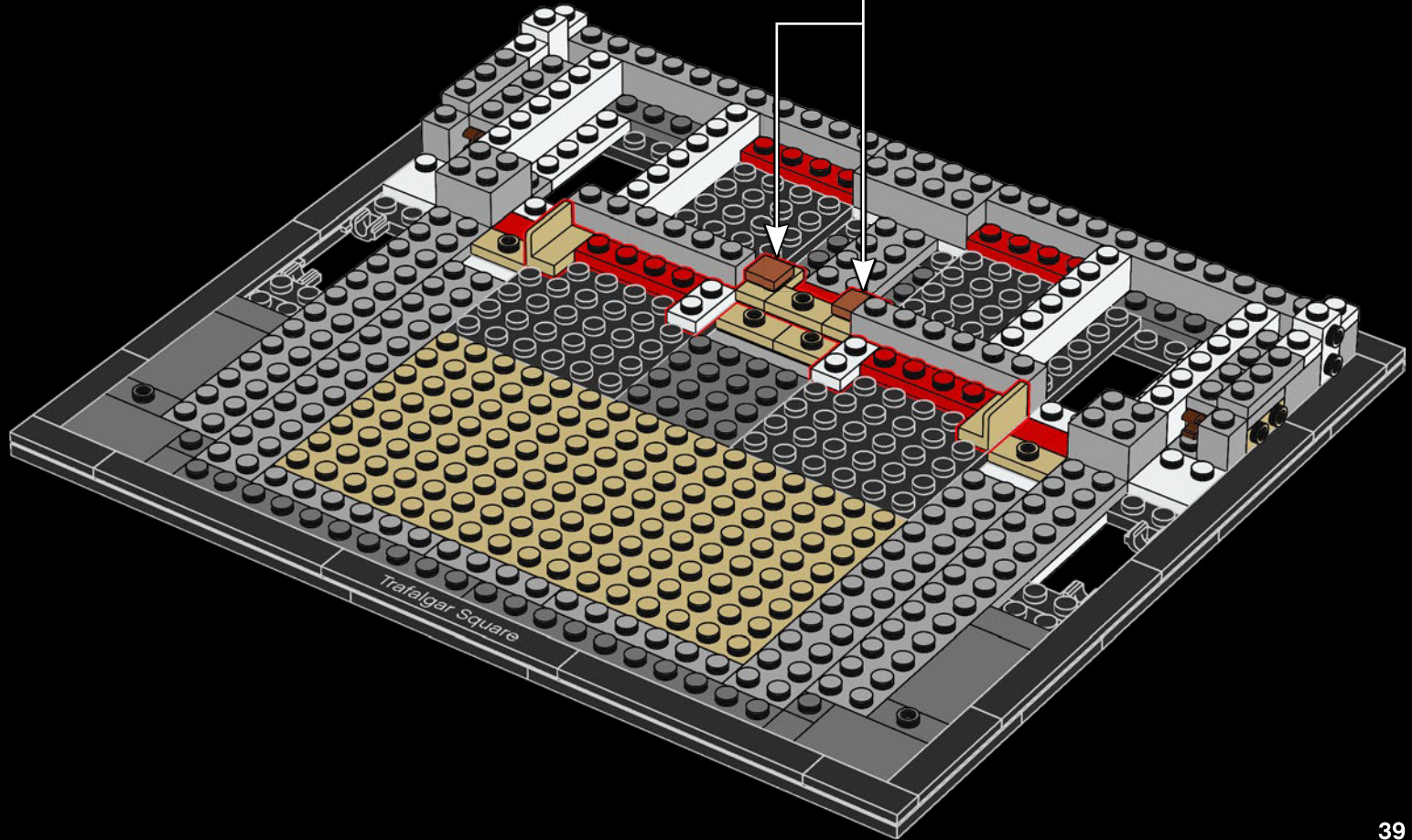
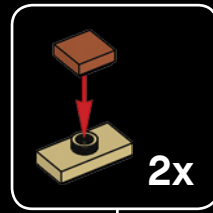

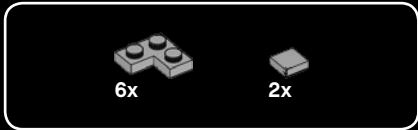

30

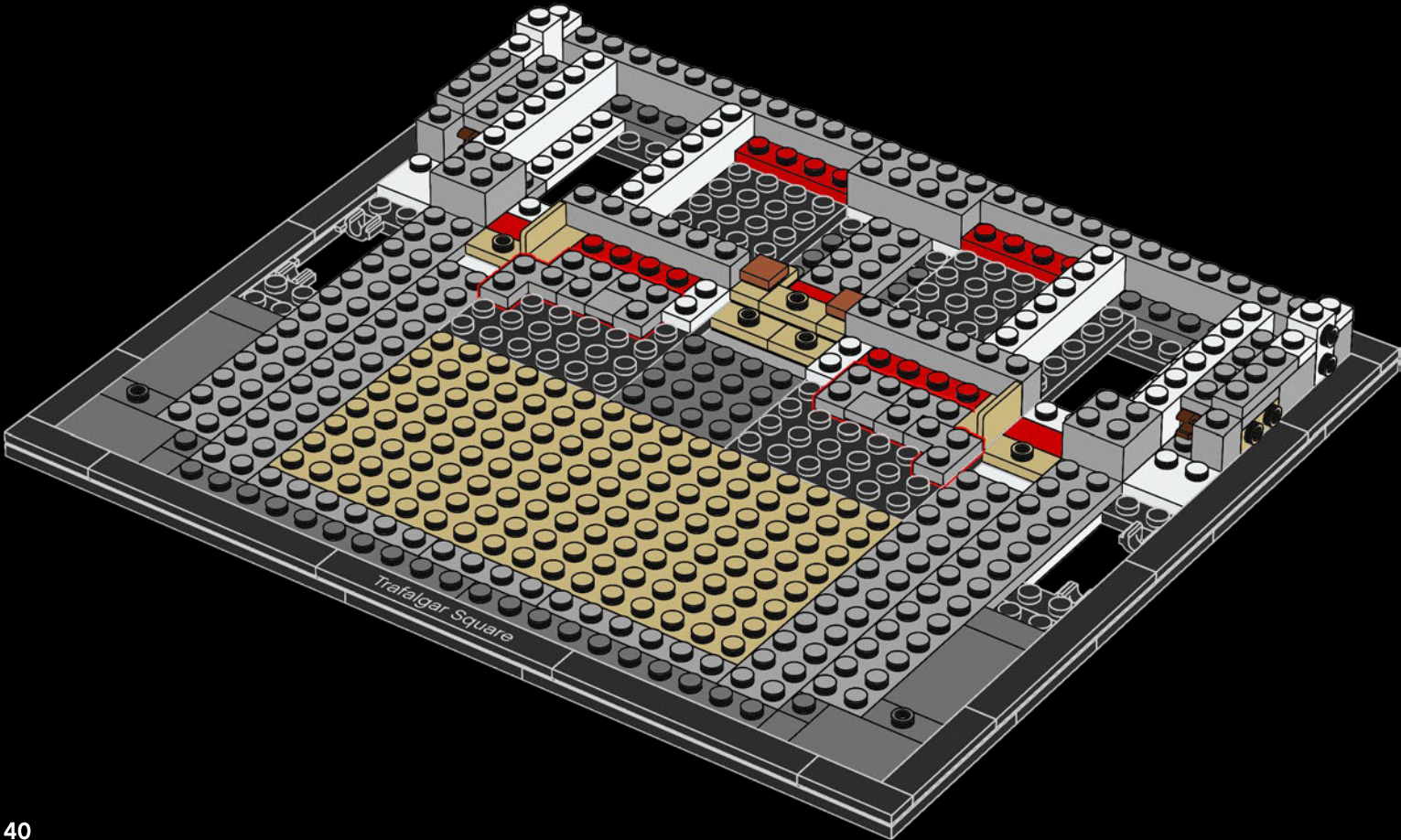

40



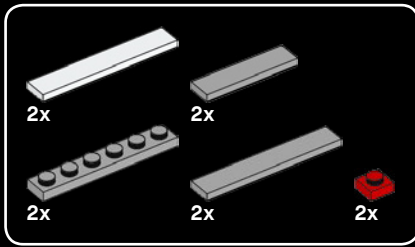

31

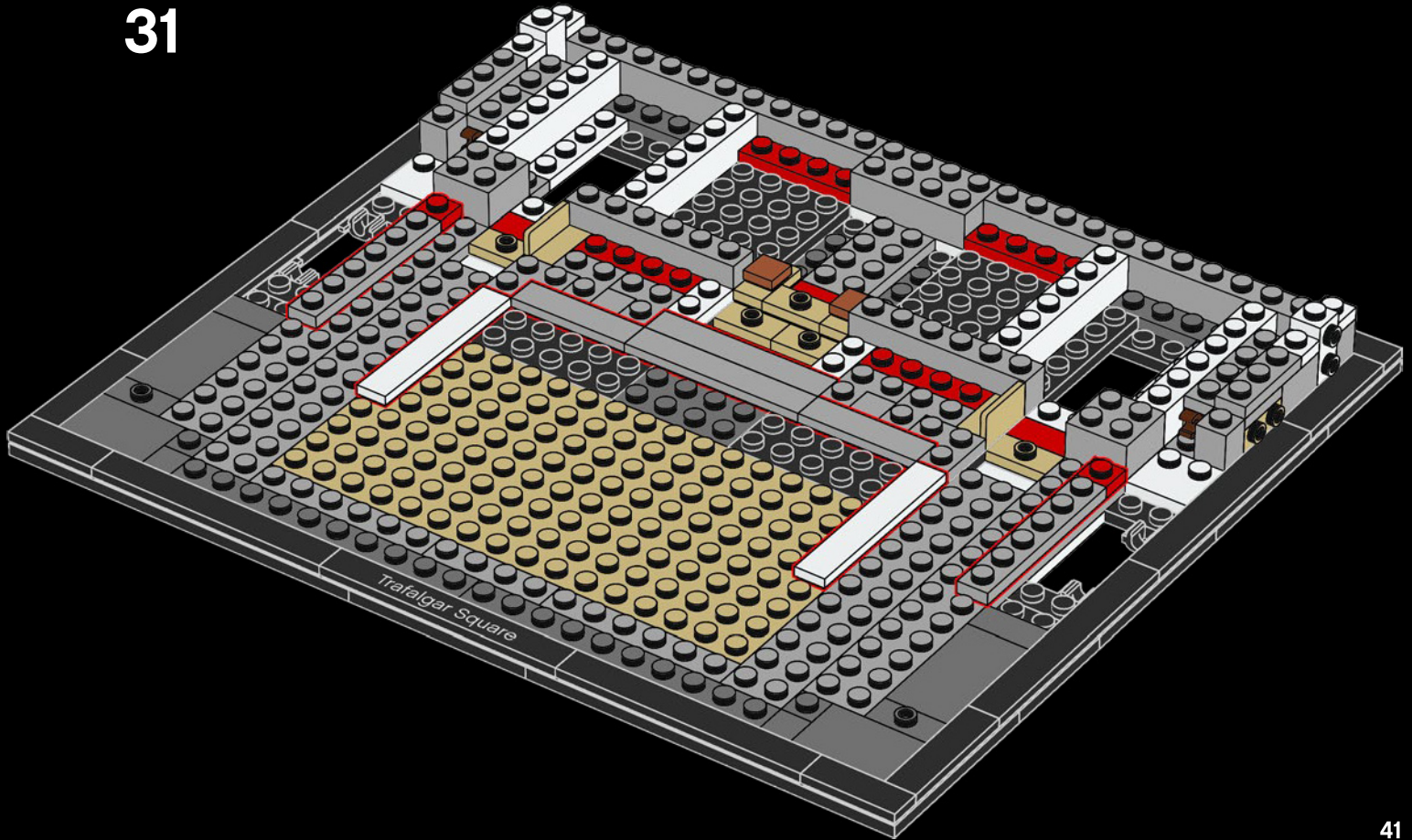





32

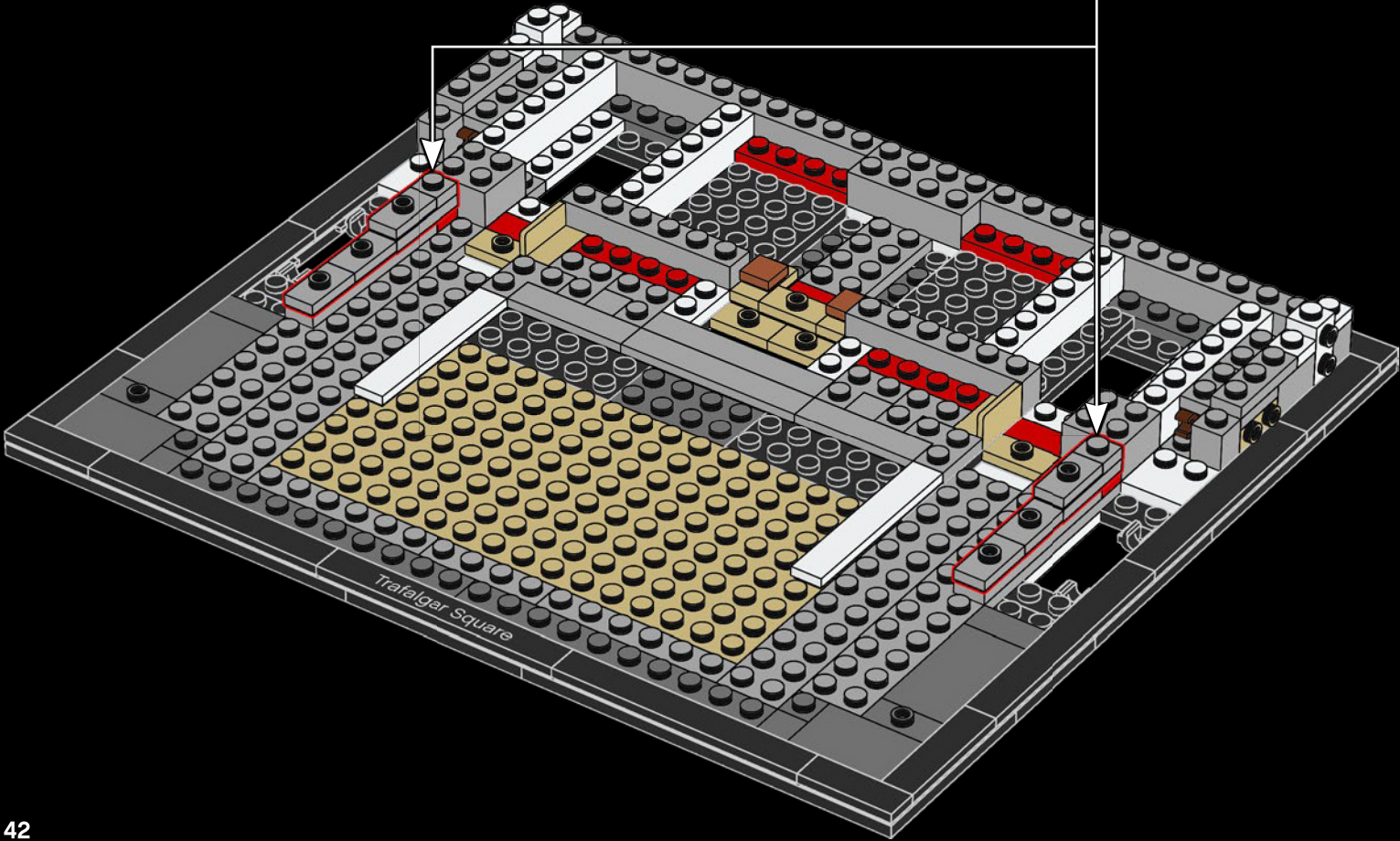
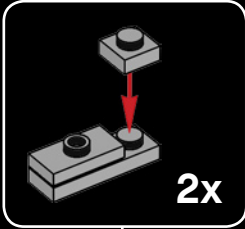

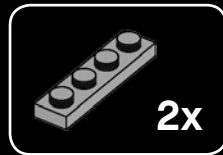
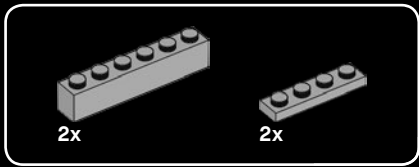

33

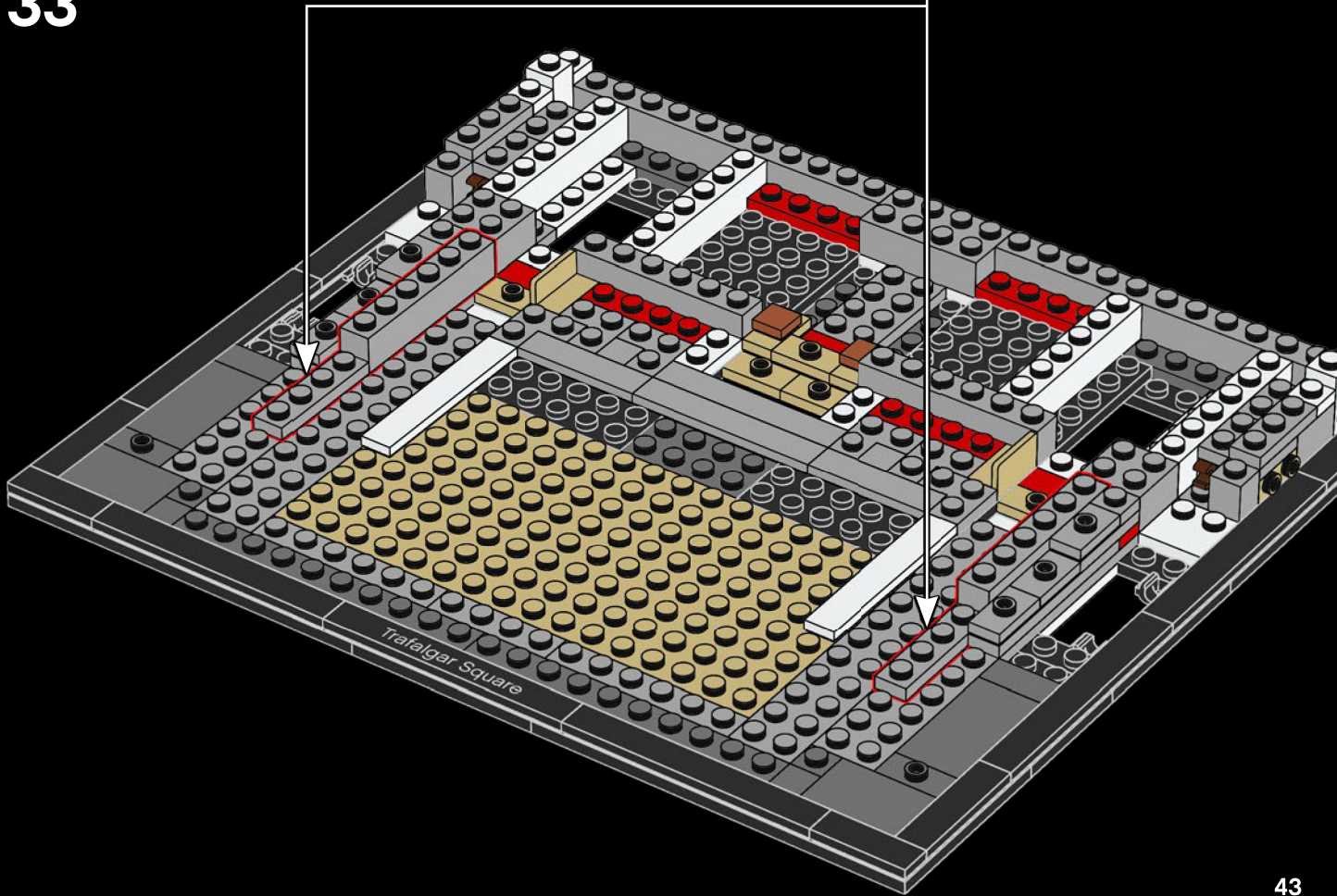



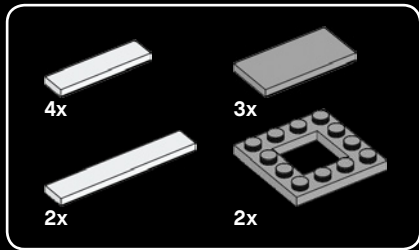

The square was known for the feral pigeons that would congregate in the space. That was until London Mayor Ken Livingstone banned the feeding of them and employed a hawk to keep them away.

La place était connue pour les pigeons sauvages qui s'y rassemblaient. Ils ont toutefois disparu lorsqu'un maire de Londres, Ken Livingstone, a émis l'interdiction de les nourrir et a utilisé un faucon pour les tenir éloignés.

La plaza era conocida por las palomas salvajes que se congregaban en ella. Así fue hasta que Ken Livingstone, alcalde de Londres, prohibió alimentarlas y recurrió a un halcón para mantenerlas alejadas.

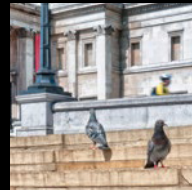

34

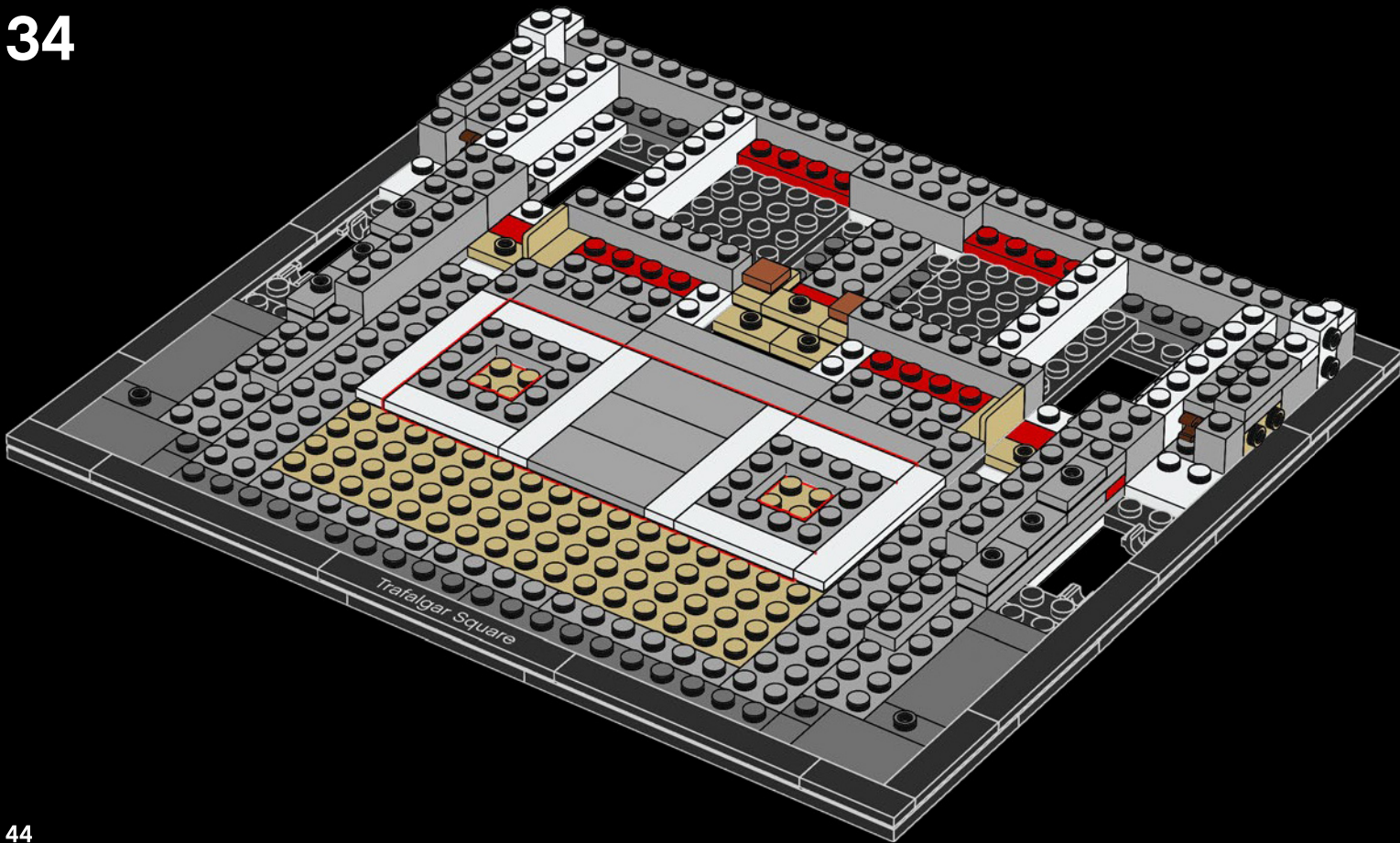

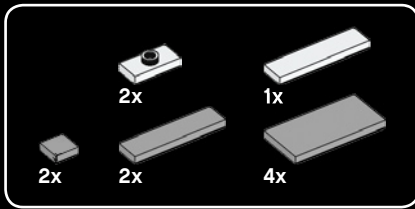

35

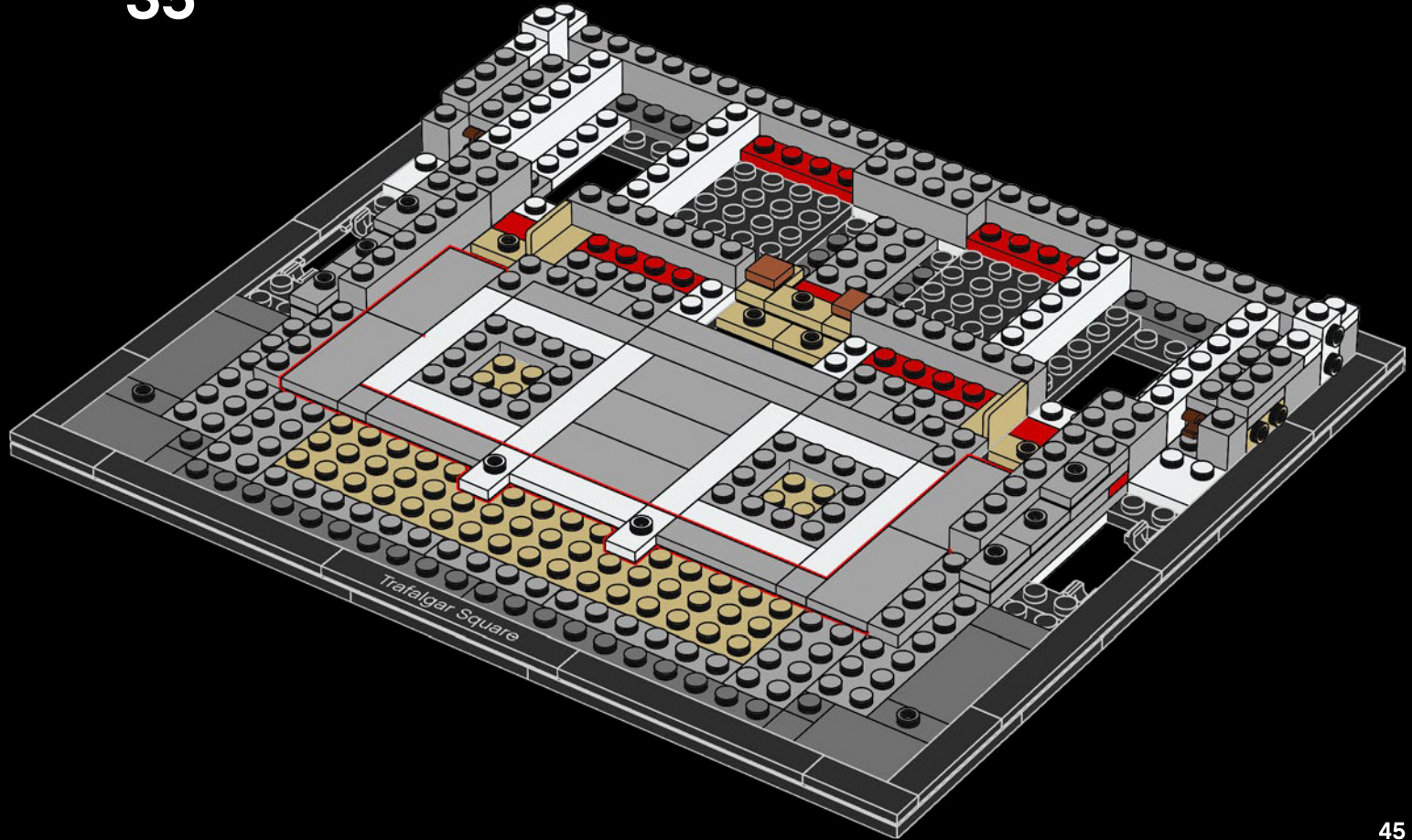



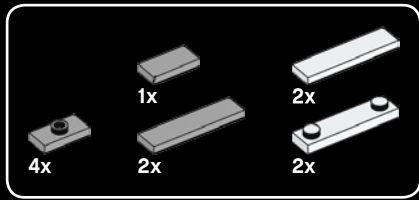

36

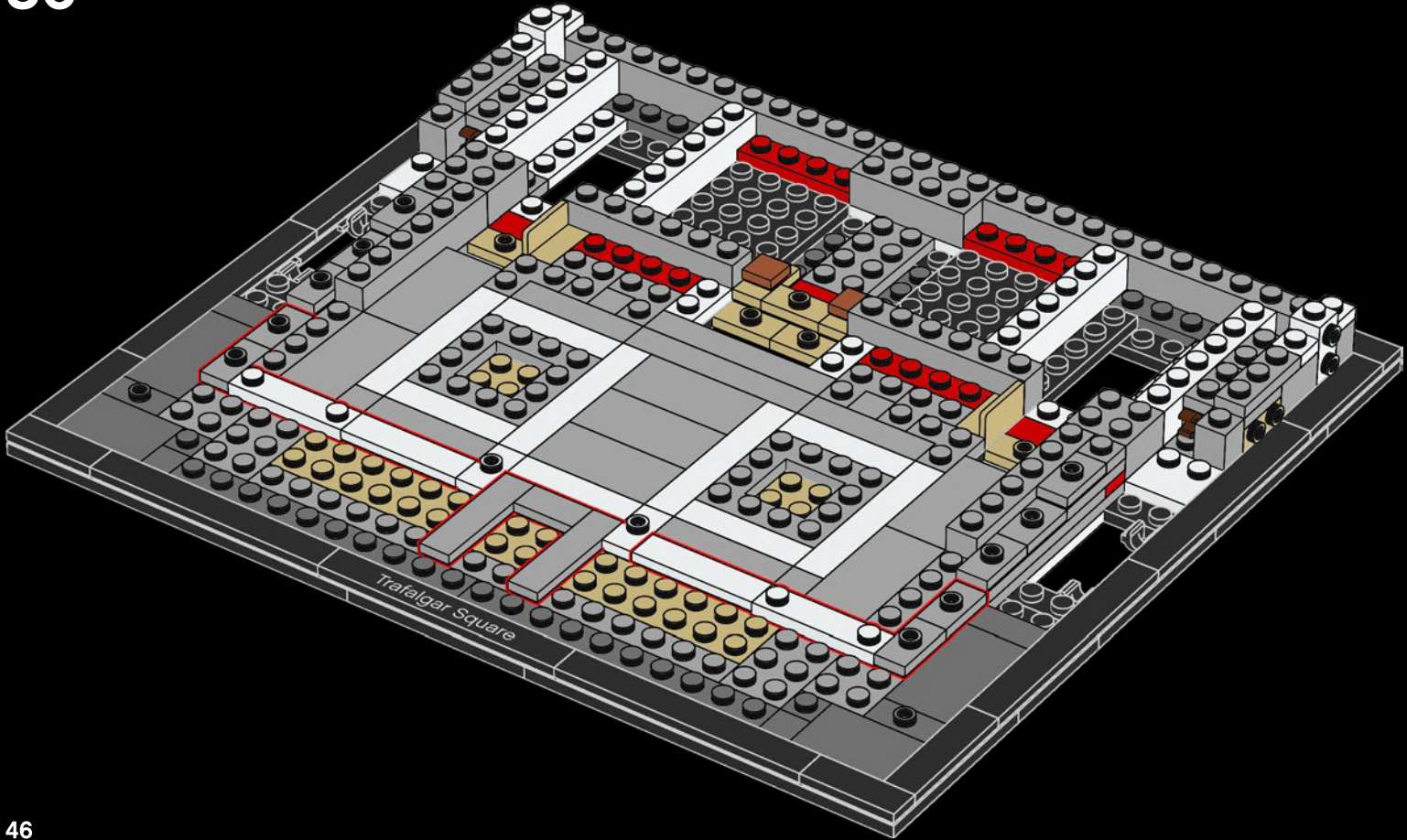



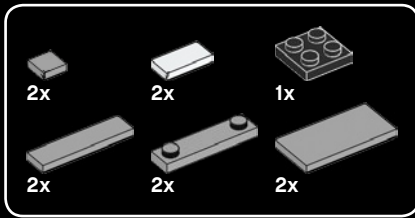

37

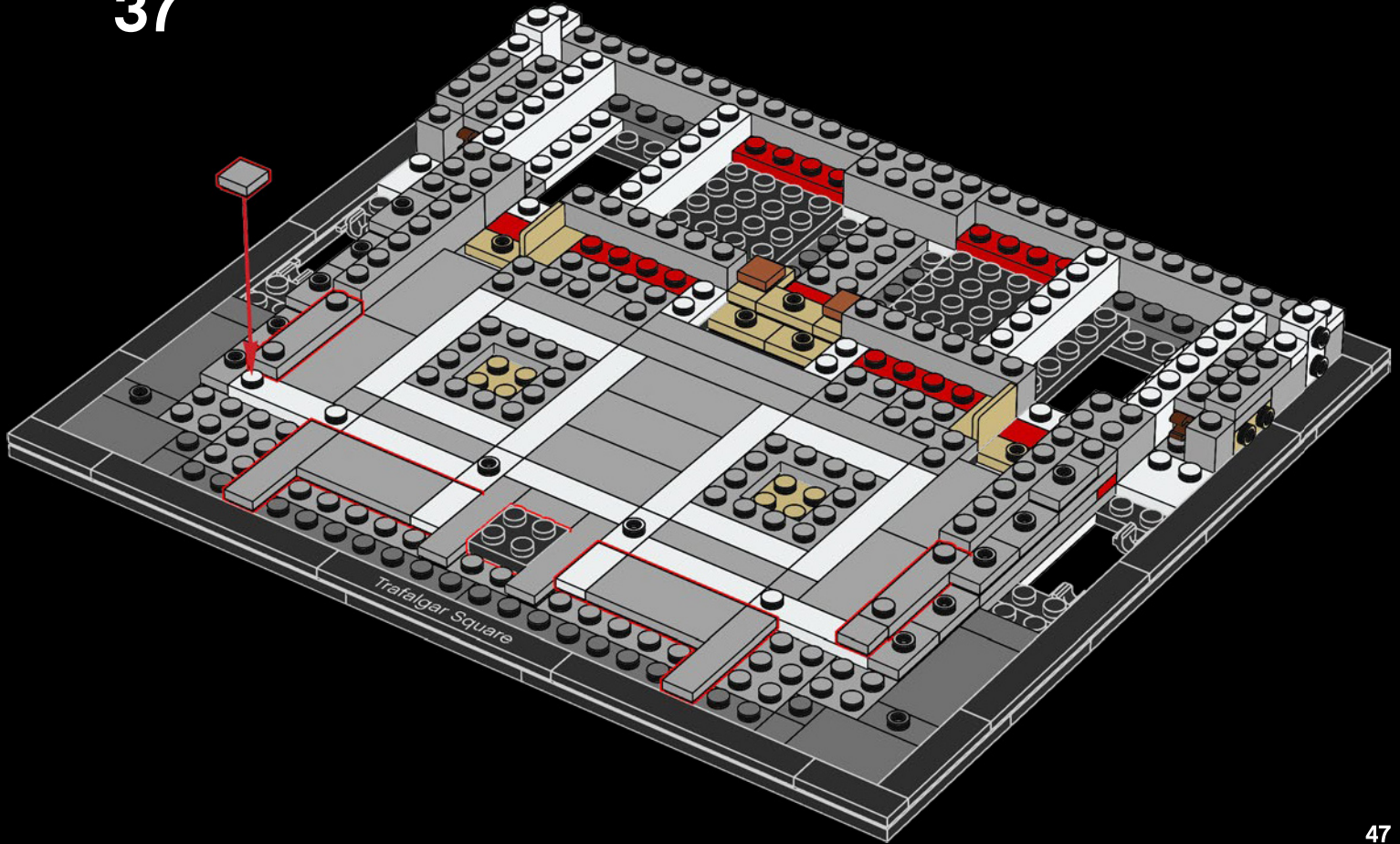

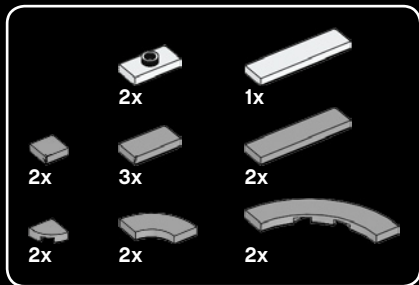

38

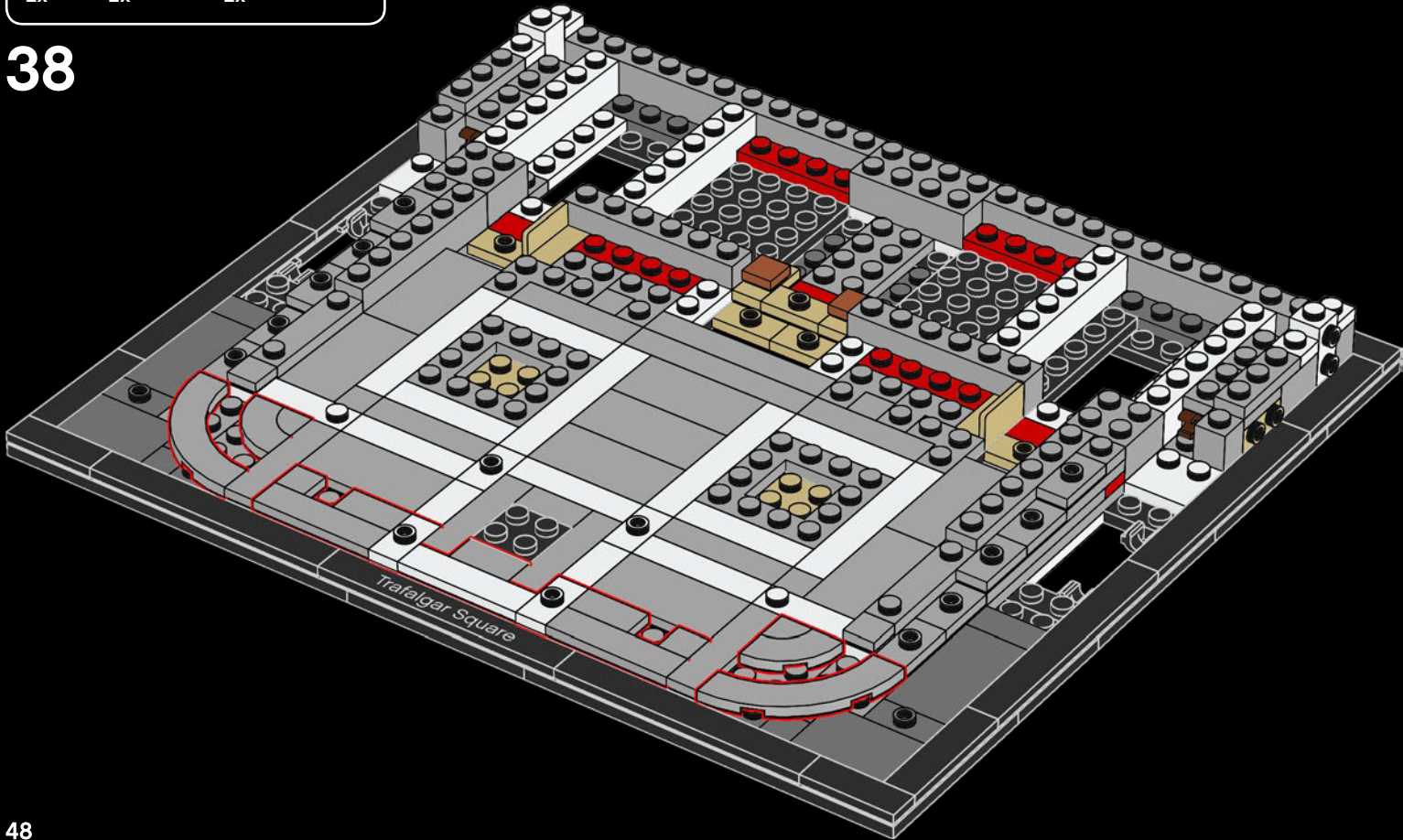



39

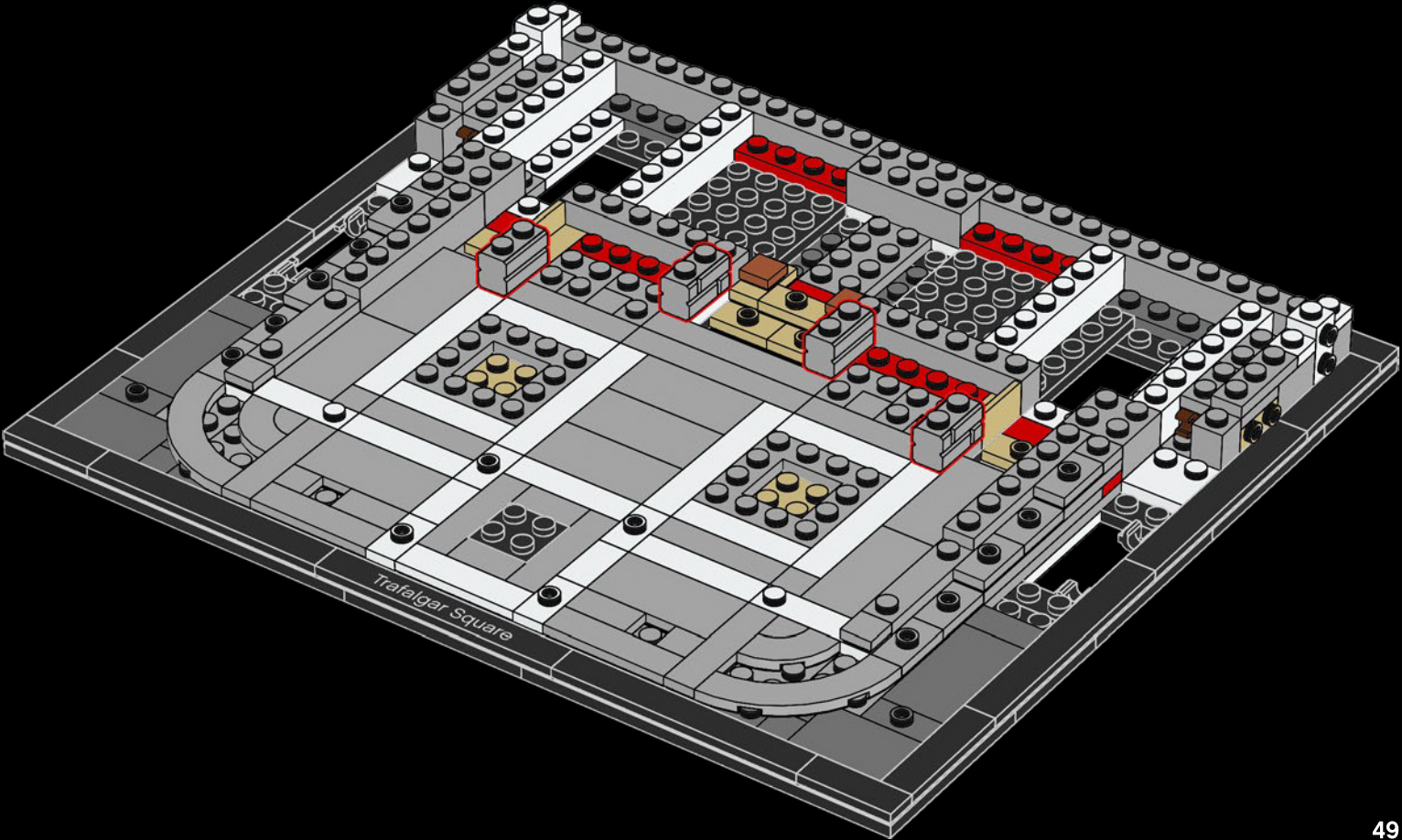



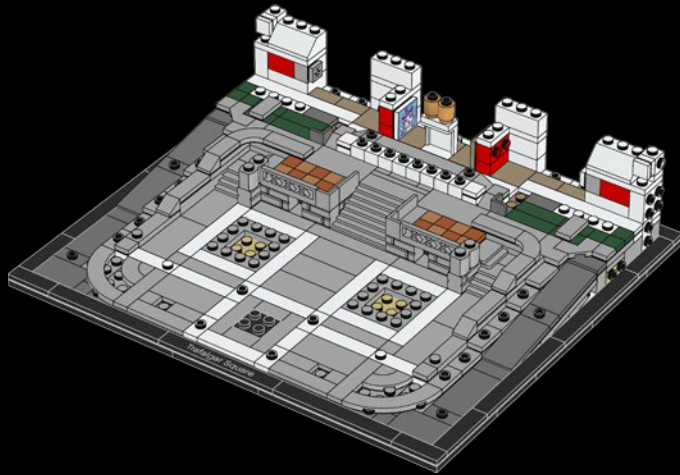





40

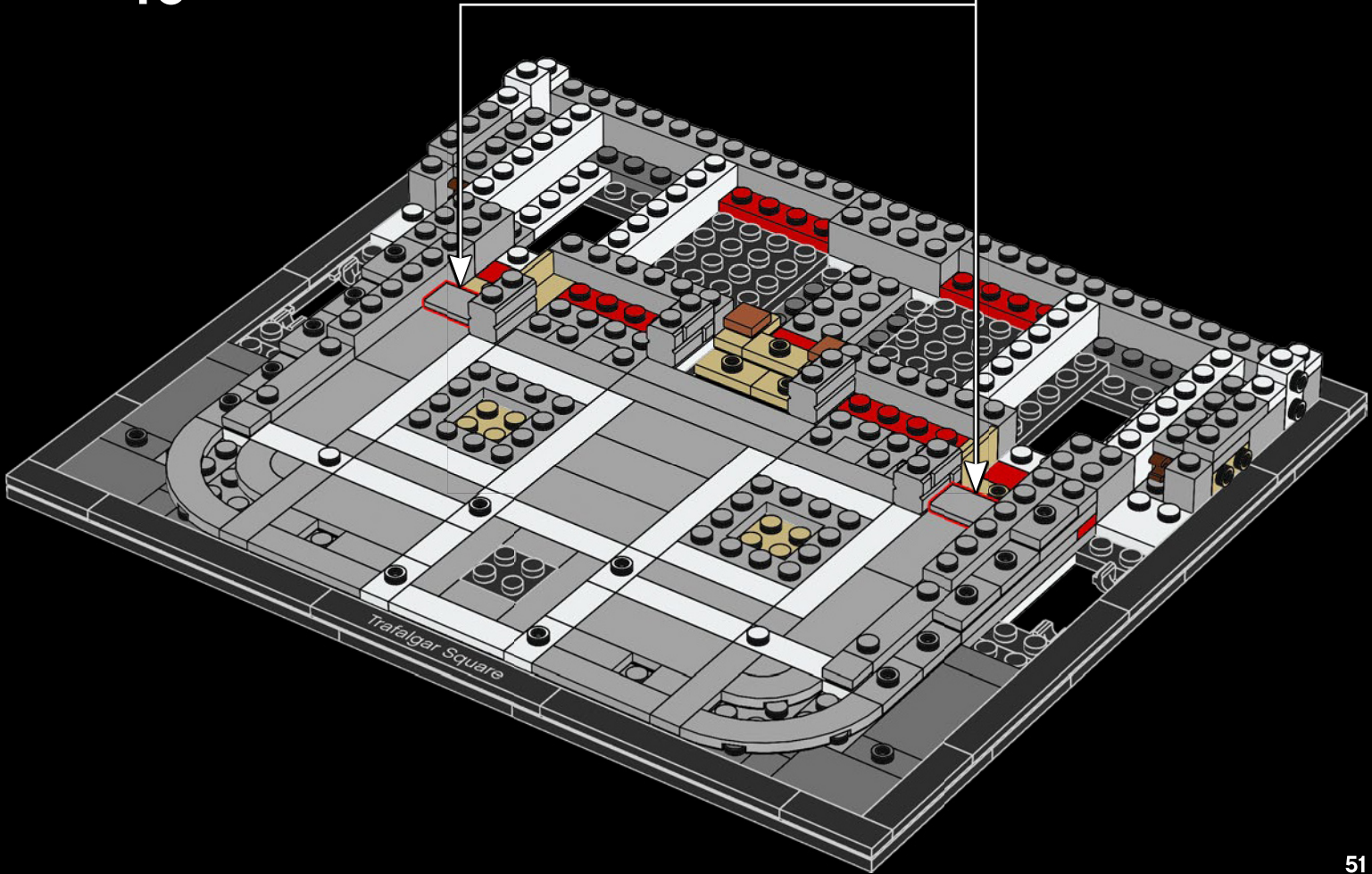



41

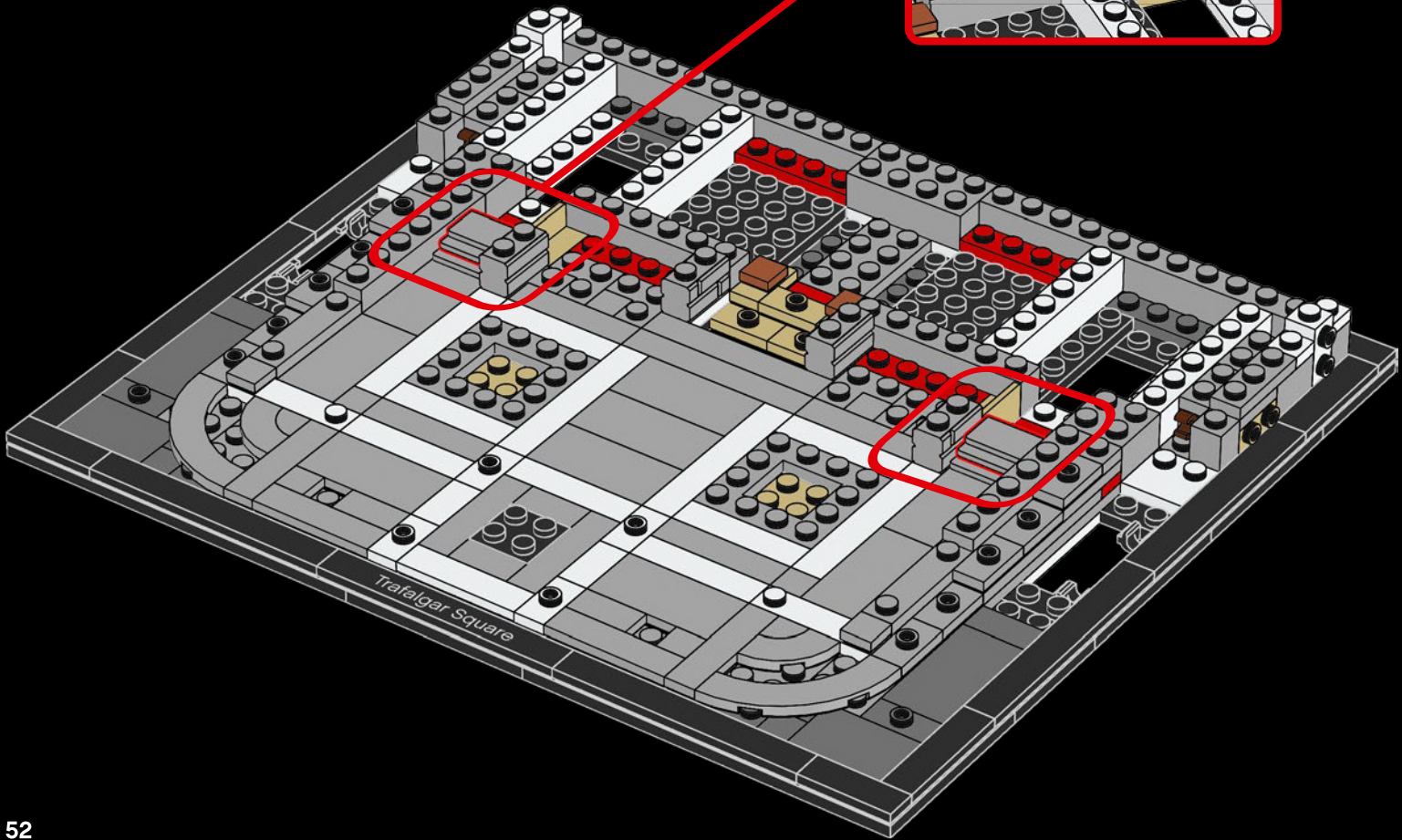
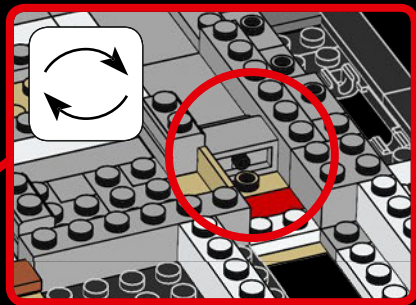
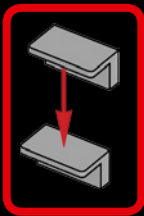

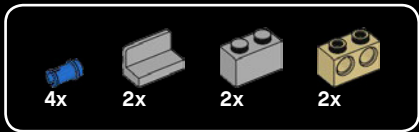

42

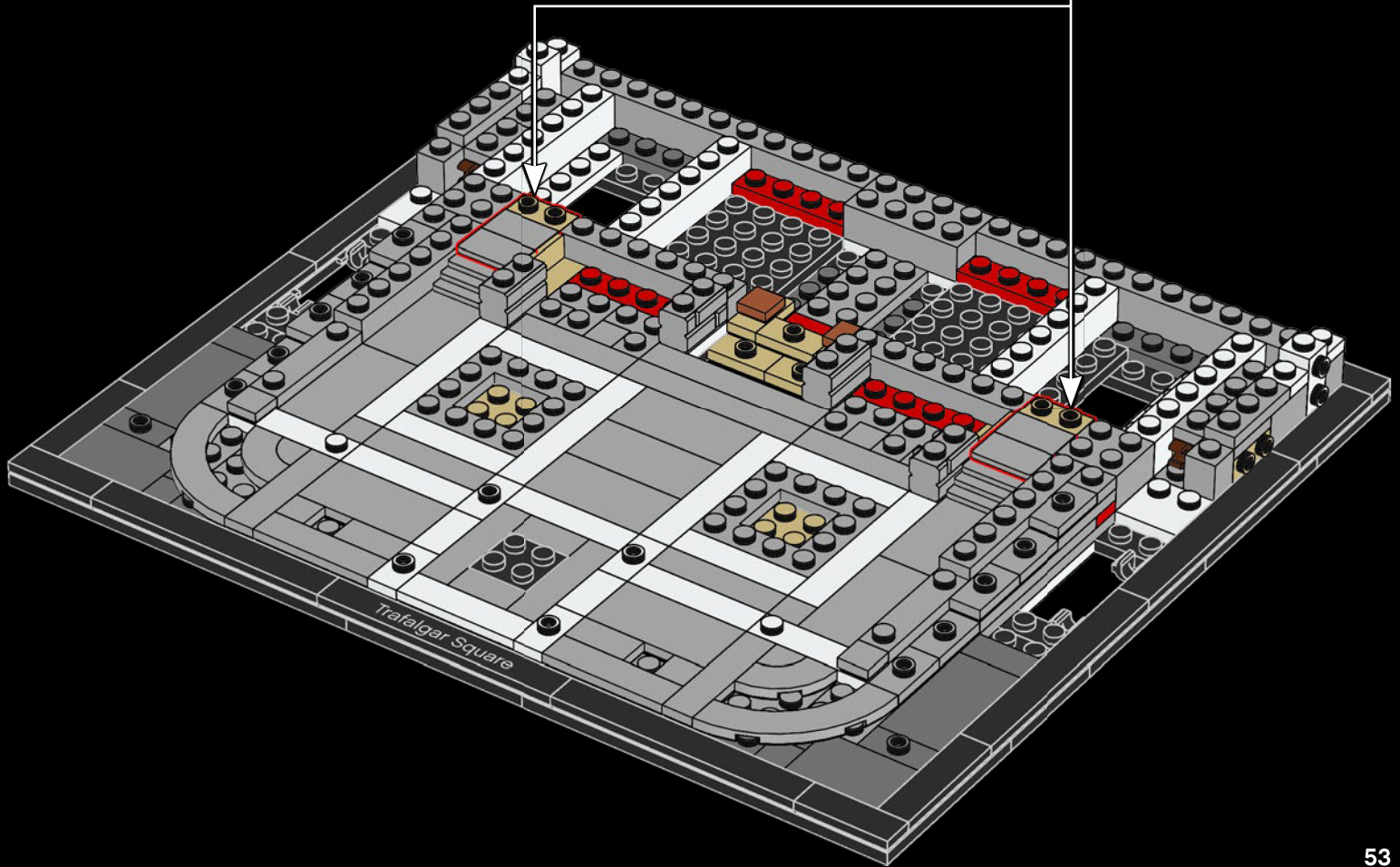
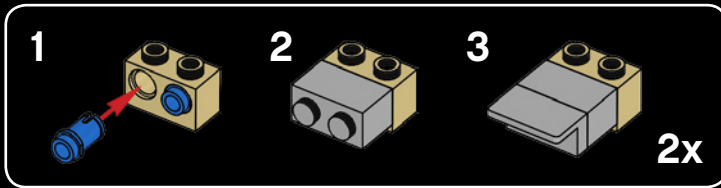





2x



2x

43

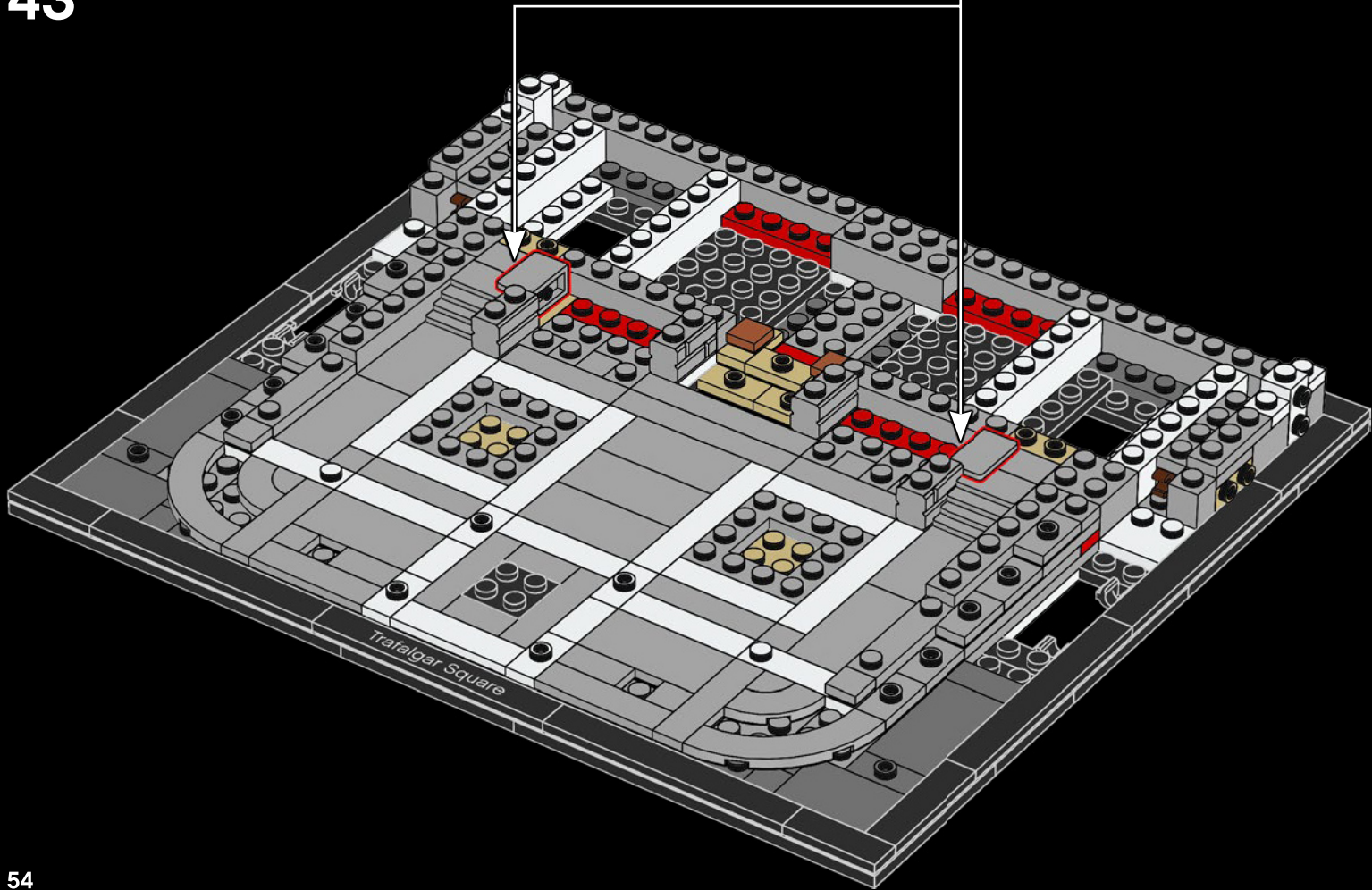

54

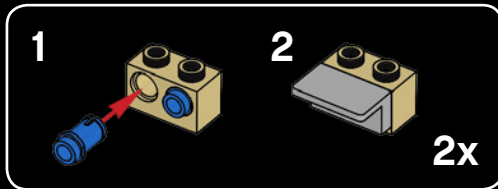

44

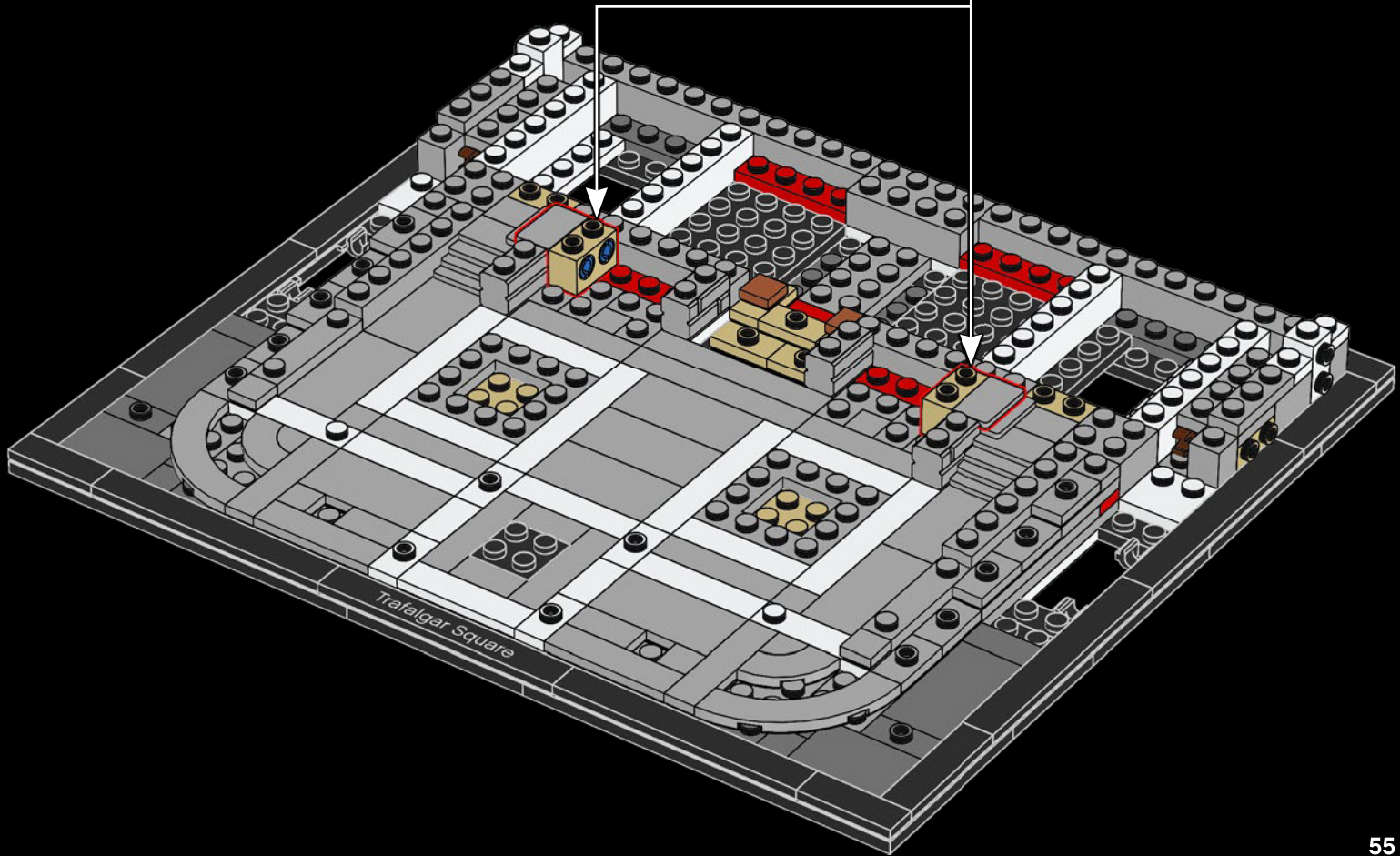

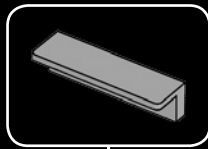
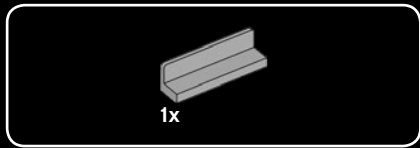

45

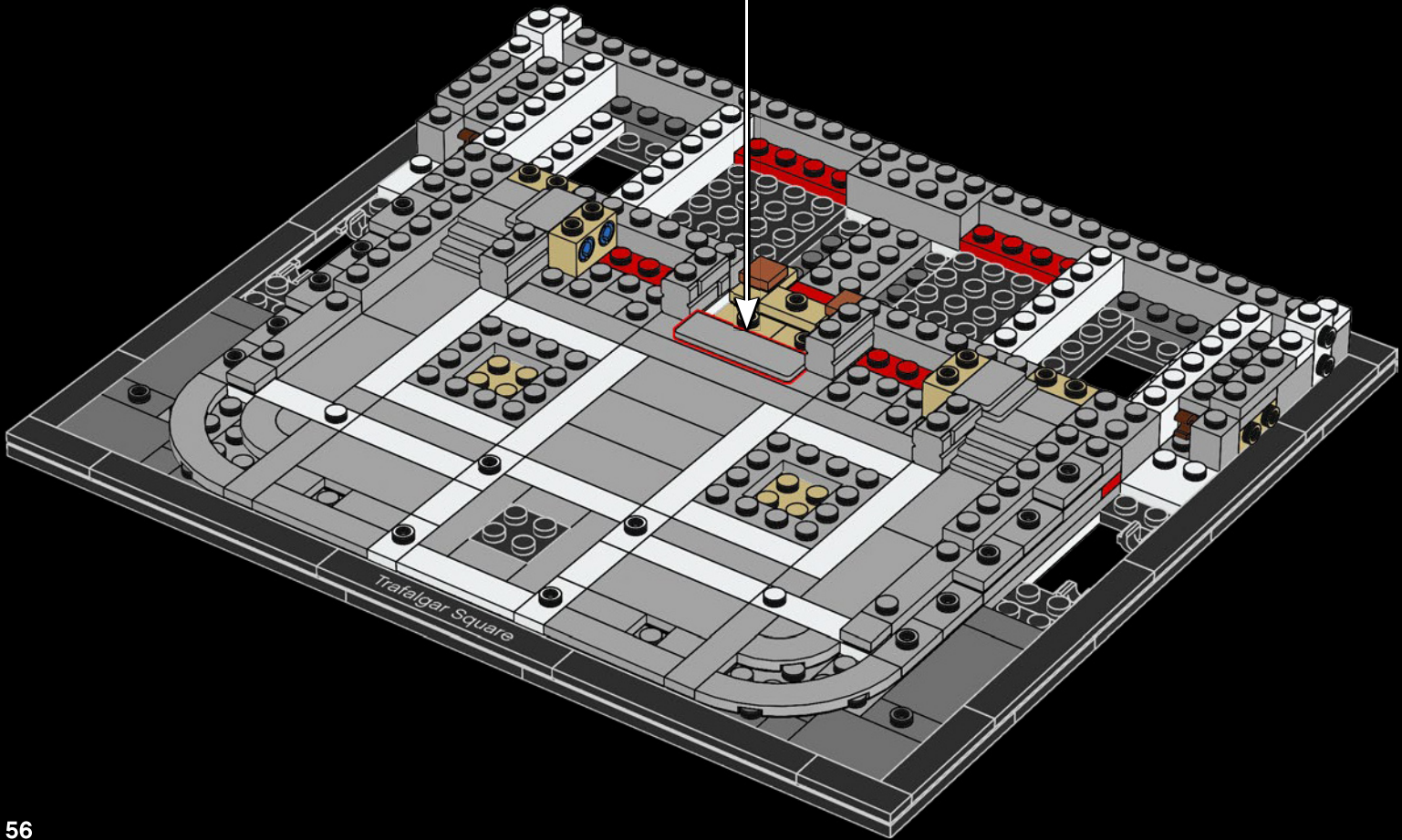



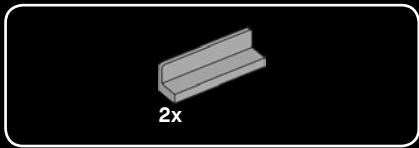

46

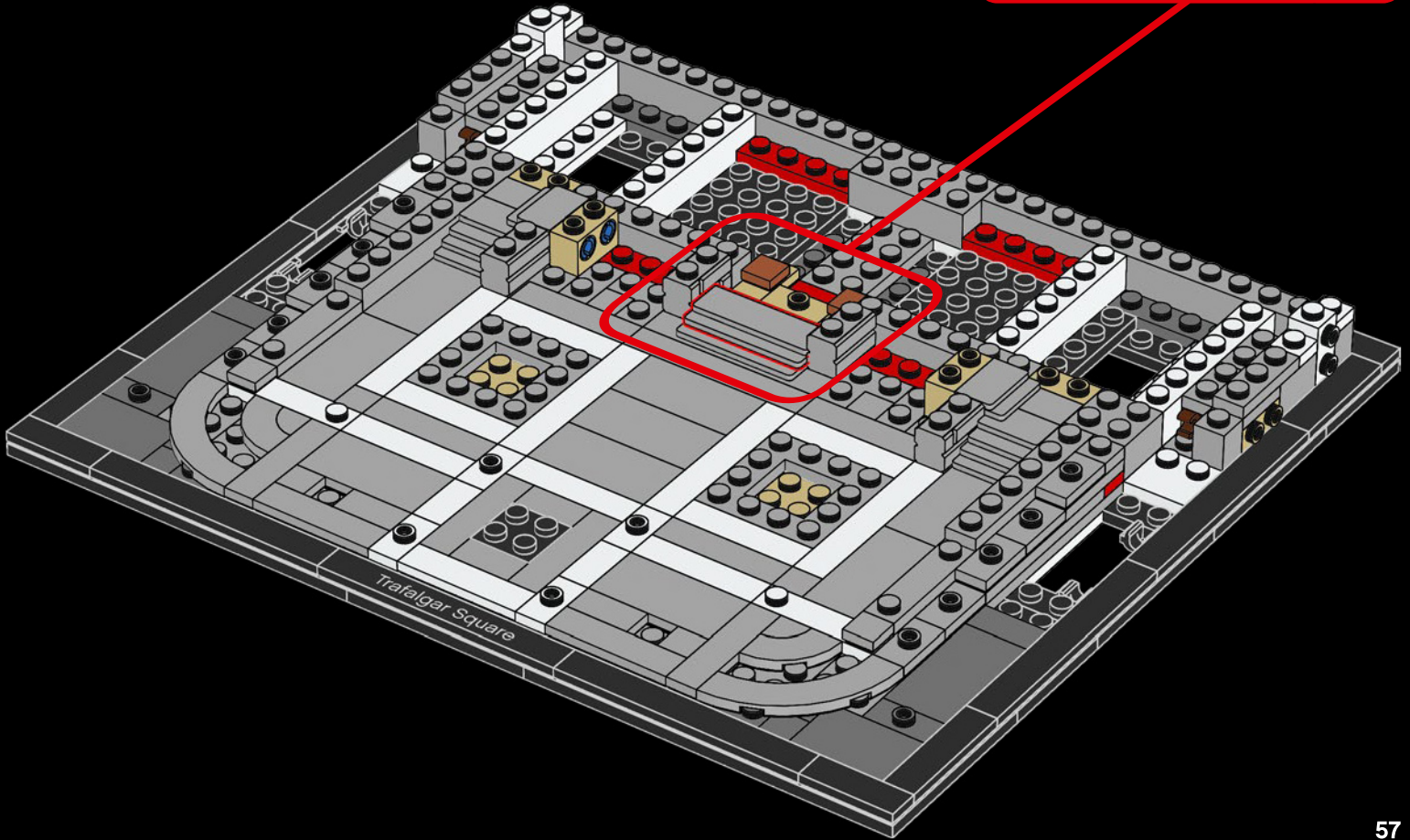
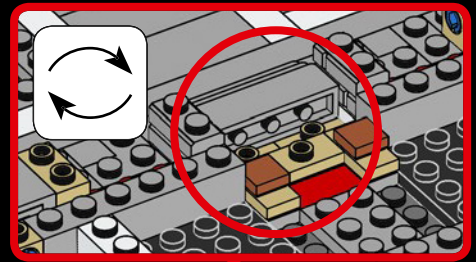
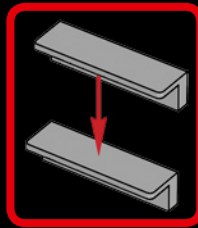

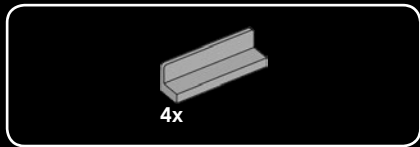

47

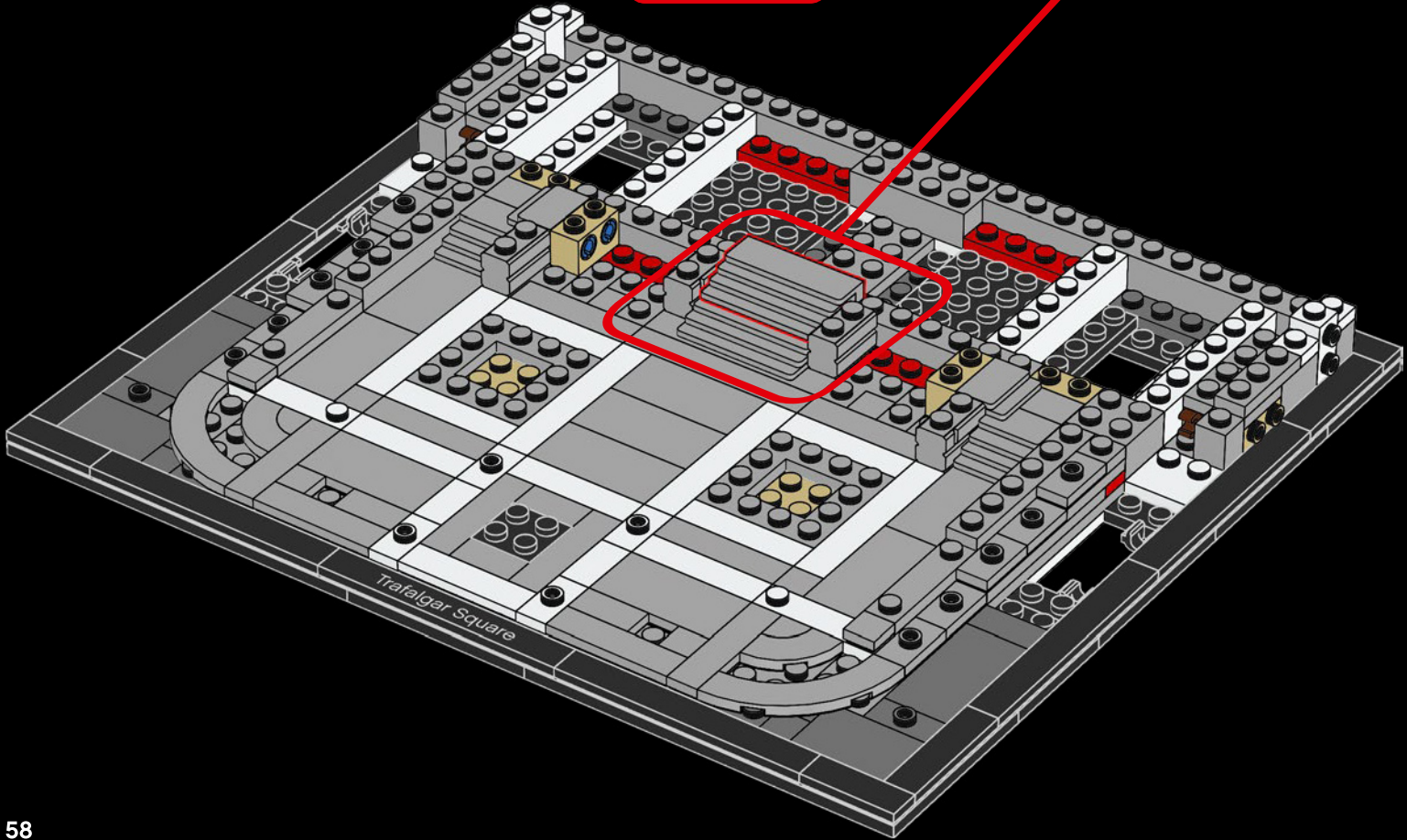
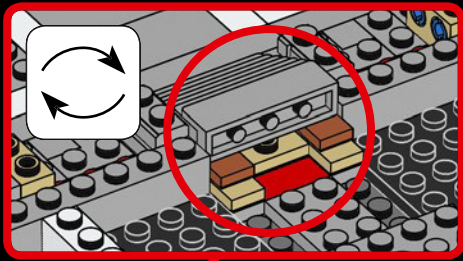
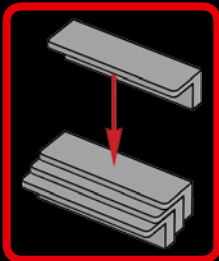

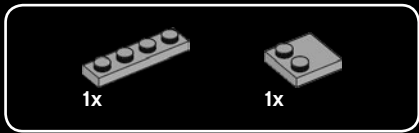

48

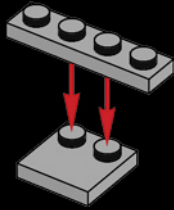

49

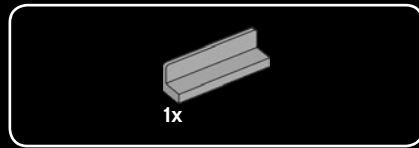
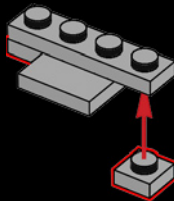

50

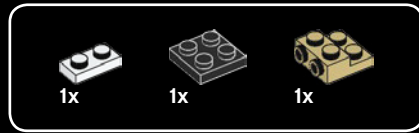
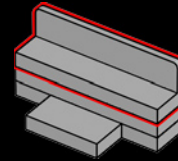

51

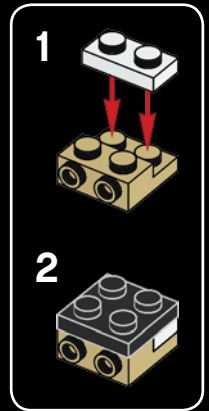
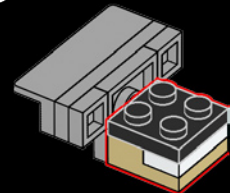



52

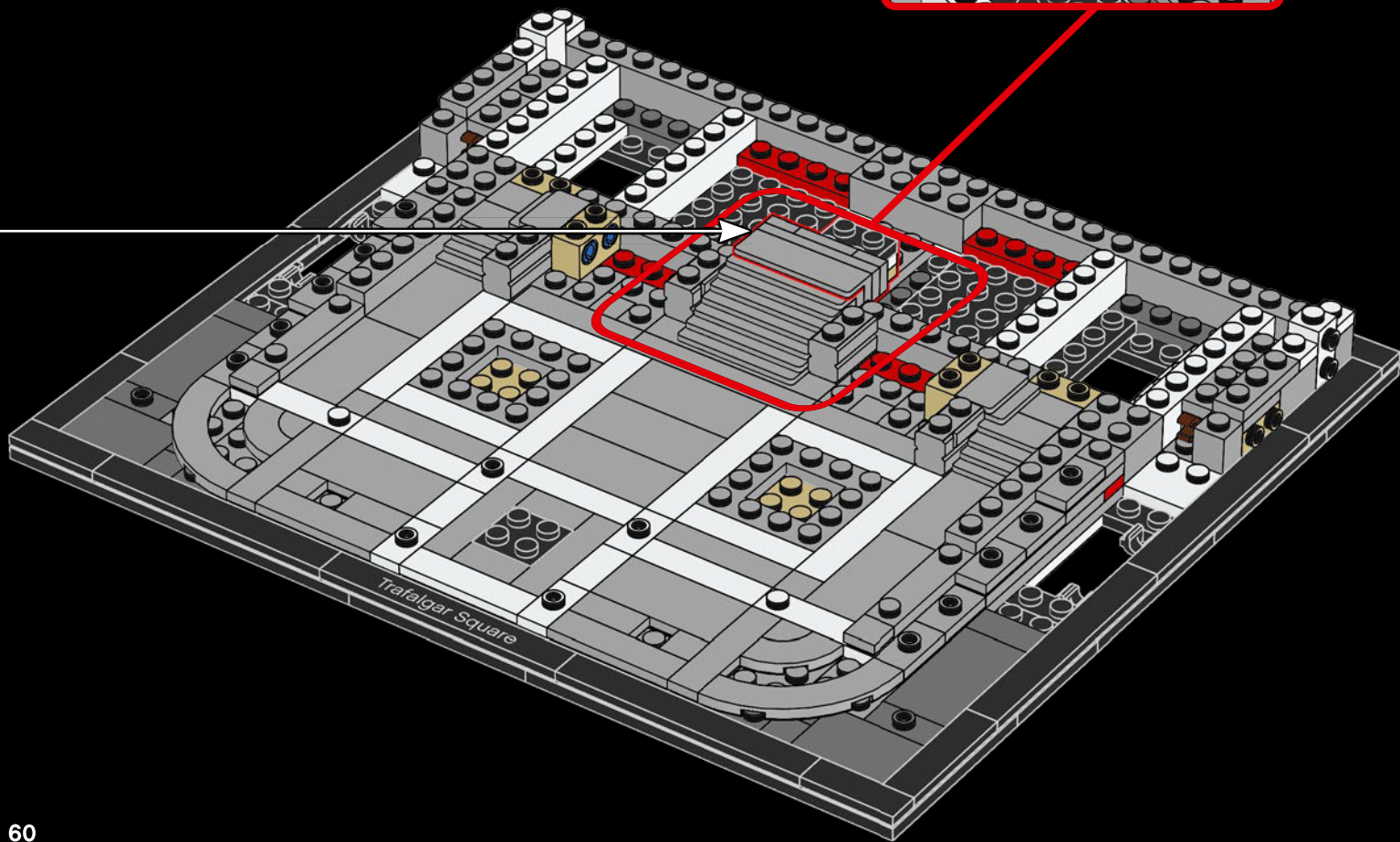
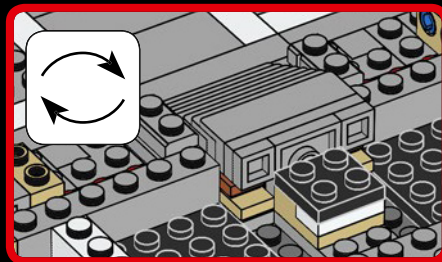

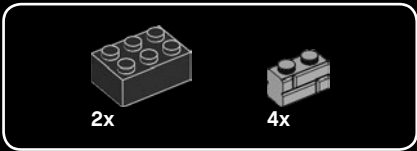

53

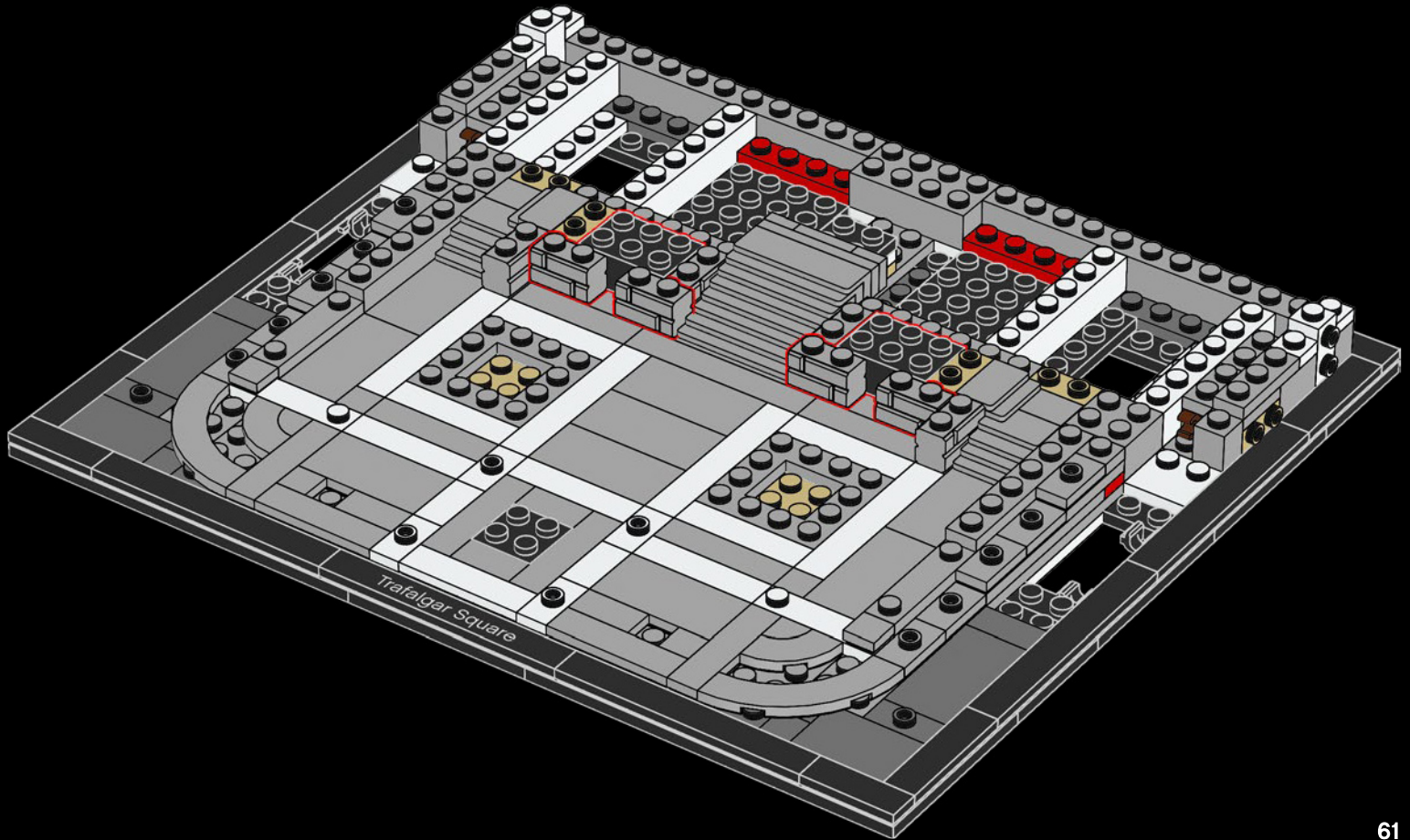

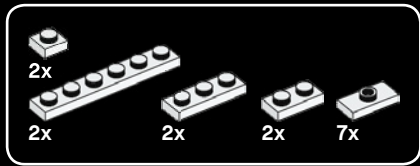

54

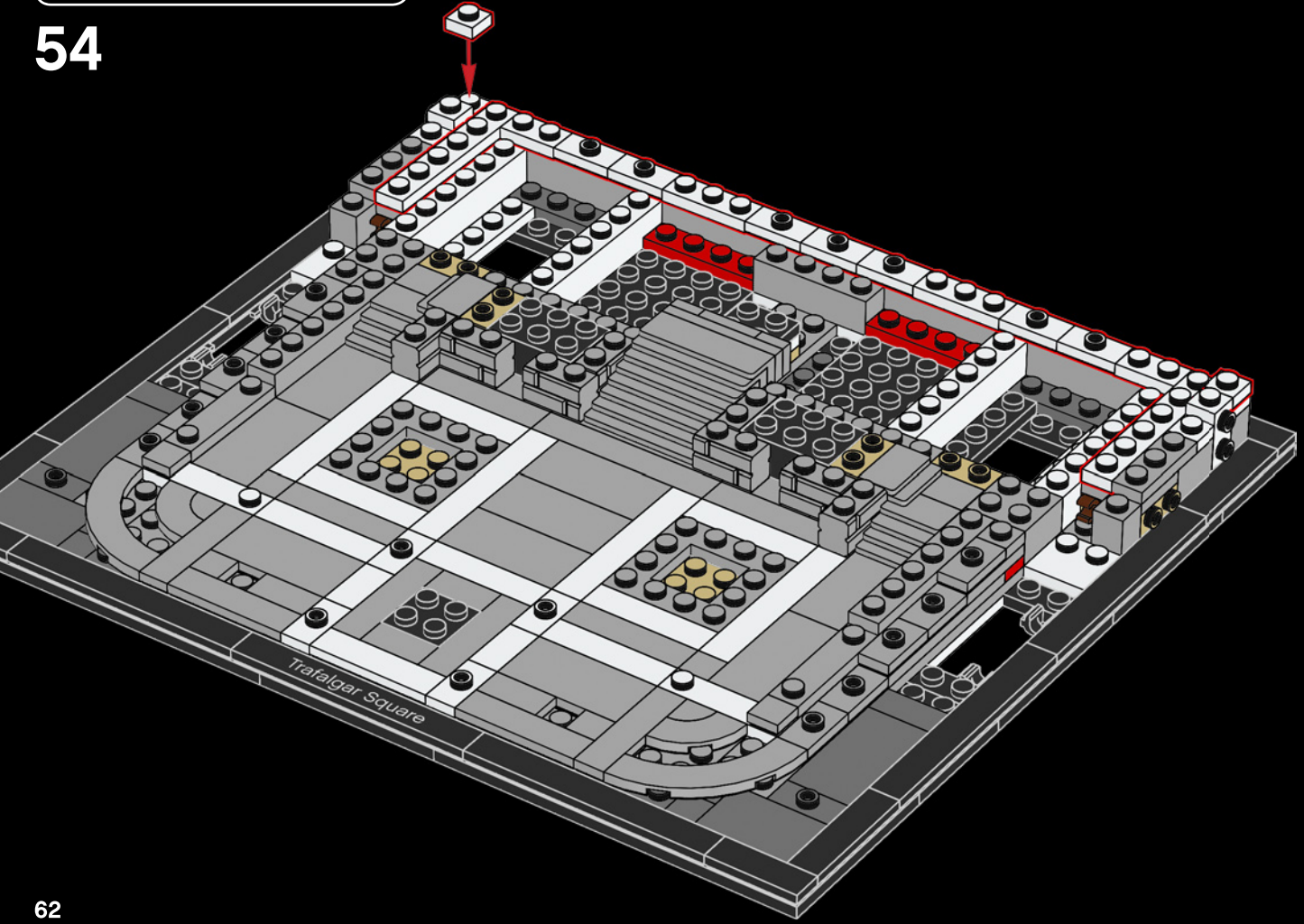



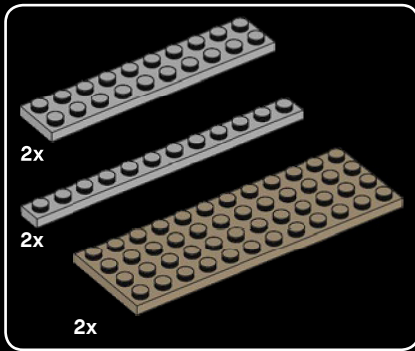

55

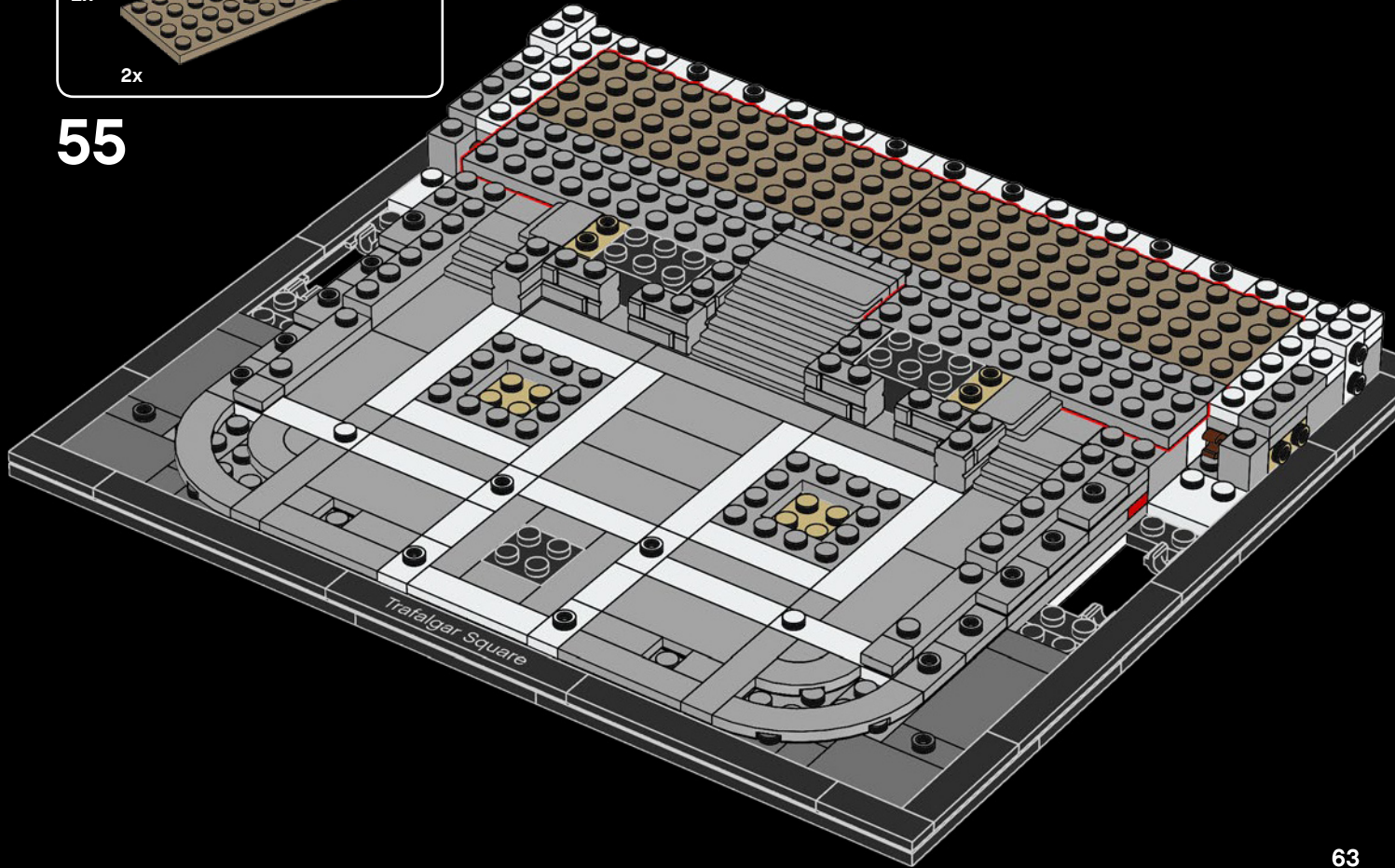

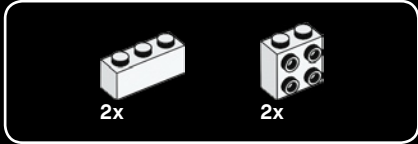

56

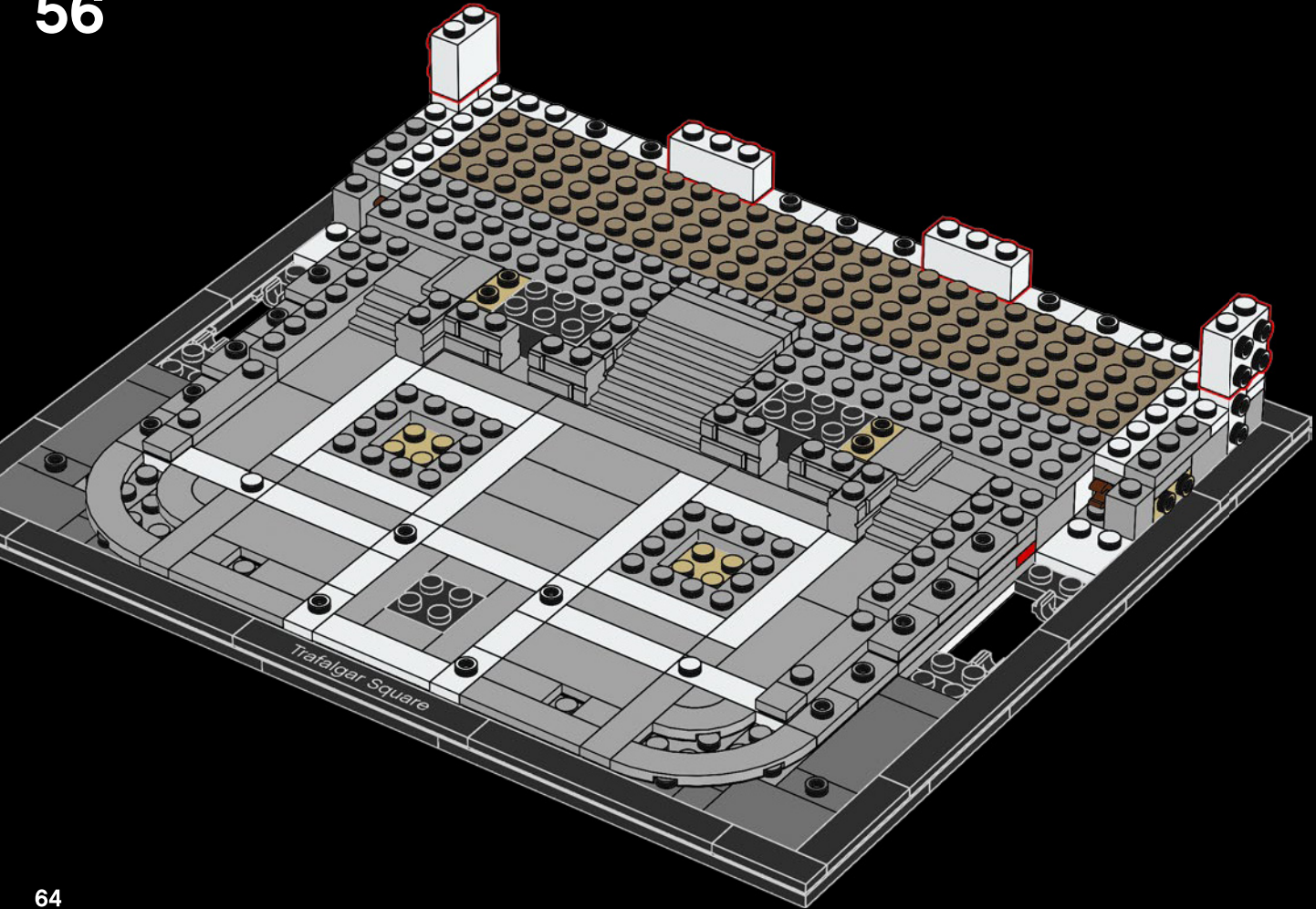

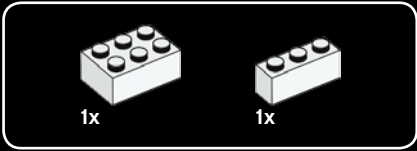

57

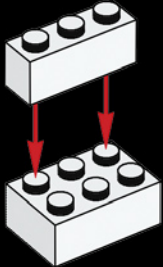

58

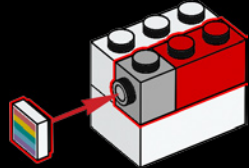



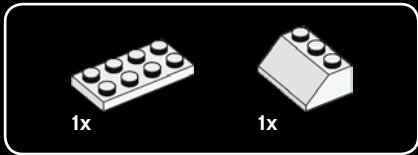

59



60

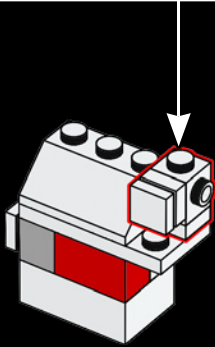
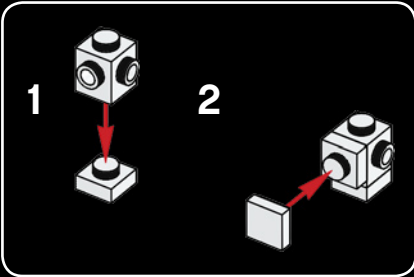

61

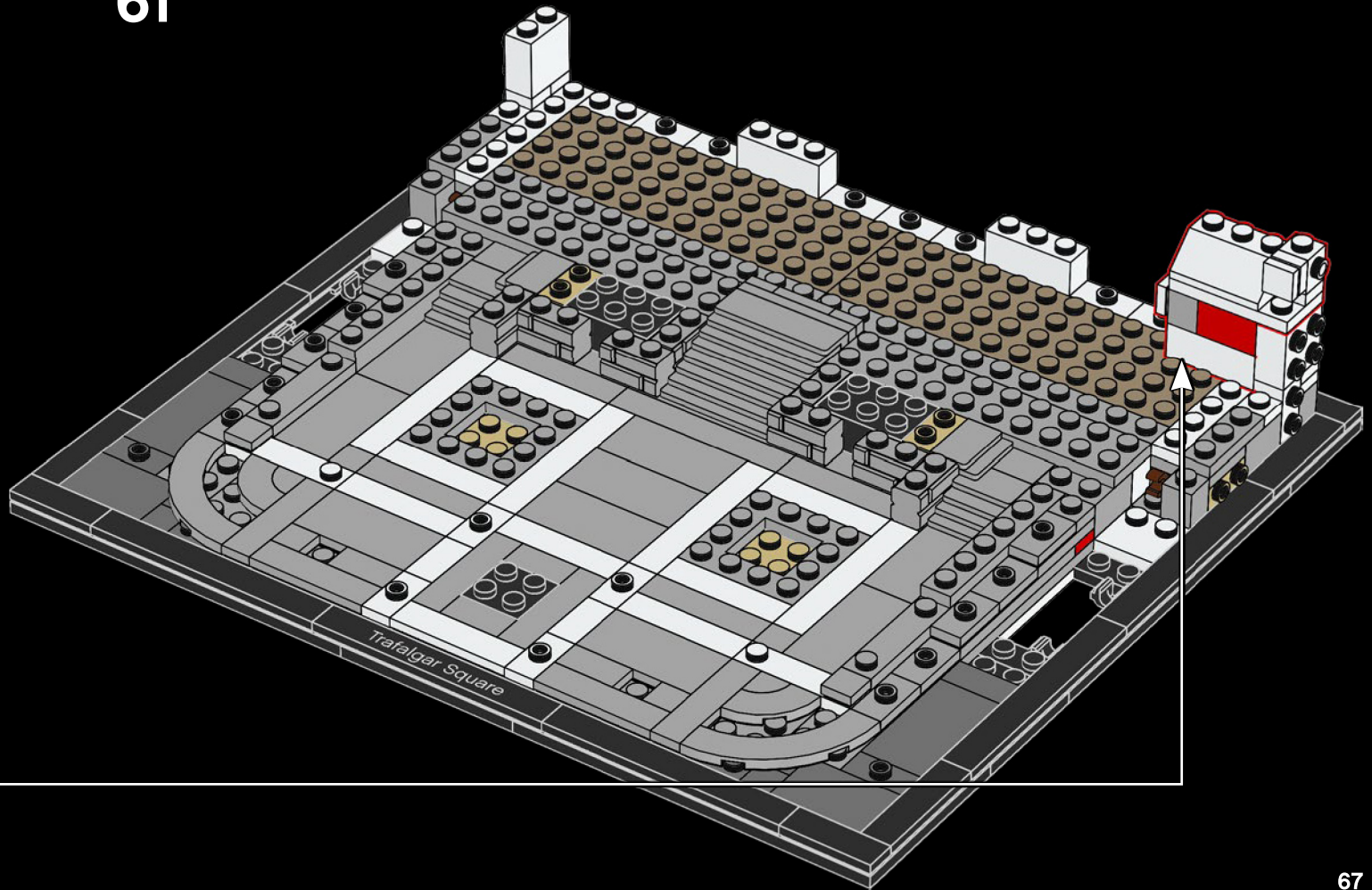

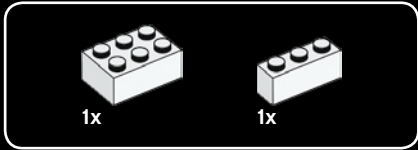

62

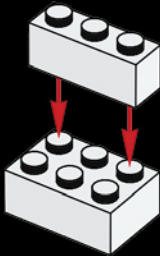

63

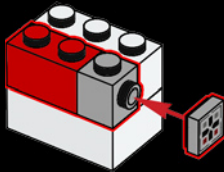



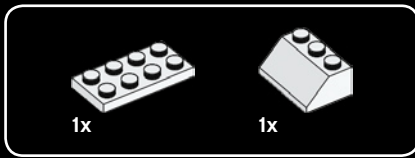

64

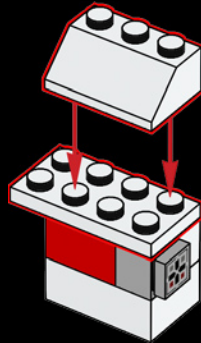

65

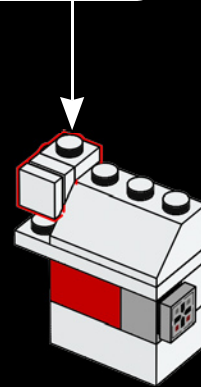
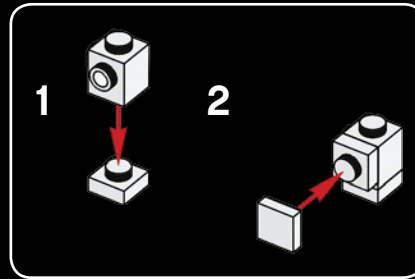

66

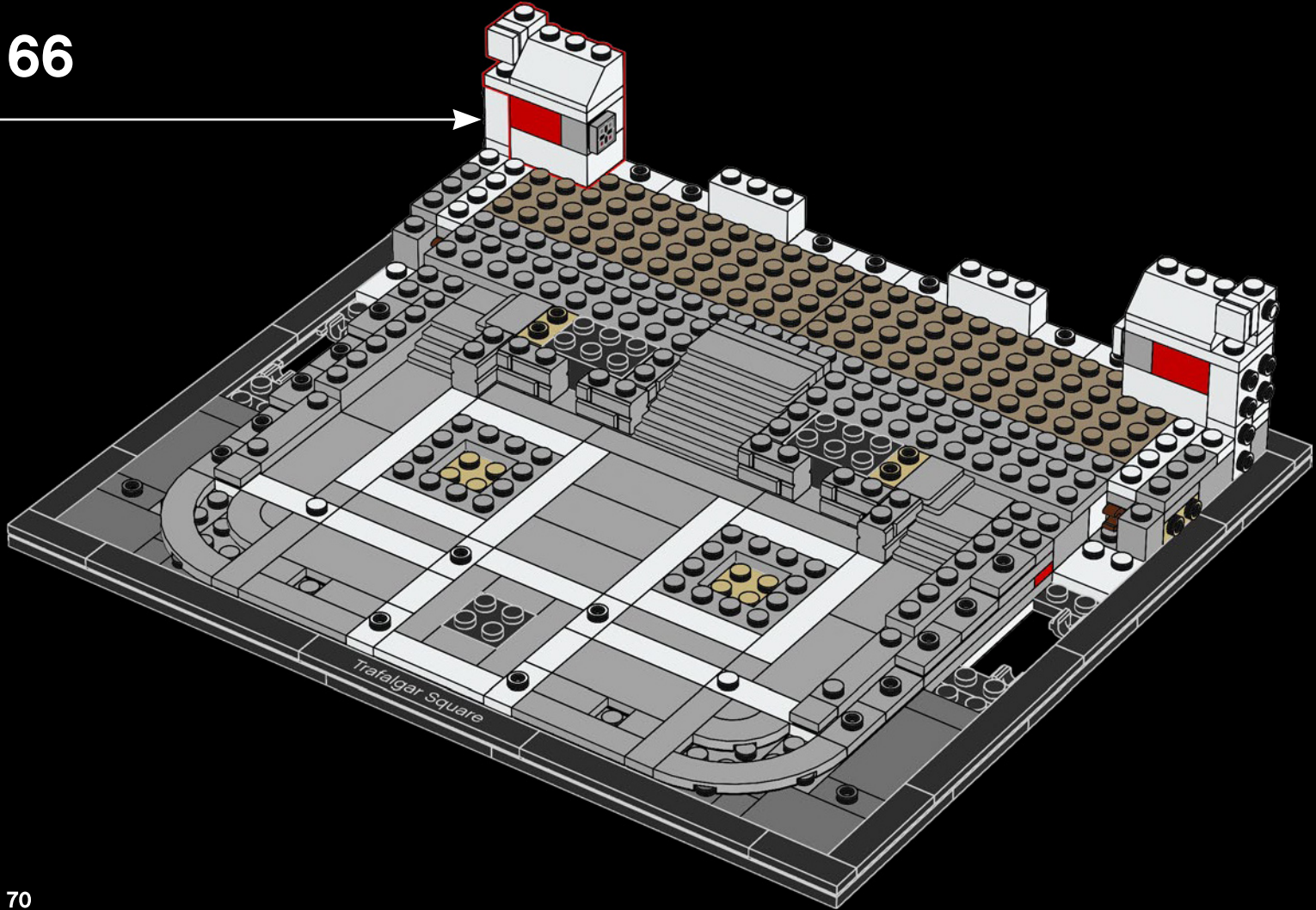

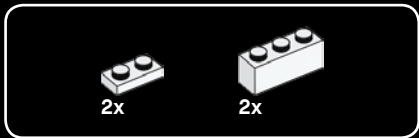

67

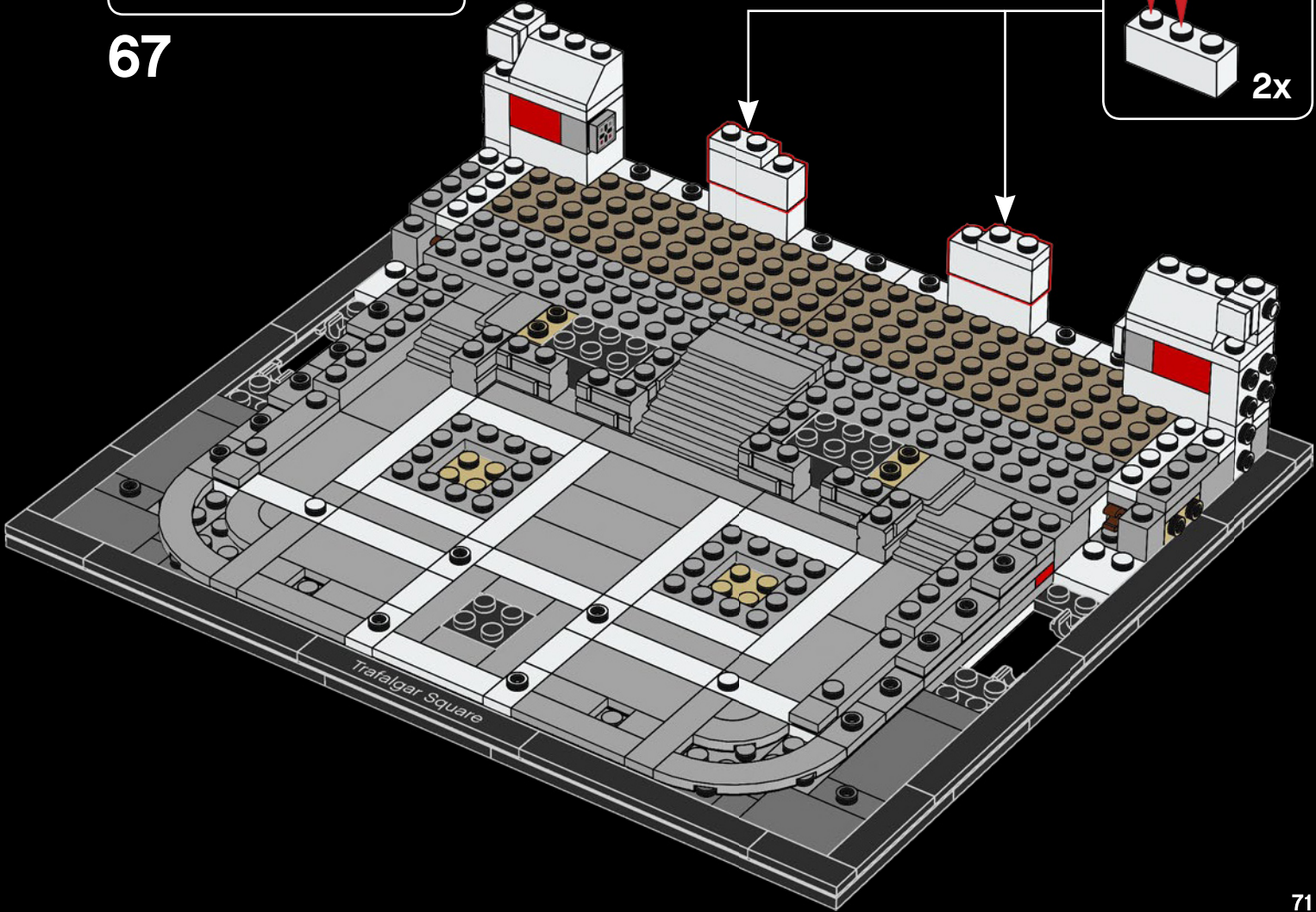
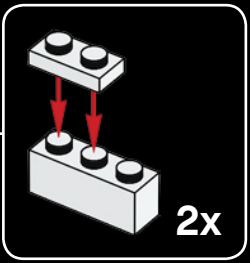



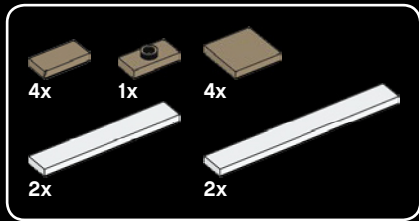

68

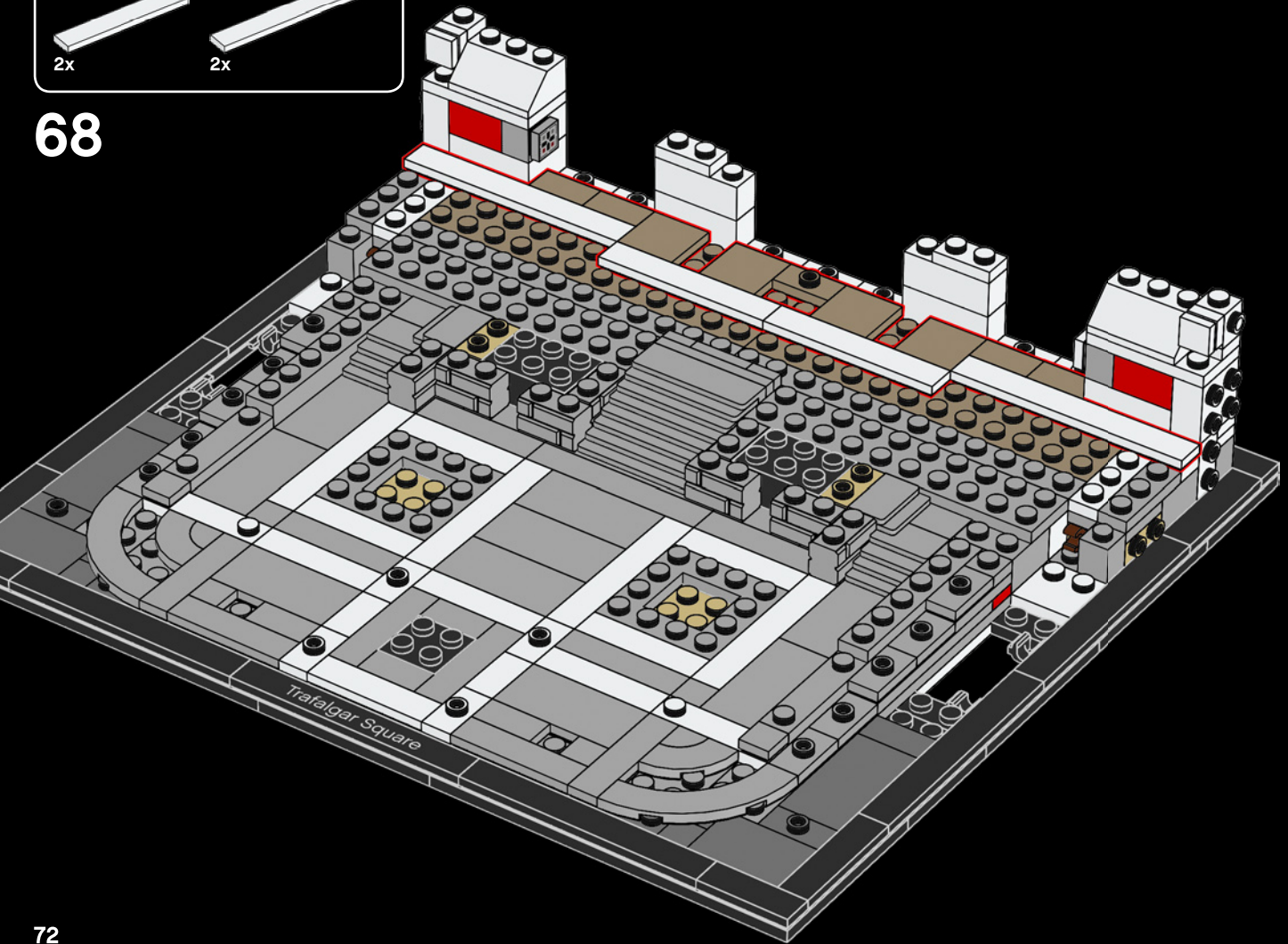

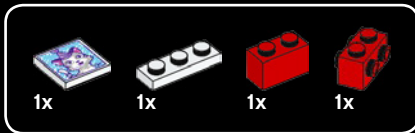

69

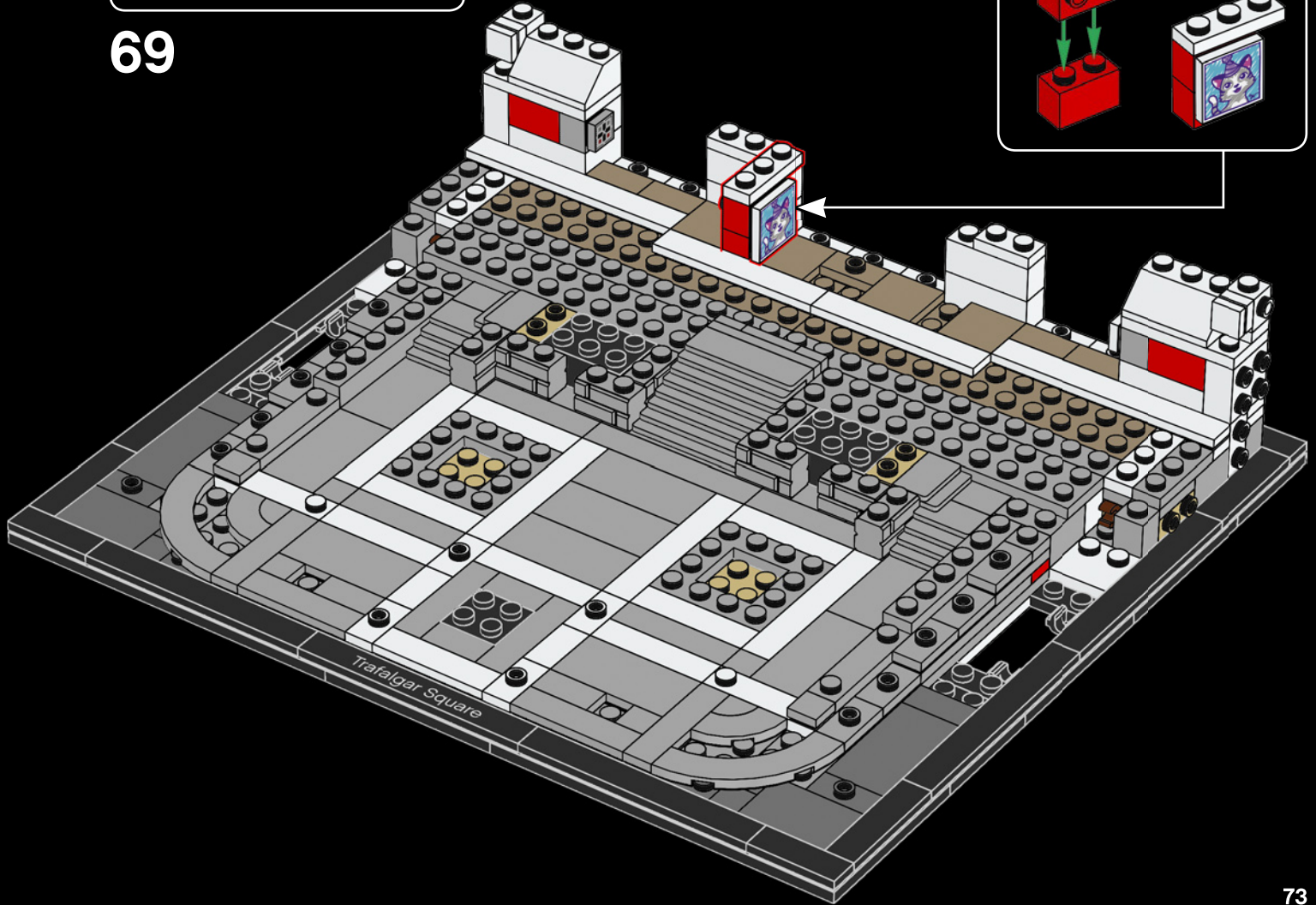
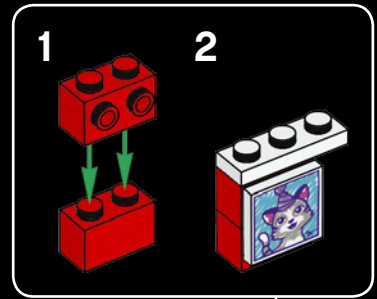

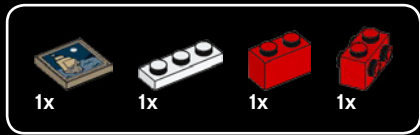

70

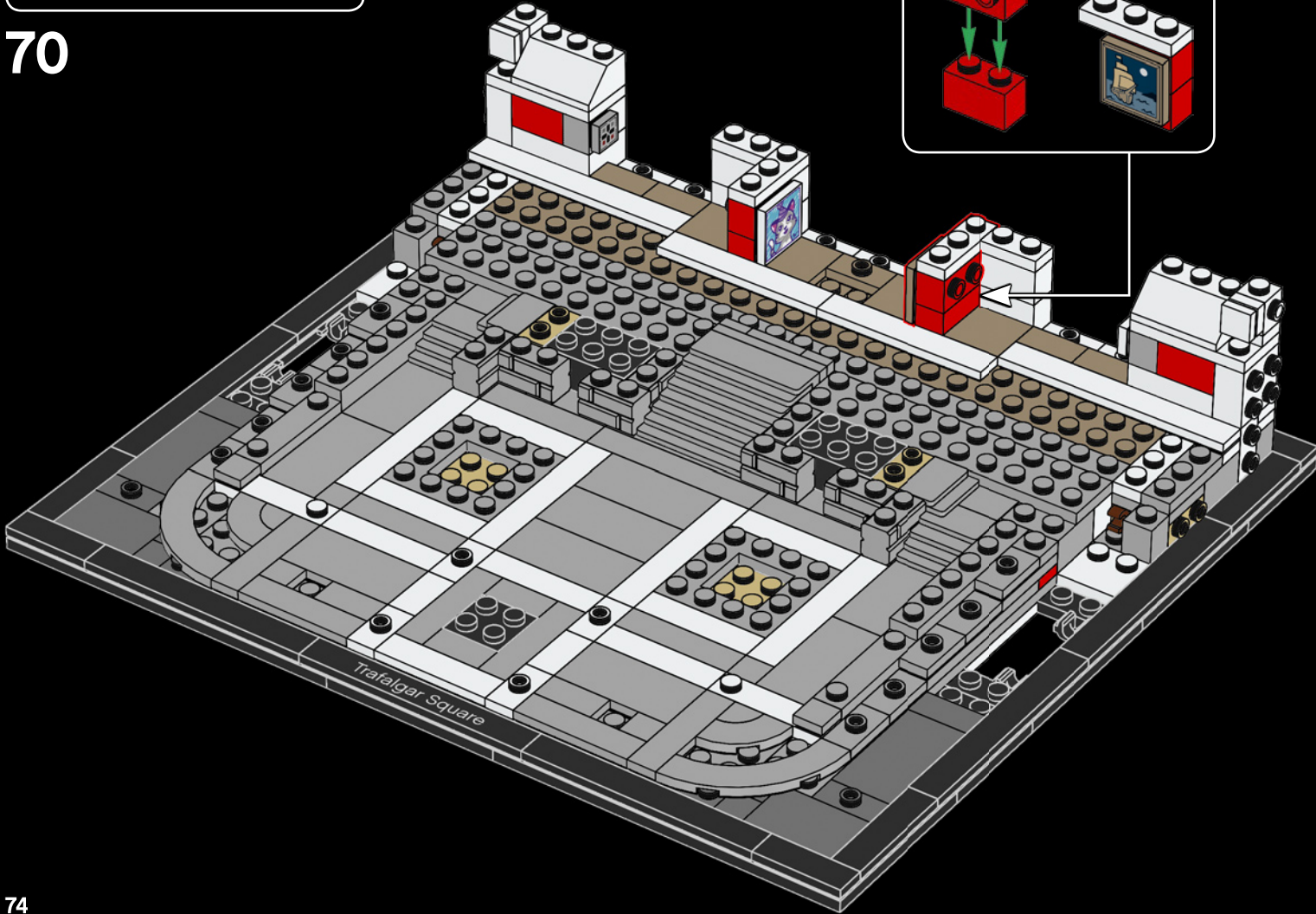
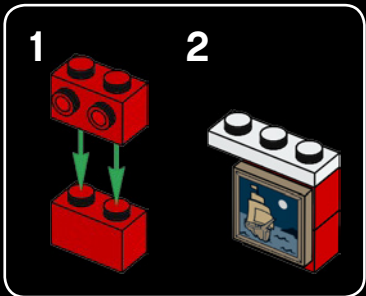





71

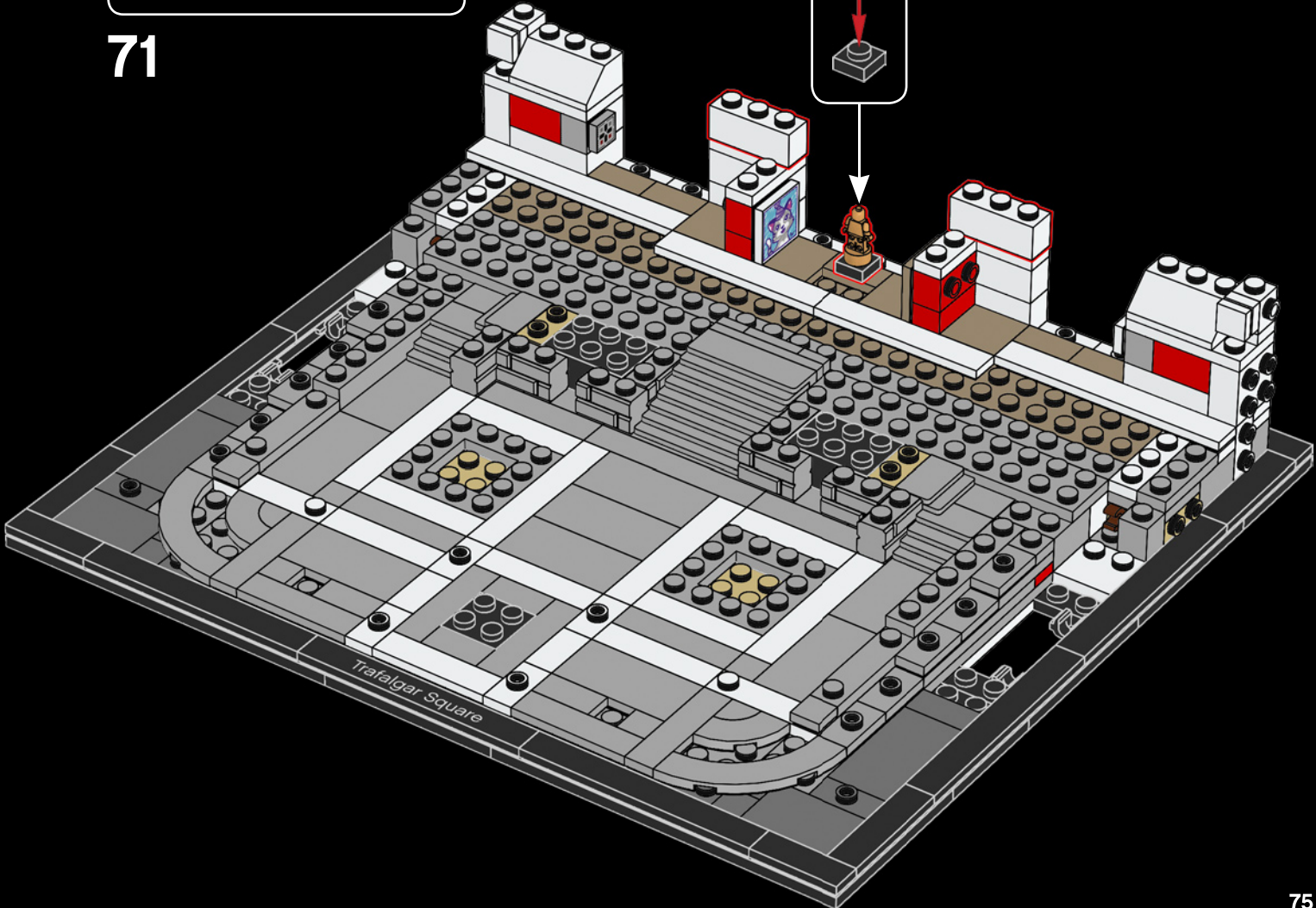
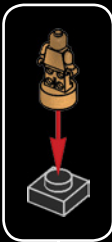



72

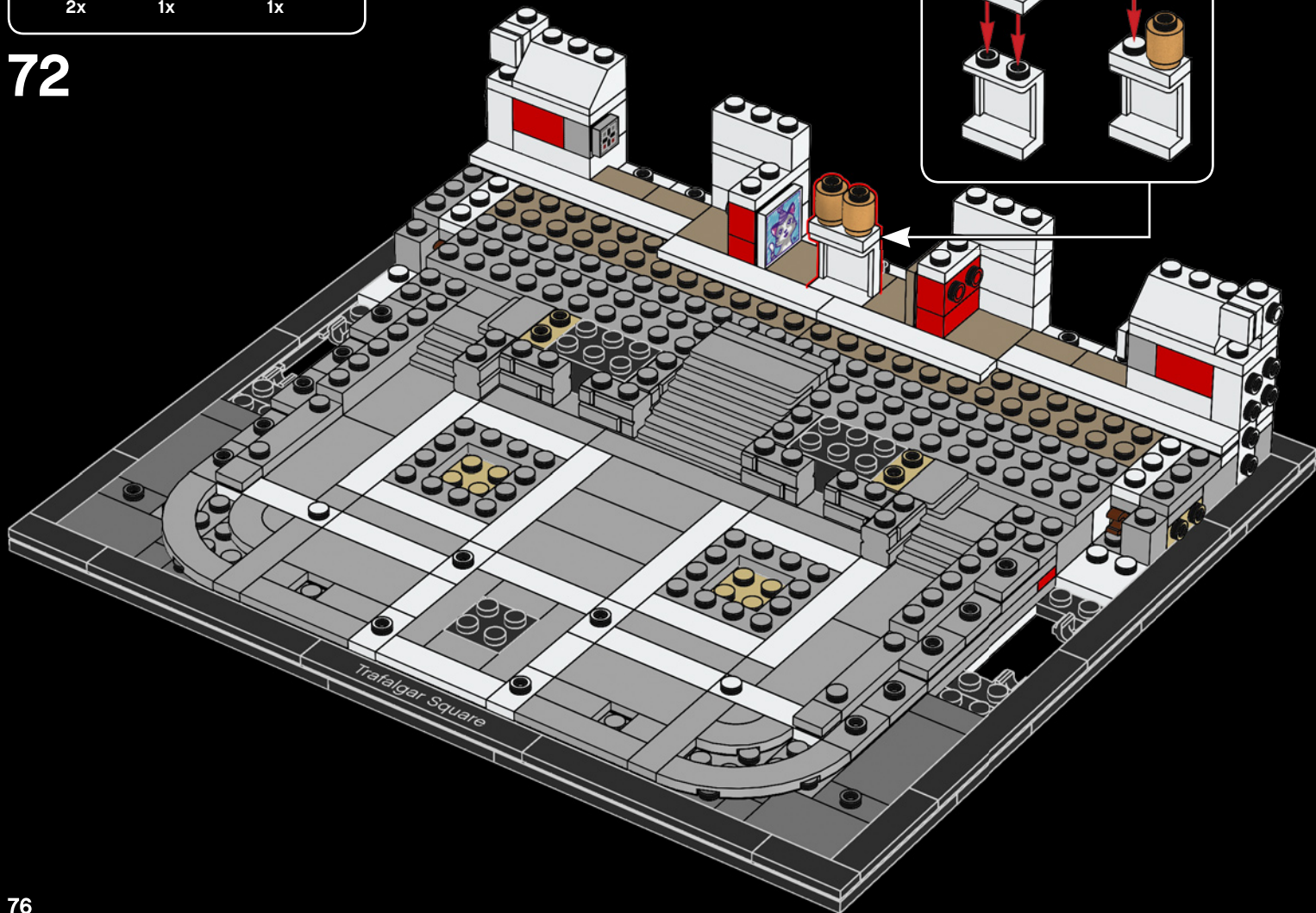
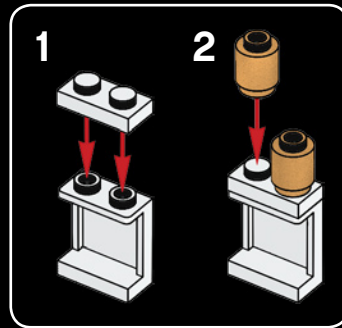

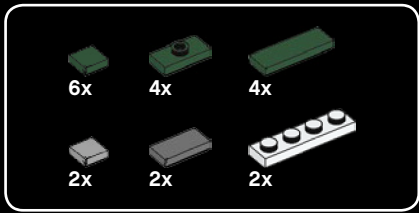

73

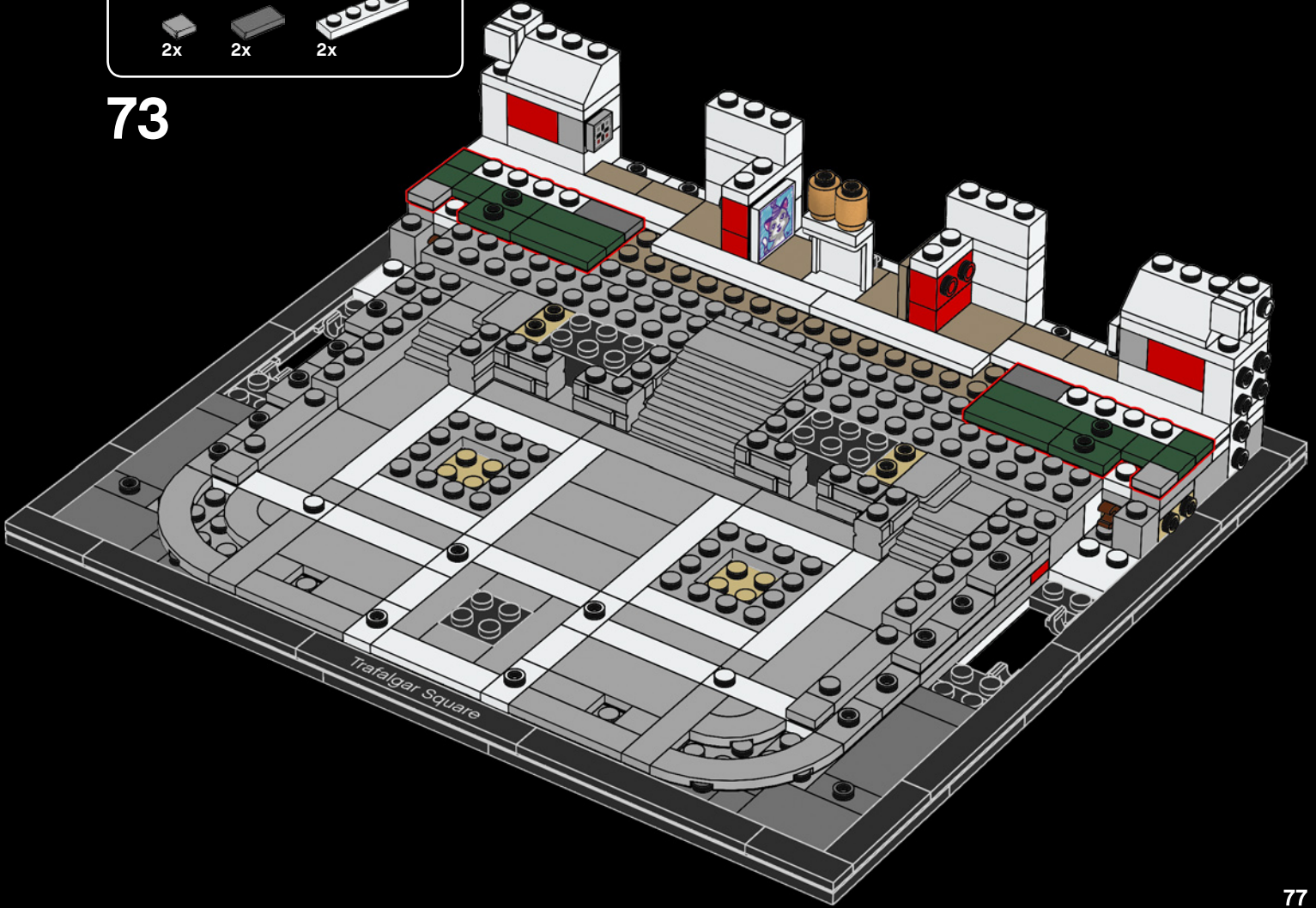



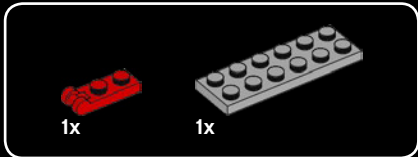
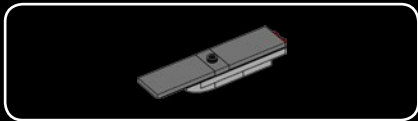

74

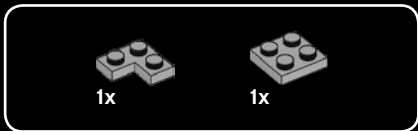
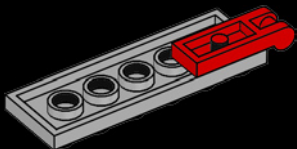

75

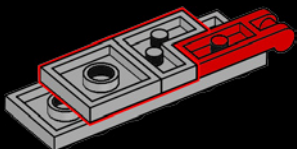

76

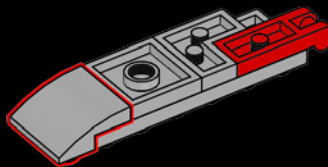

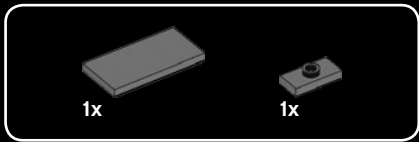

77

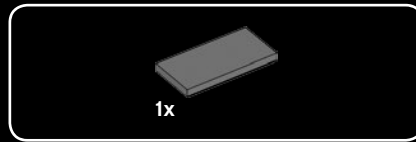
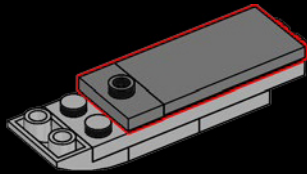

78

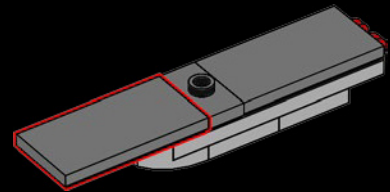

79

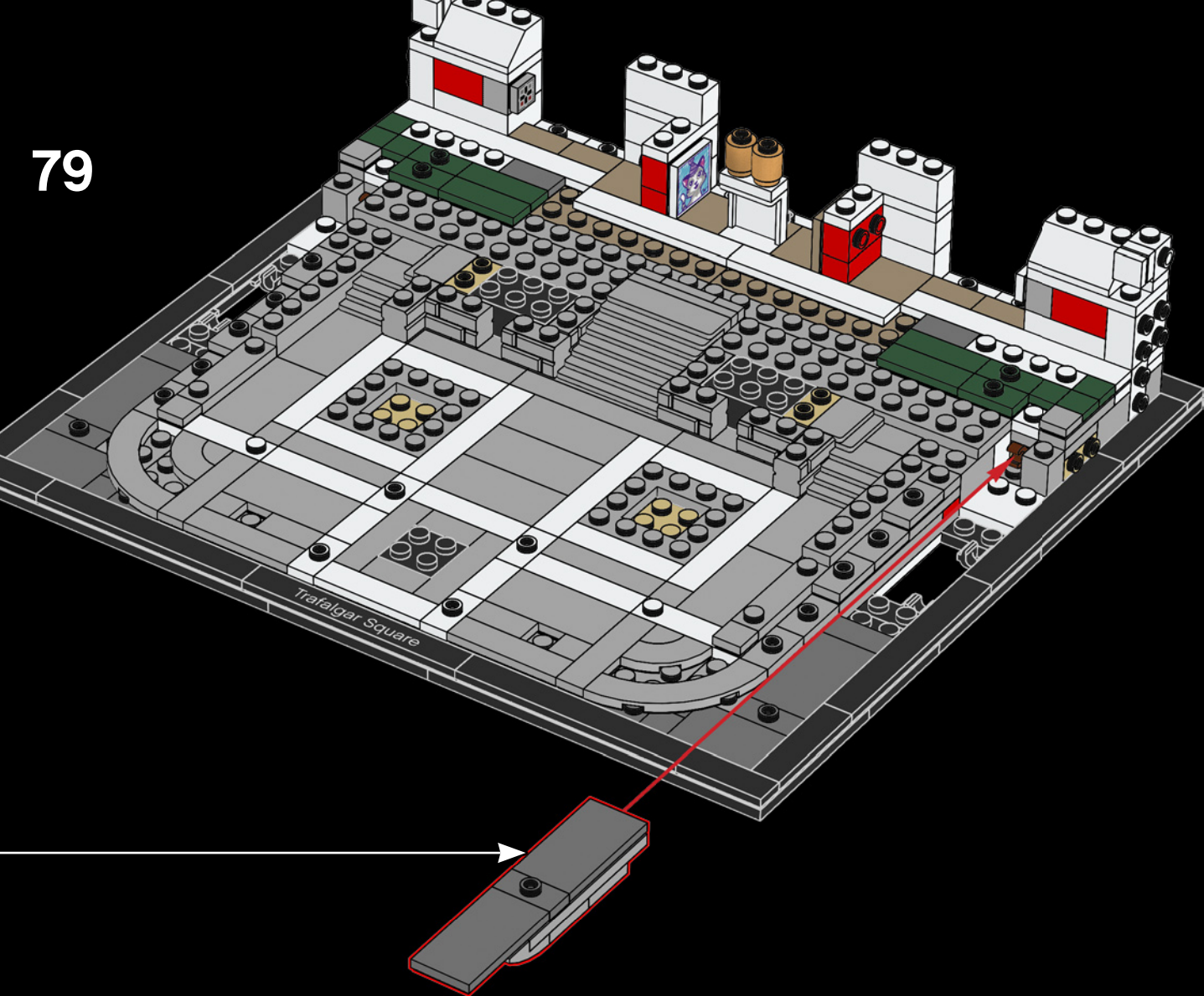

80



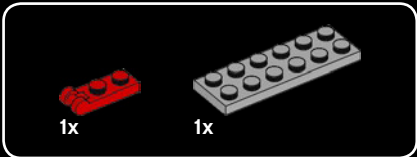
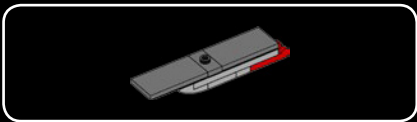

80

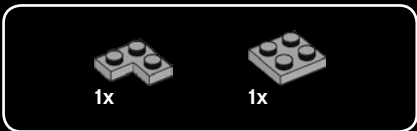
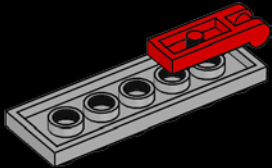

81

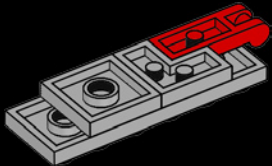

82

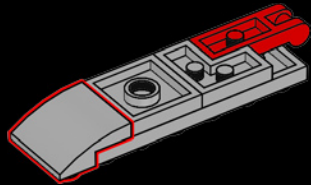

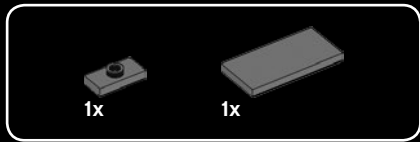

83

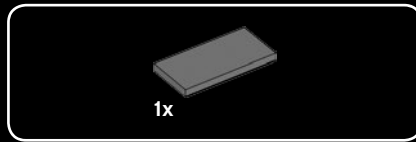
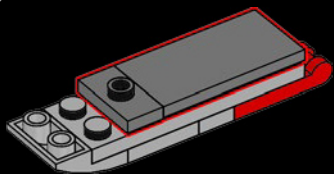

84

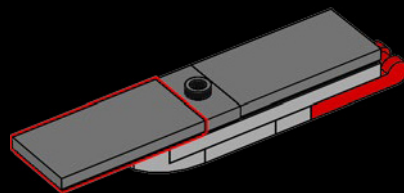

85

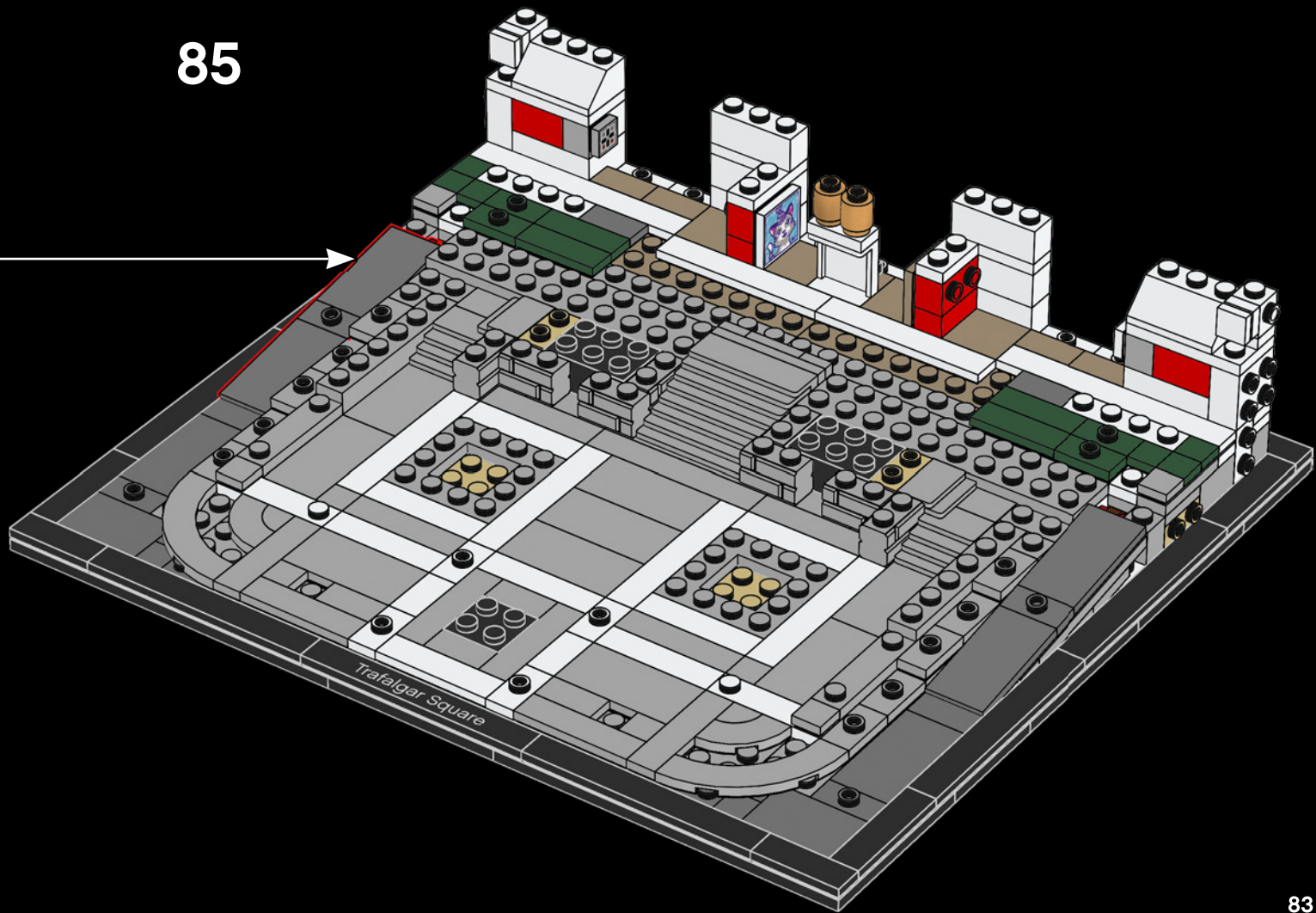



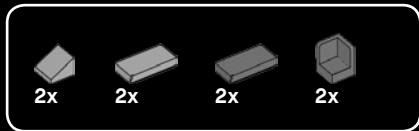

86

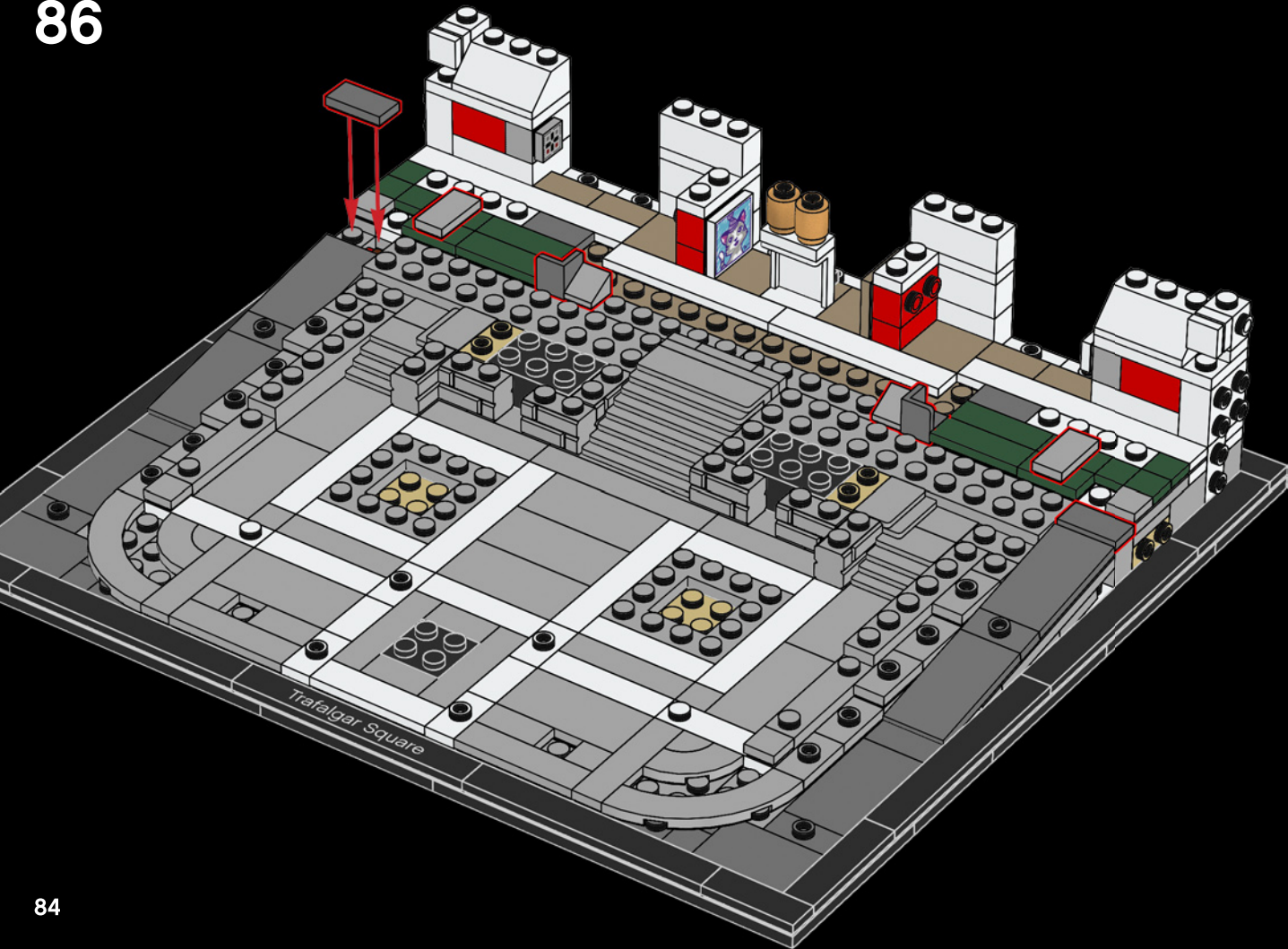



87

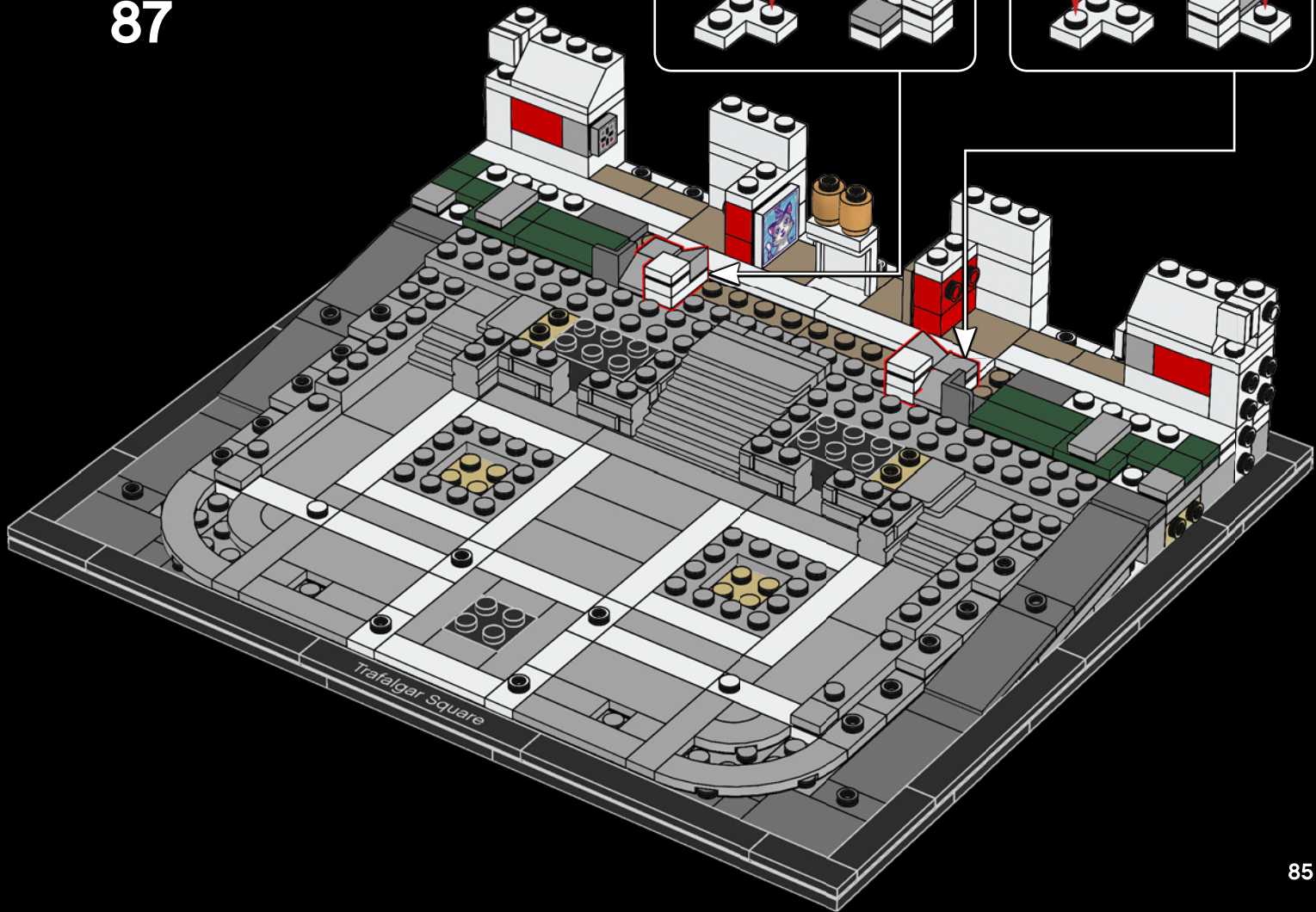
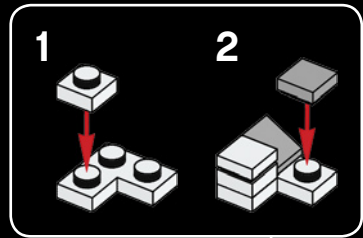
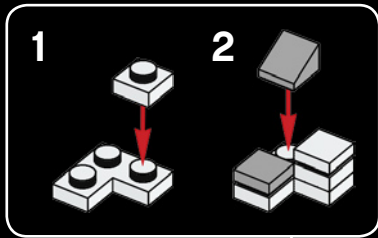

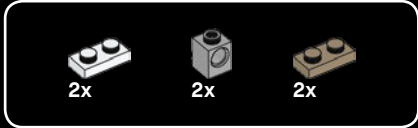

88

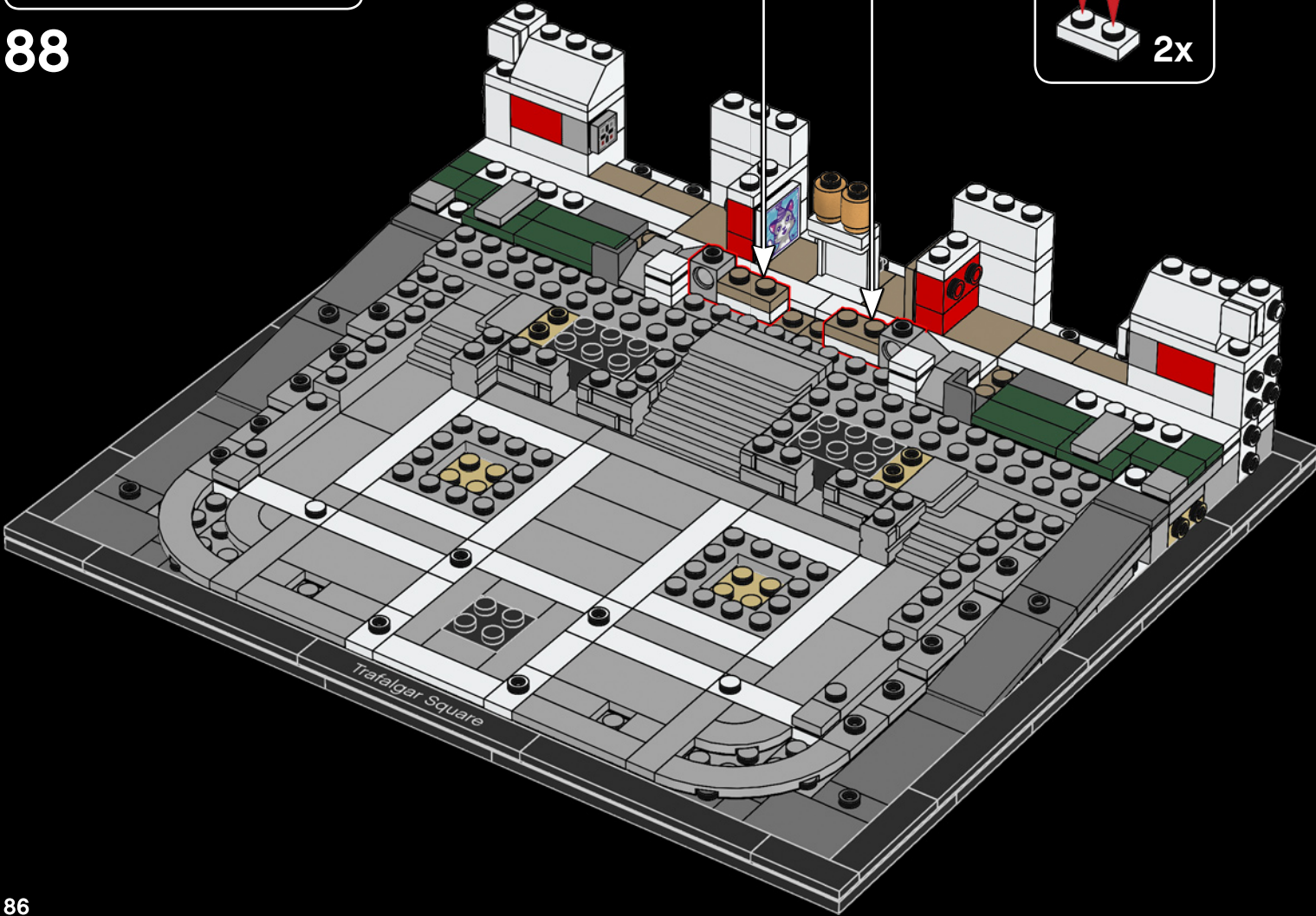
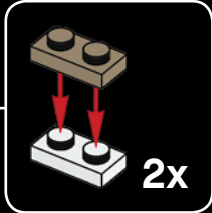



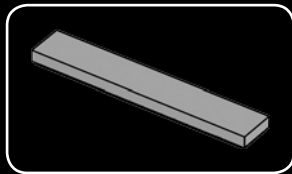
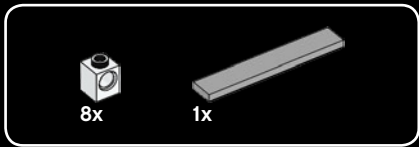

89

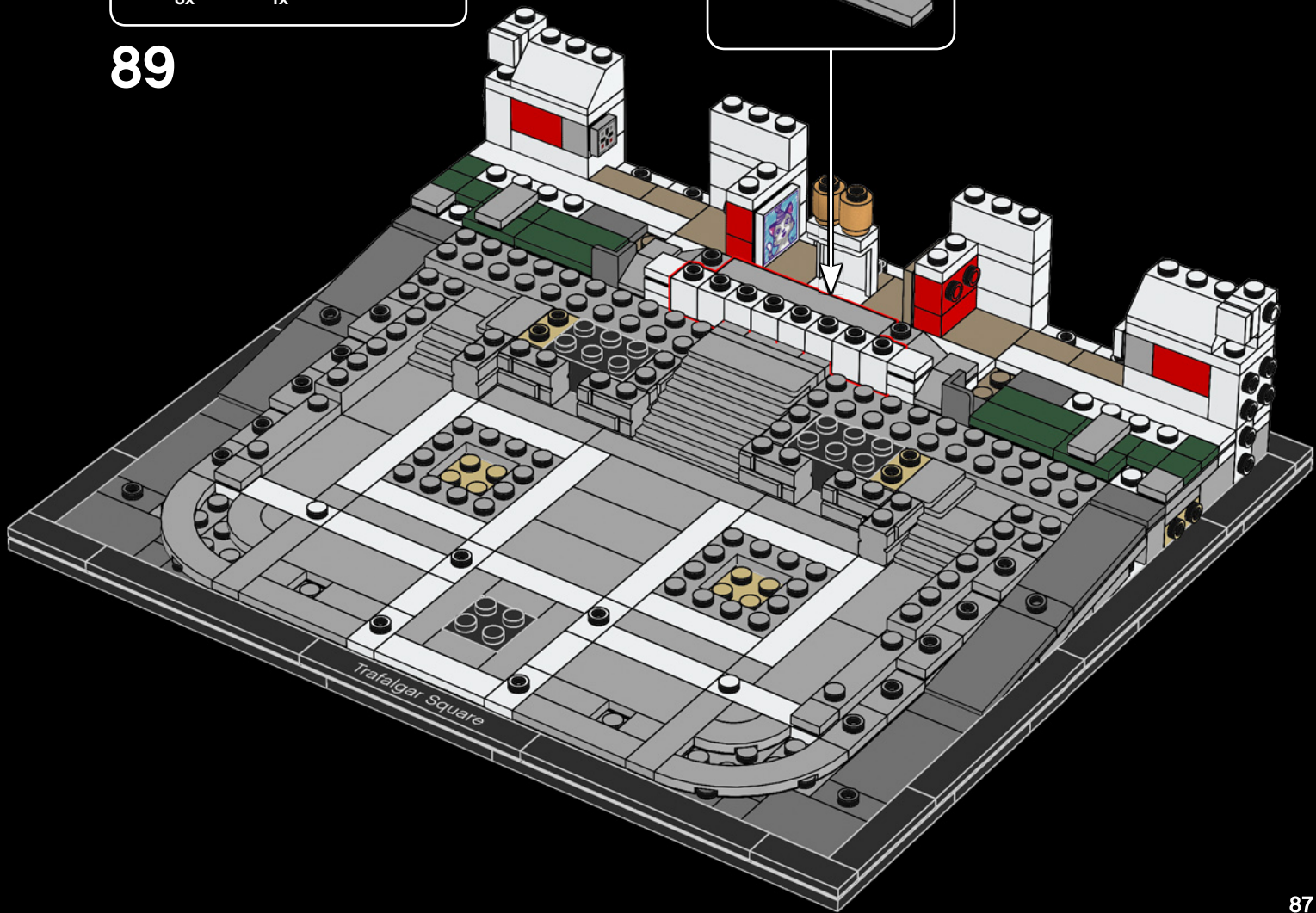



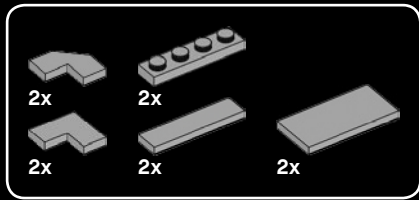

90

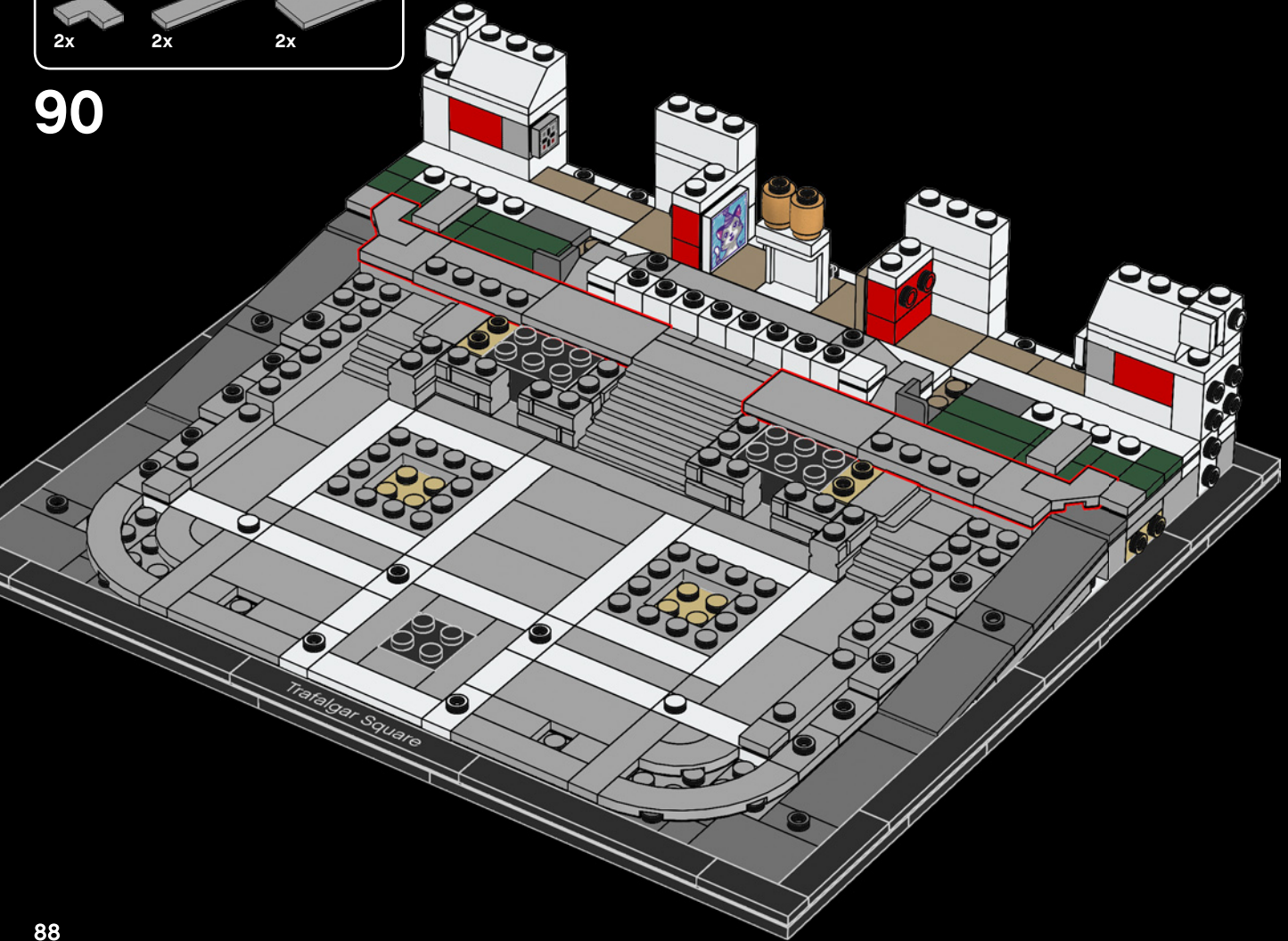



91

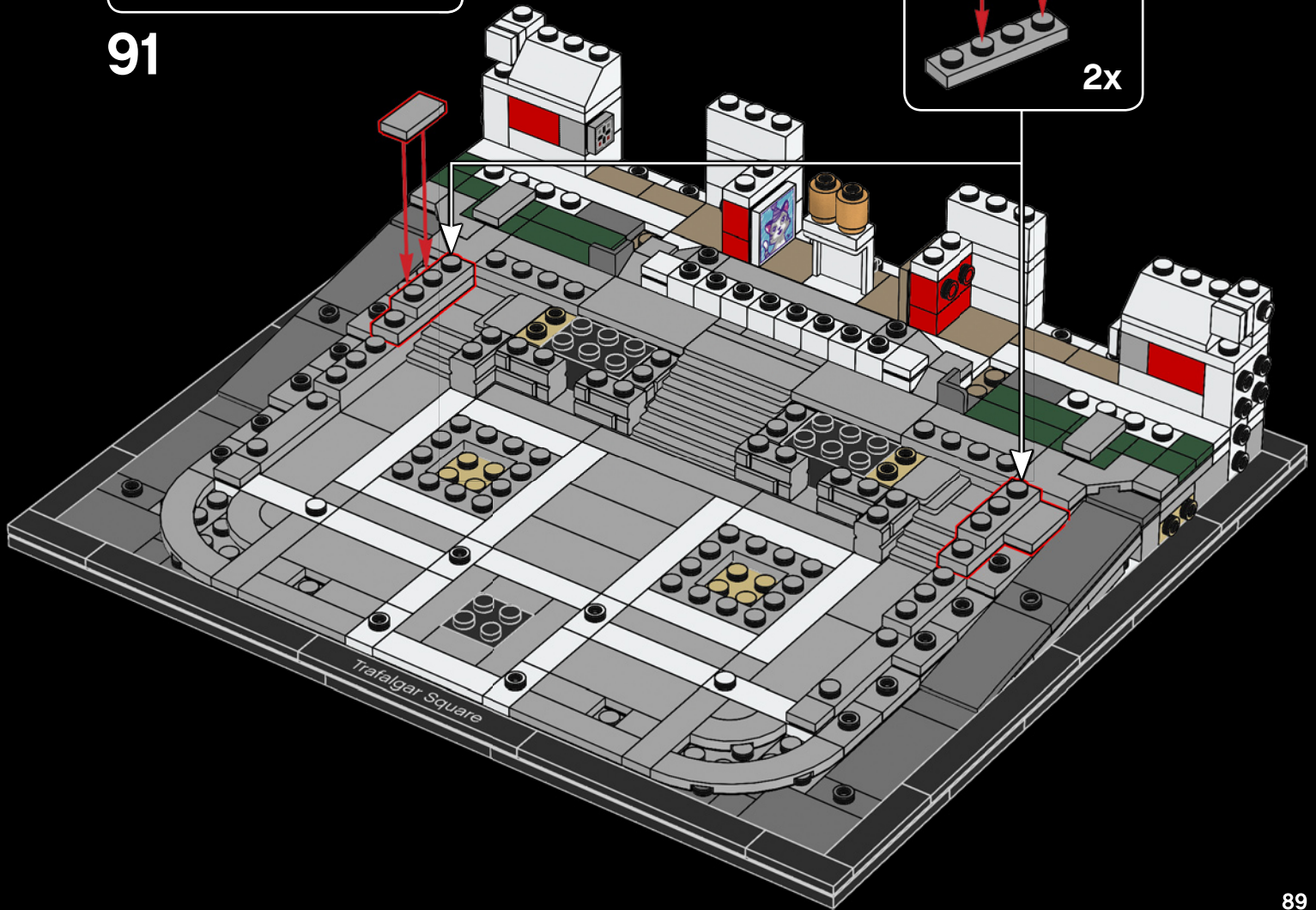
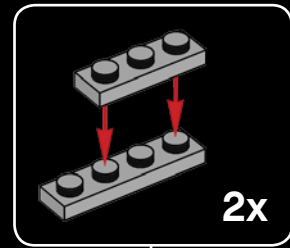

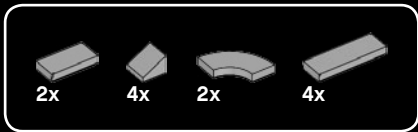

92

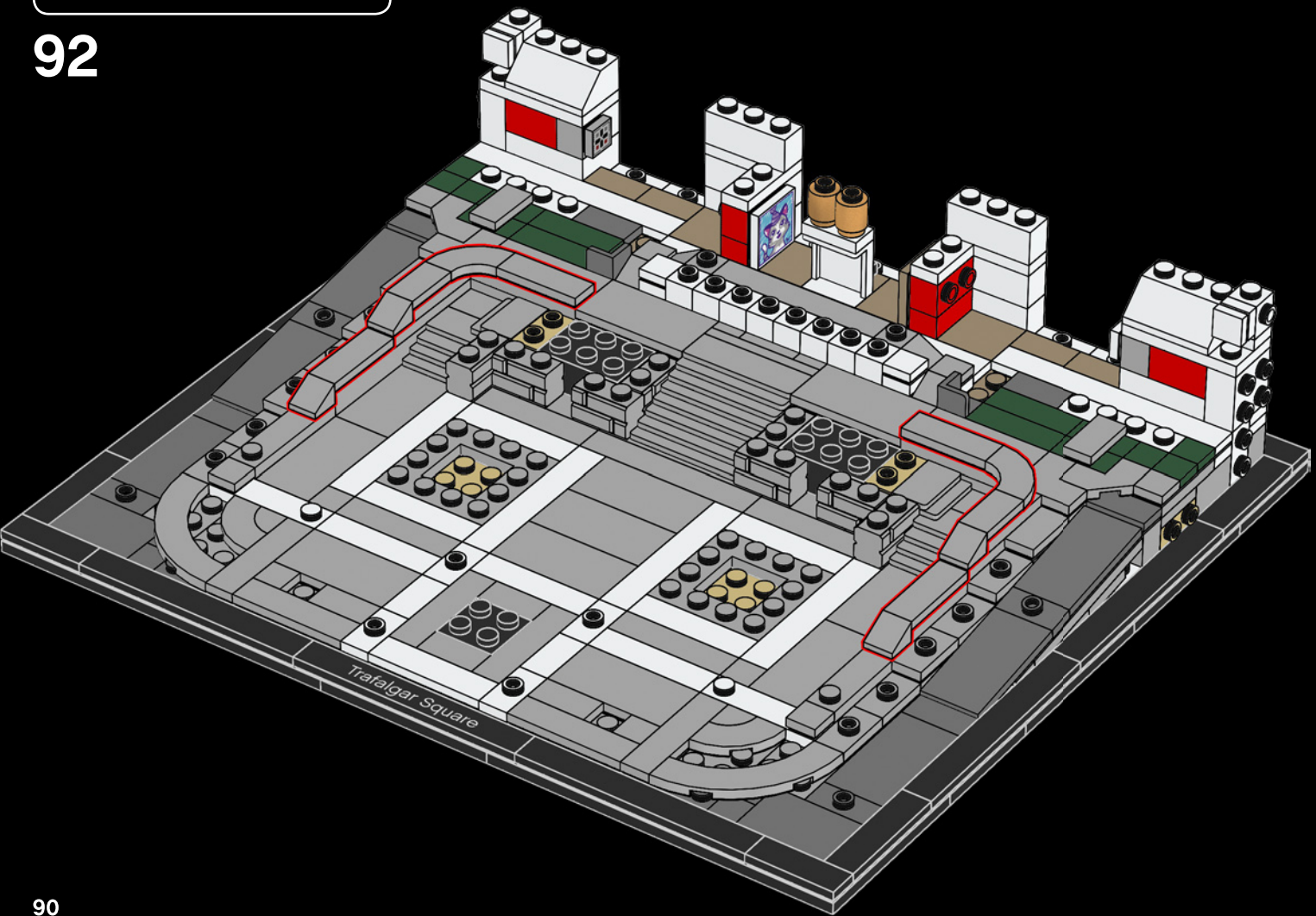



8x

8x

93

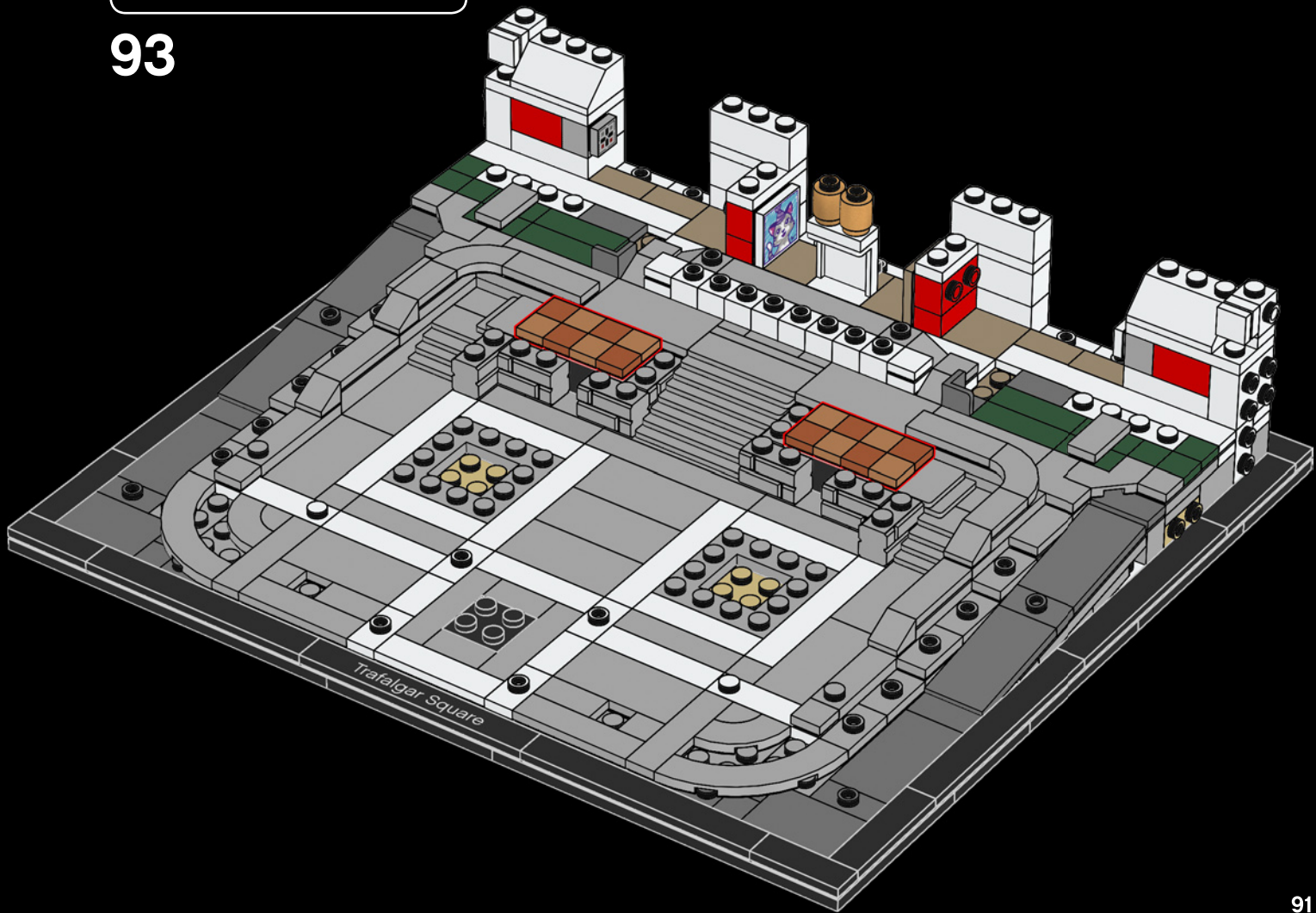

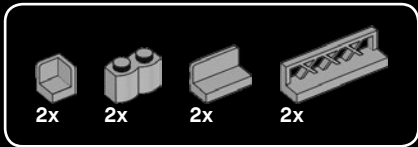

94

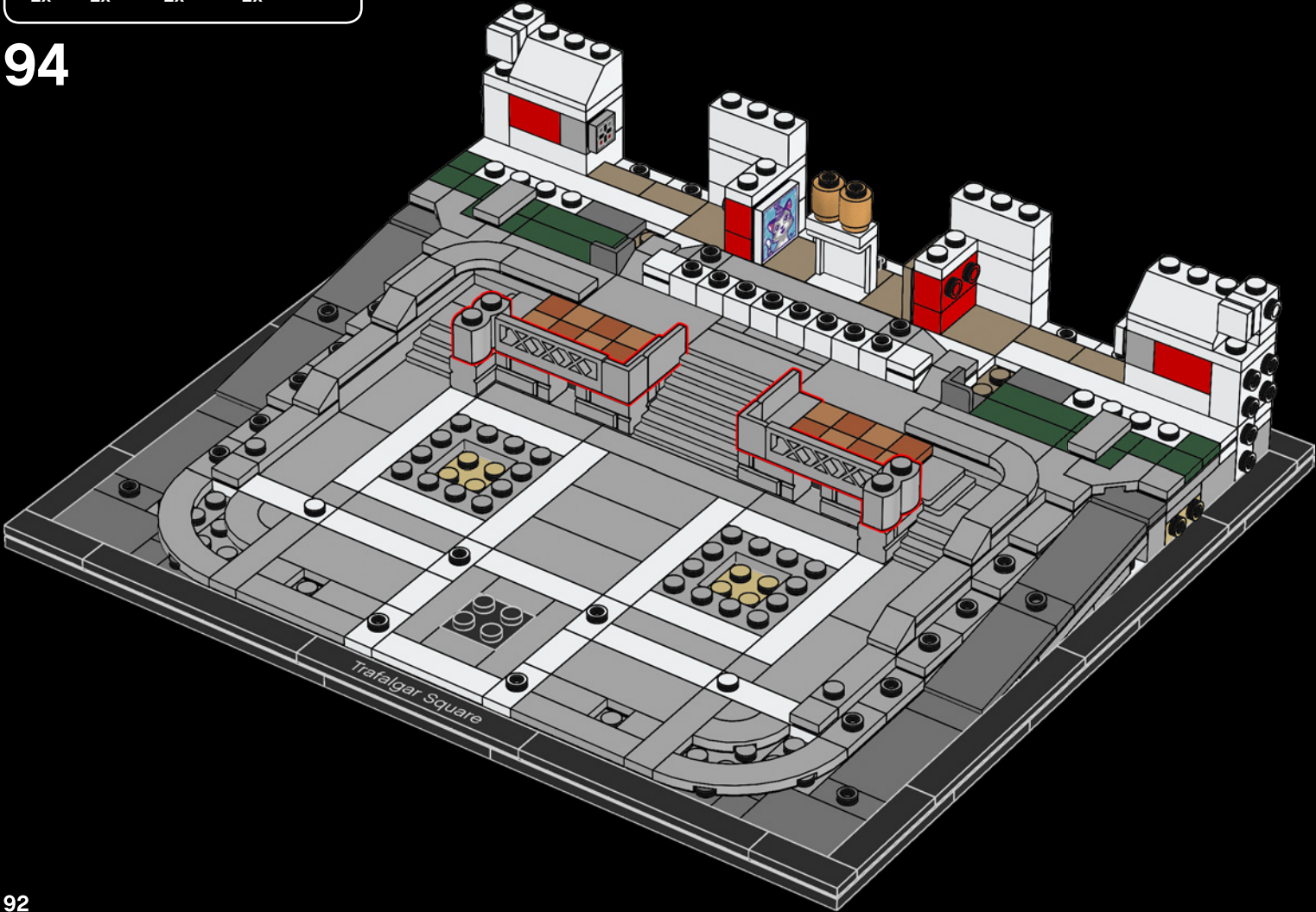

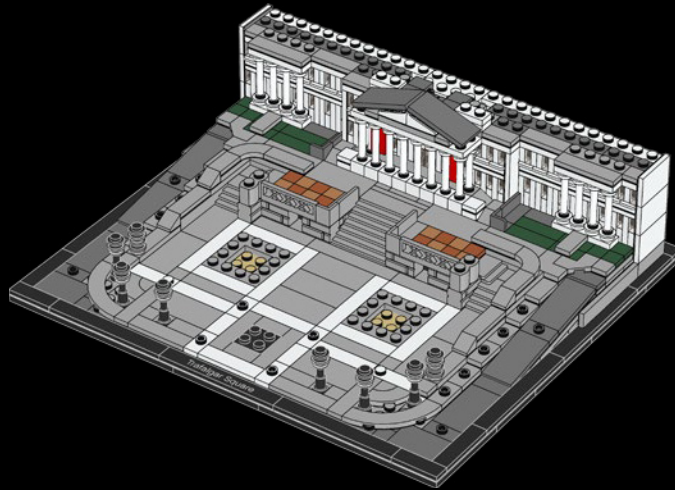





2x



2x



2x

95

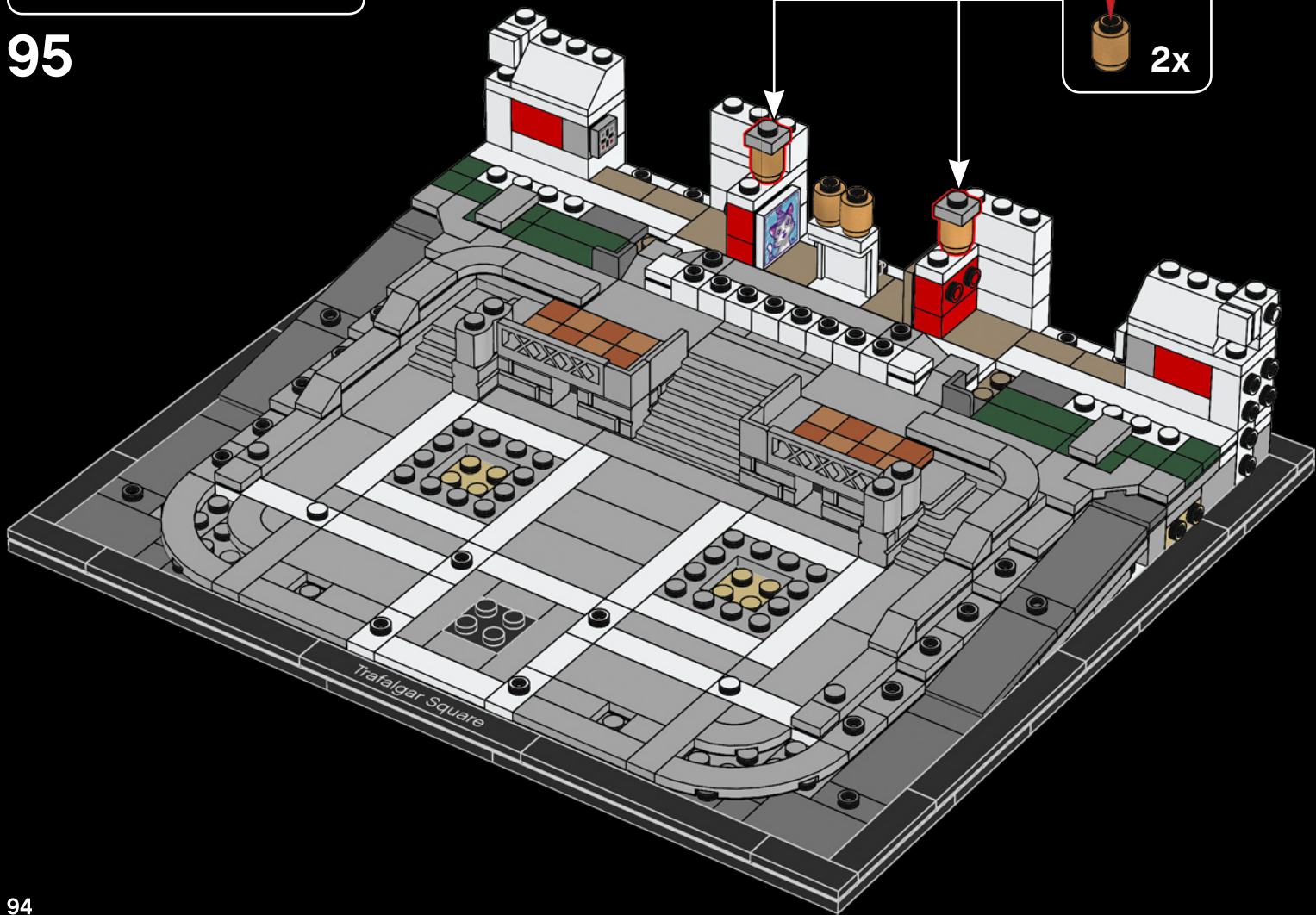

94

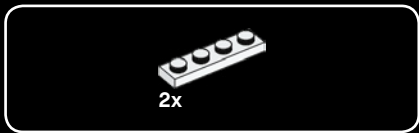
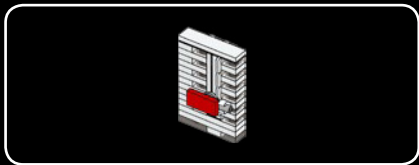

96

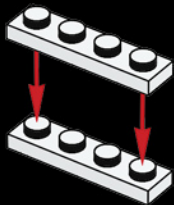

97

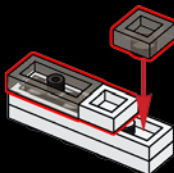

98

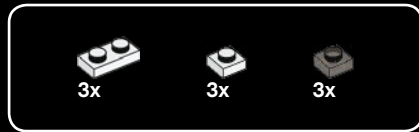
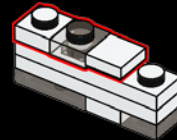

99

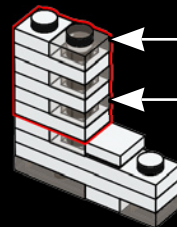
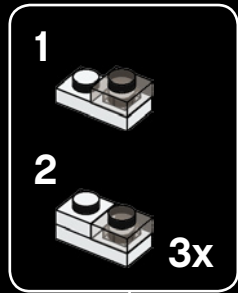



100

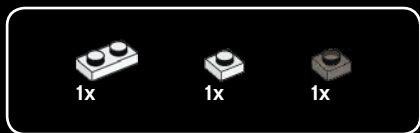
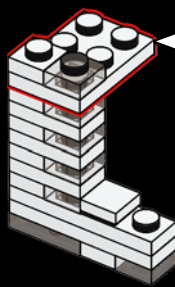
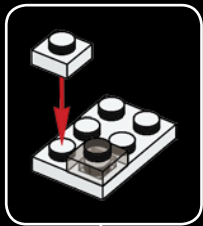

101

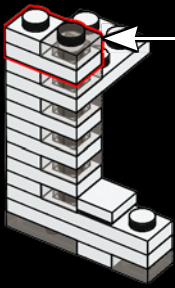
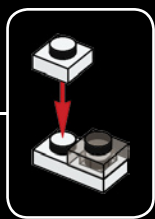

102

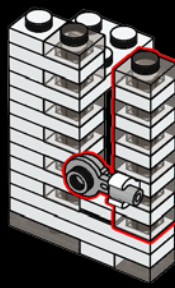
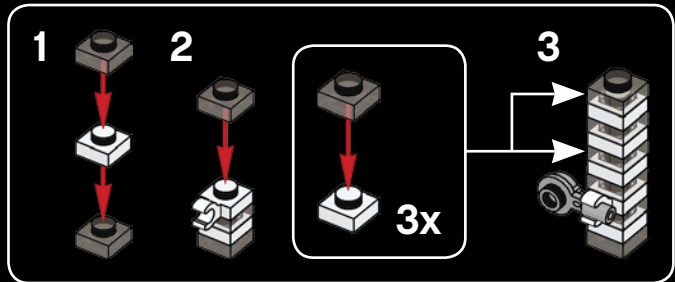



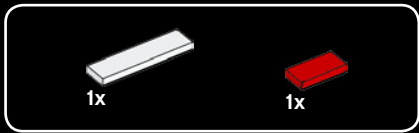

103

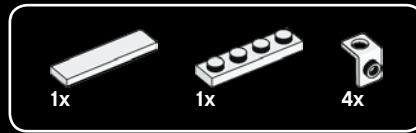
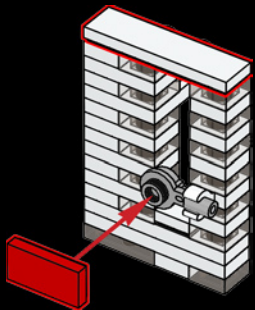

104

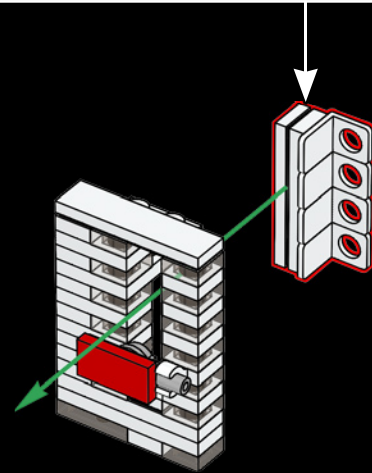
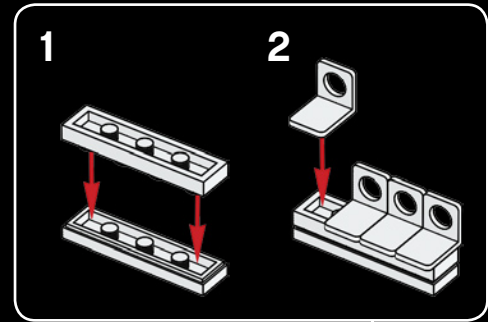

105

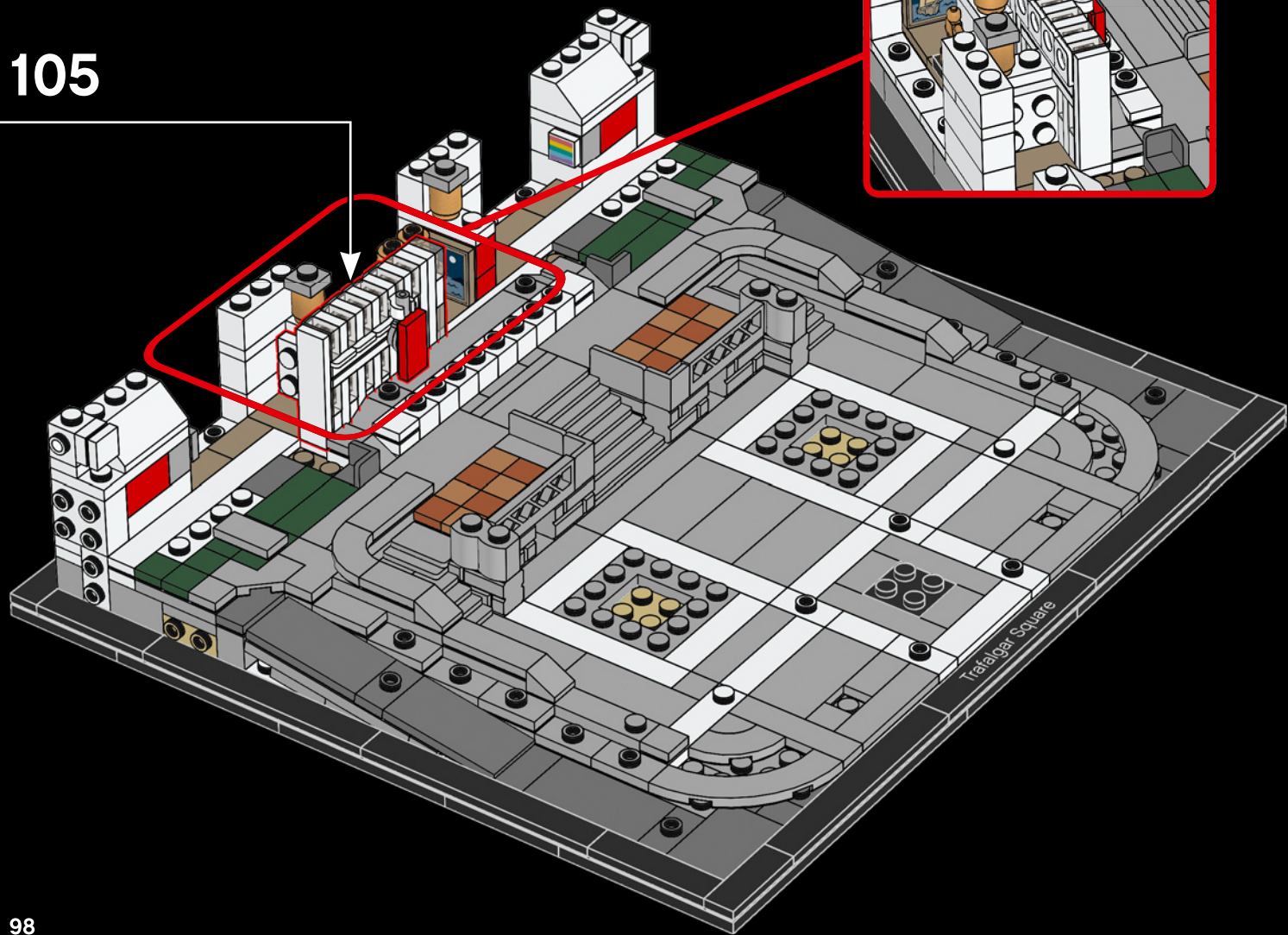

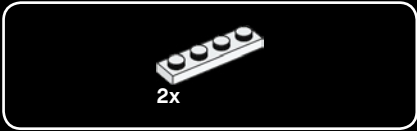
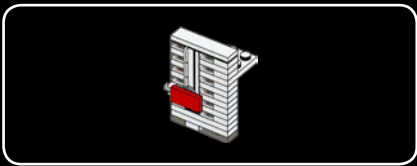

2x

# 106

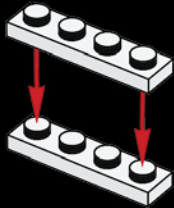

# 107

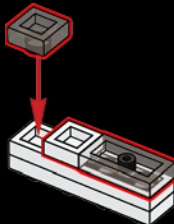

# 108

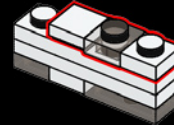
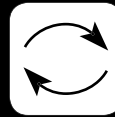

# 109

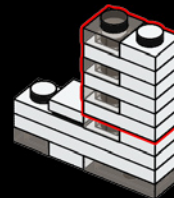
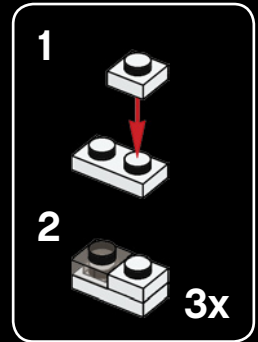

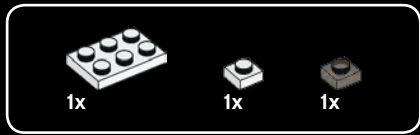

110

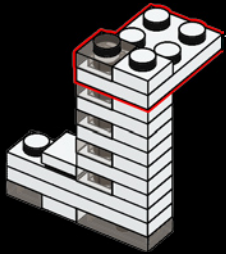
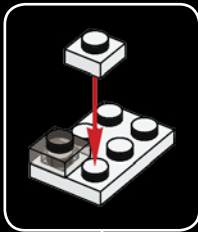

111

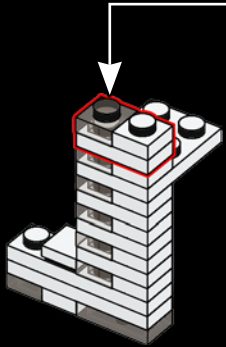
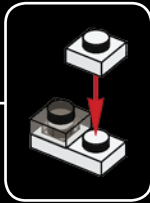

112

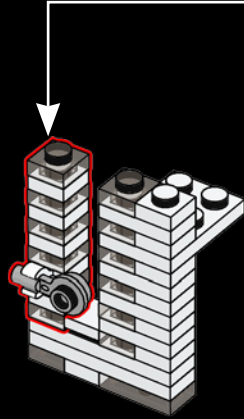
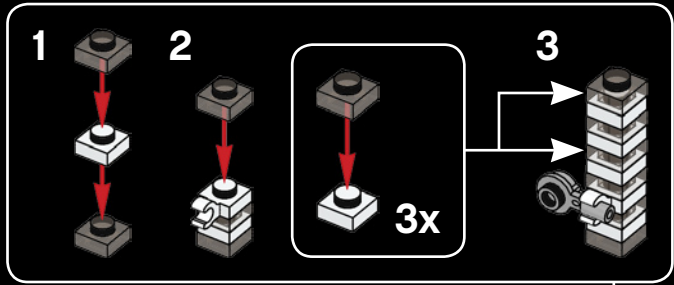



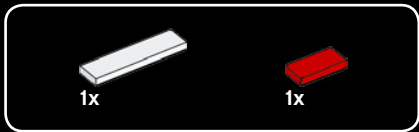

113

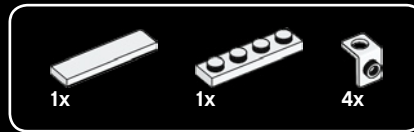
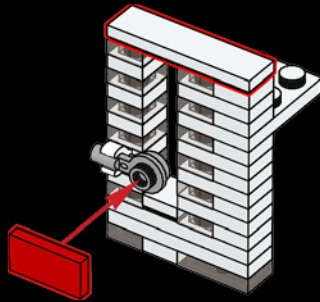

114

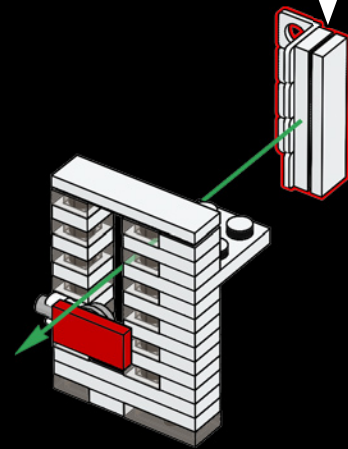
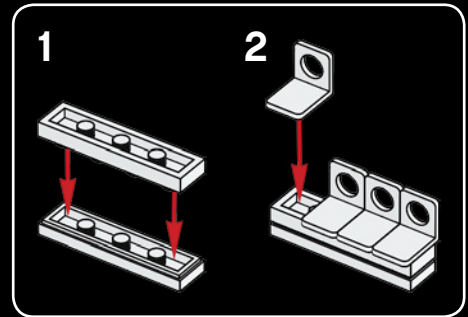

115

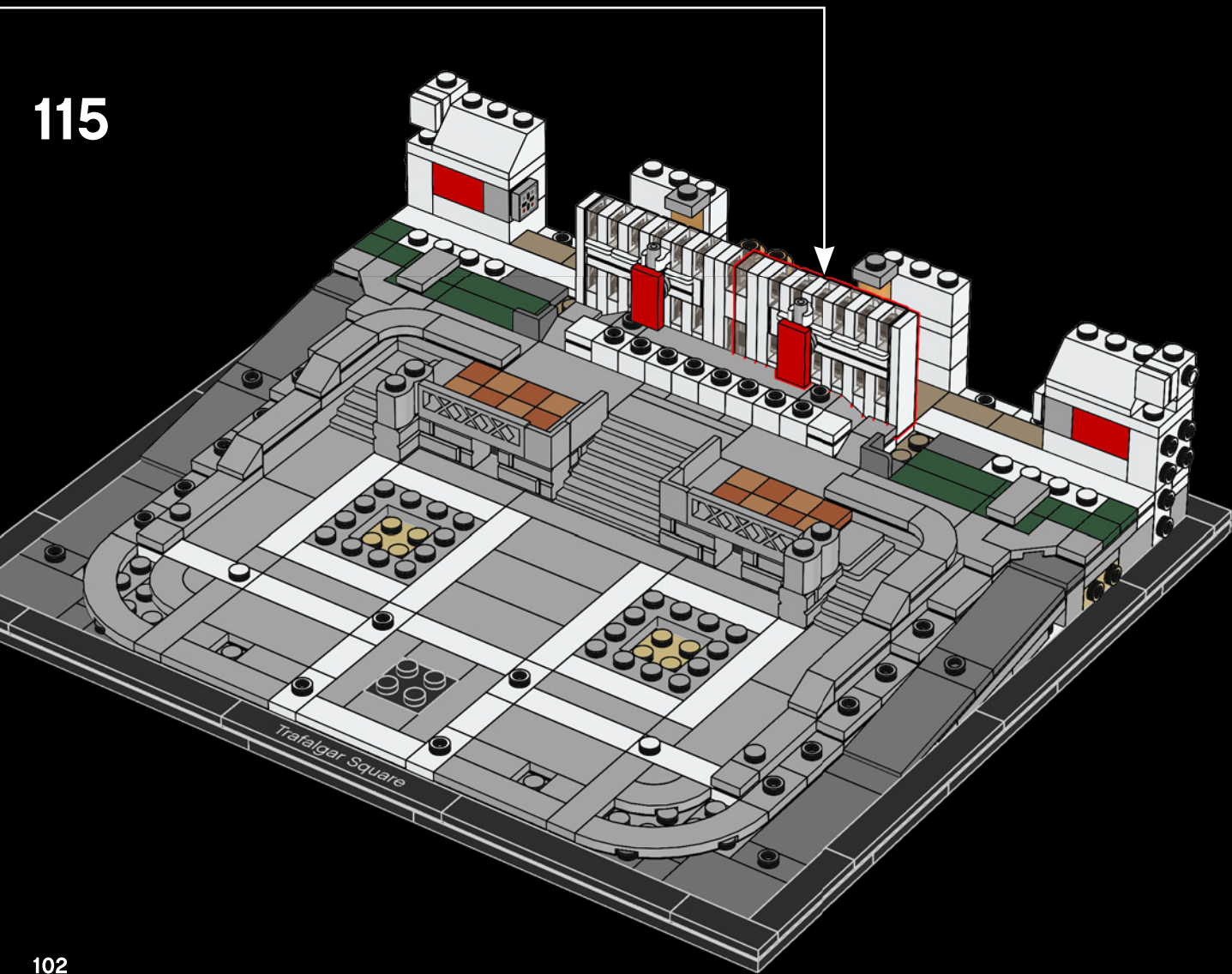



116

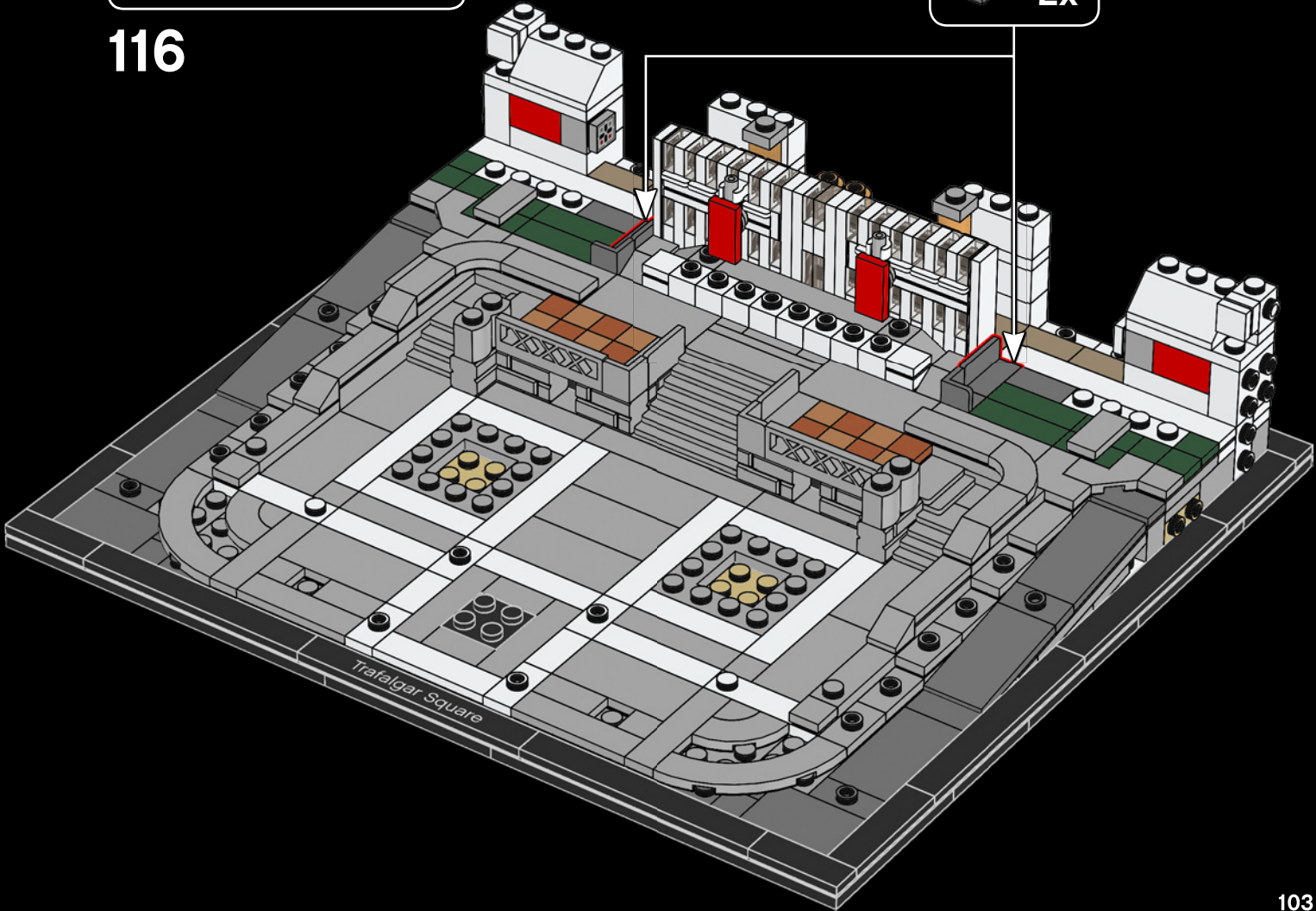
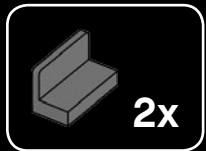

Trafalgar Square

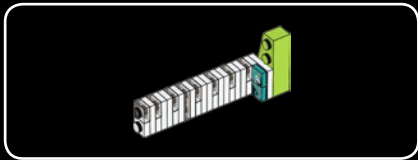

117

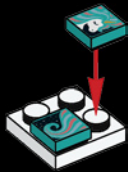

118

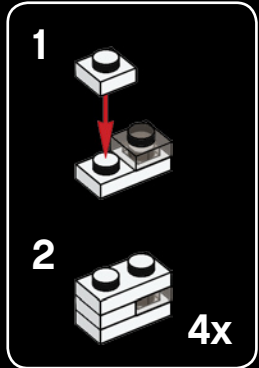





119

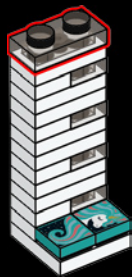

120

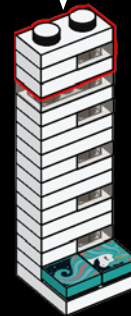
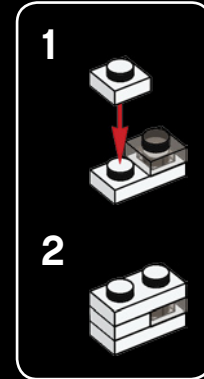



# 121

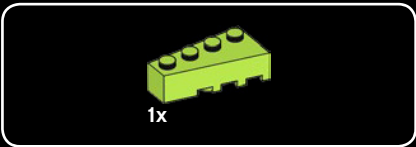
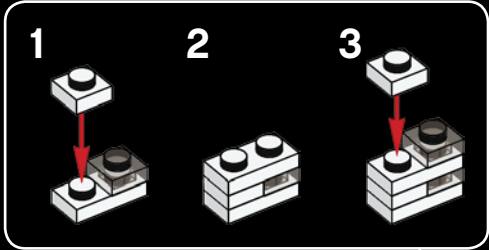

# 122

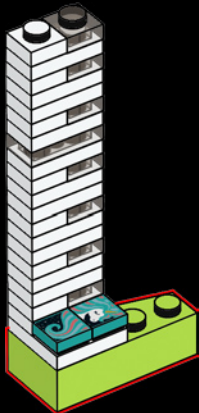

123

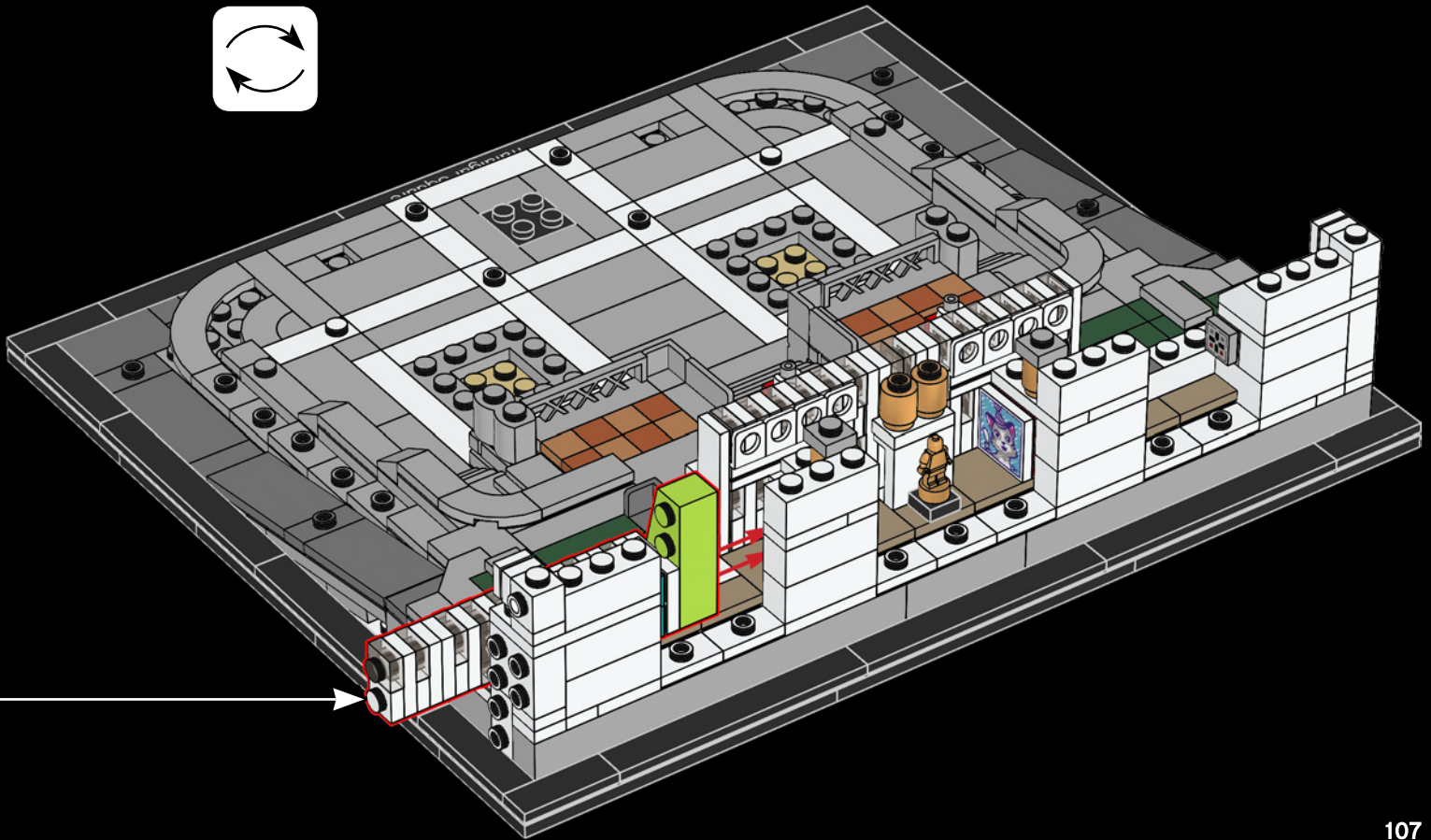

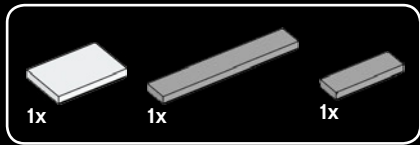

124

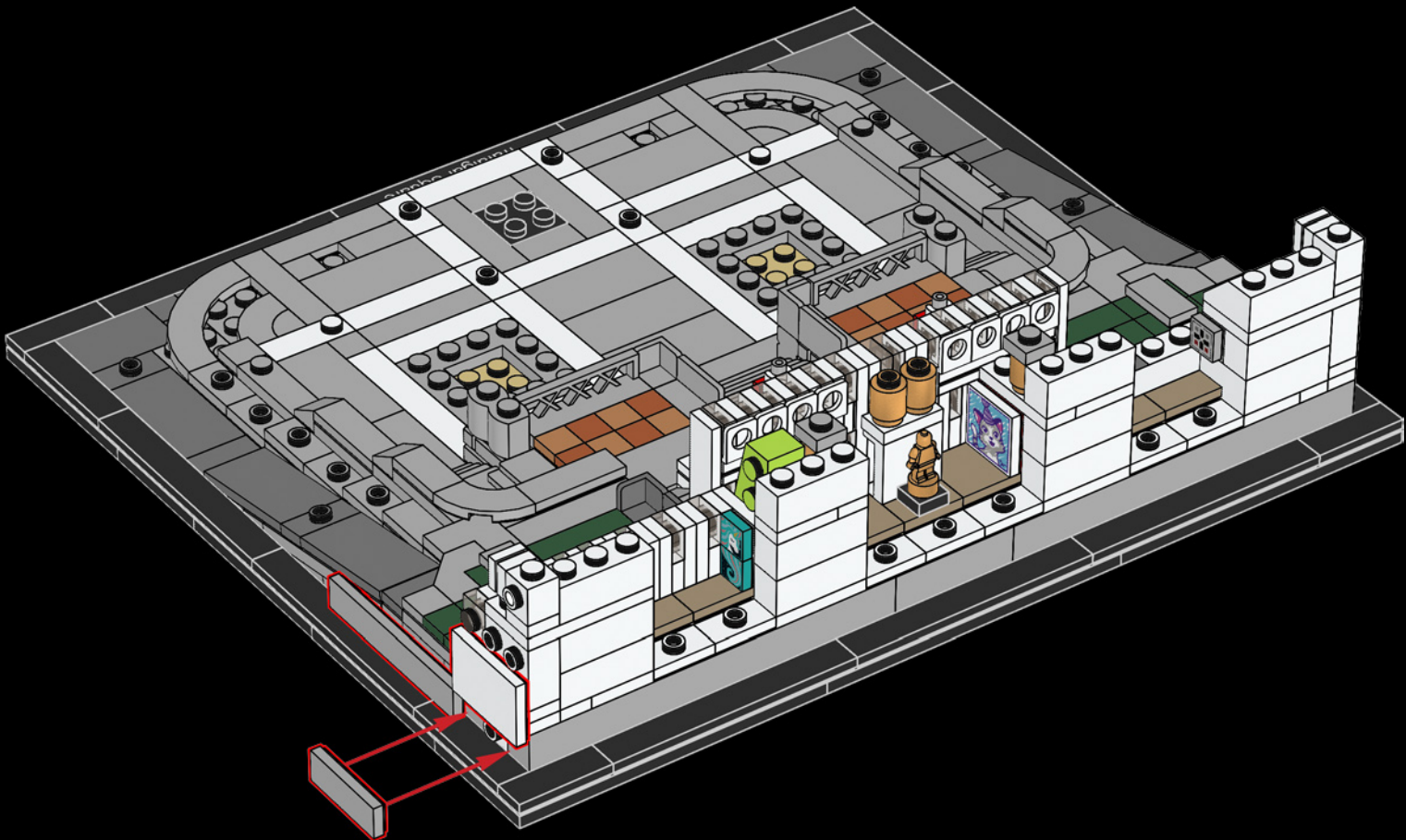



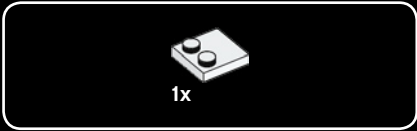
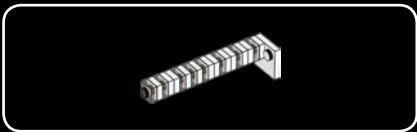

125



126

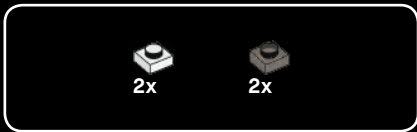
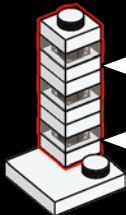
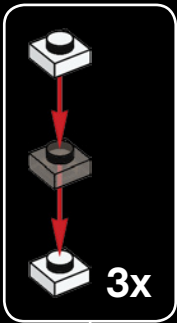

127

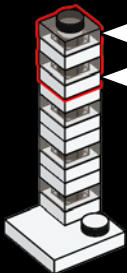
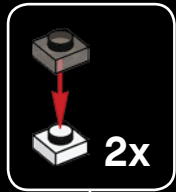



2x



1x

128

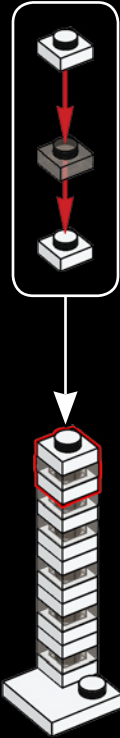

2x



2x

129

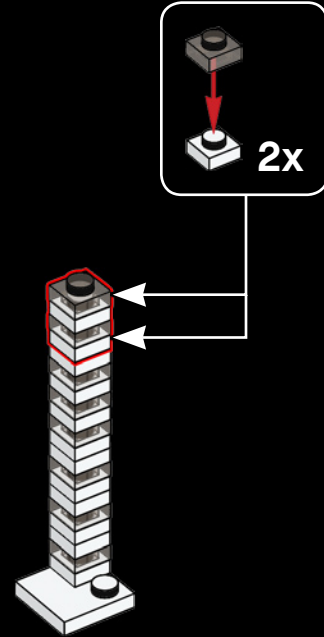

130

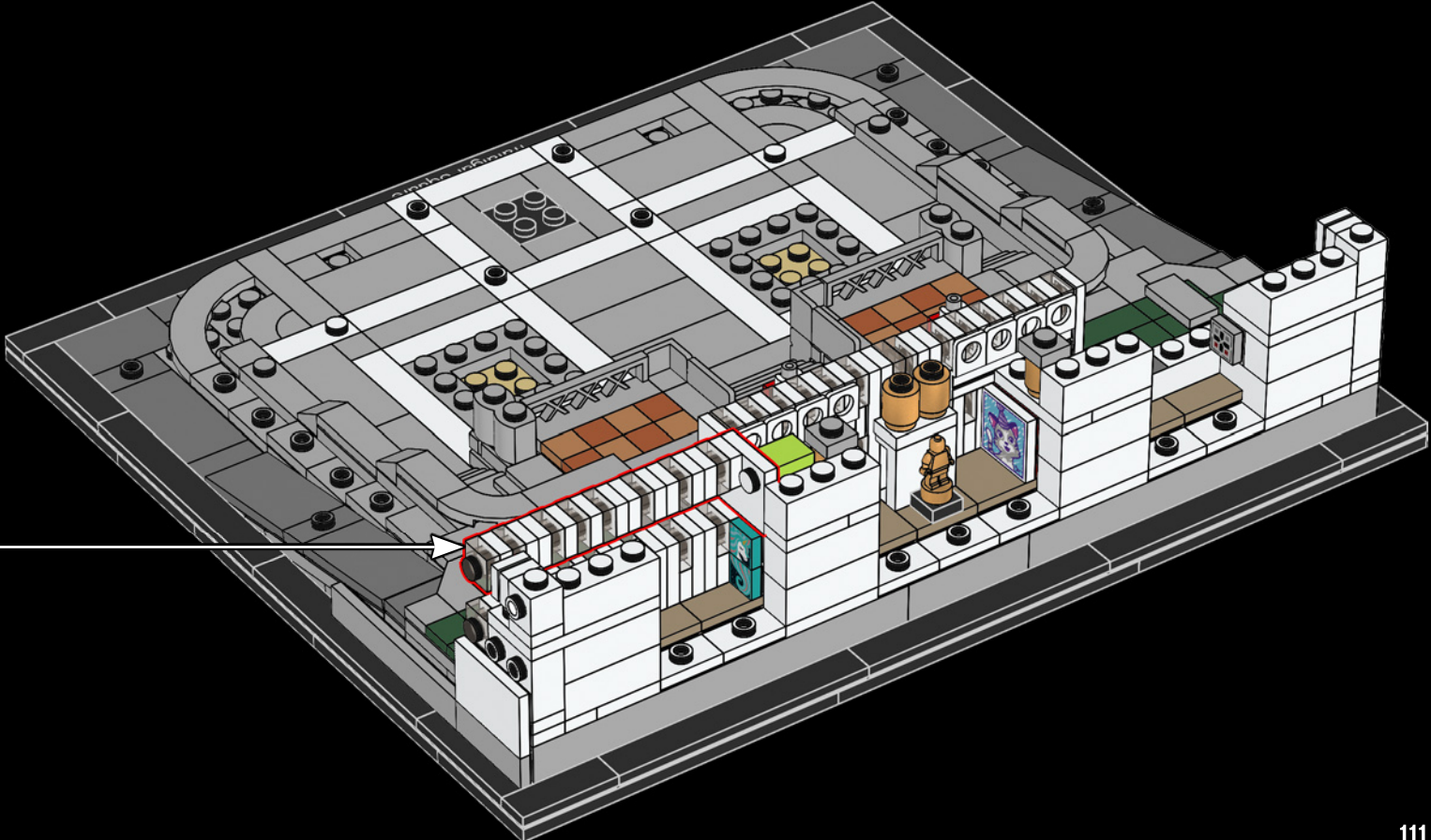

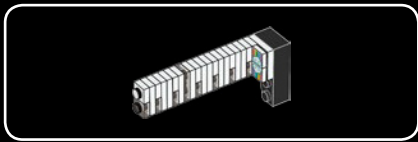

131



132

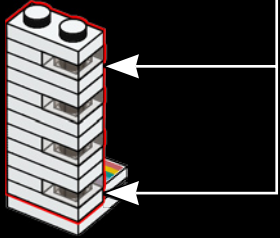
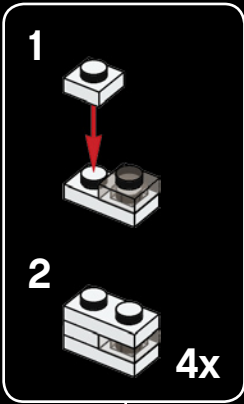





133



134

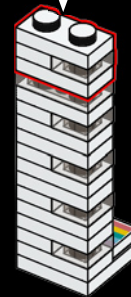
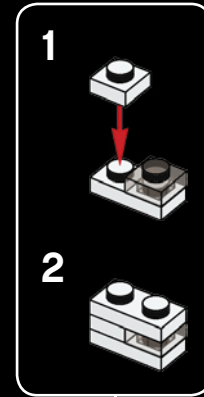



# 135

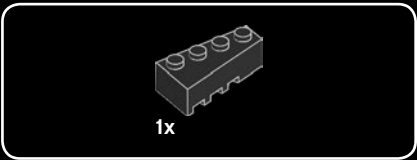
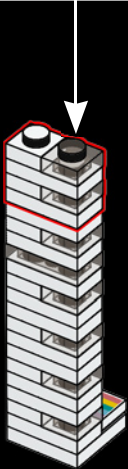
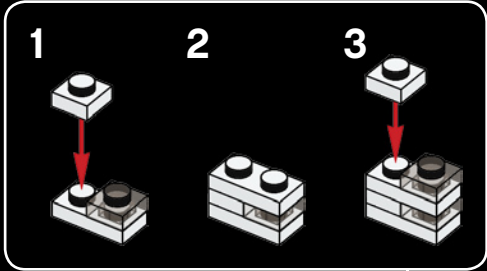

# 136



137

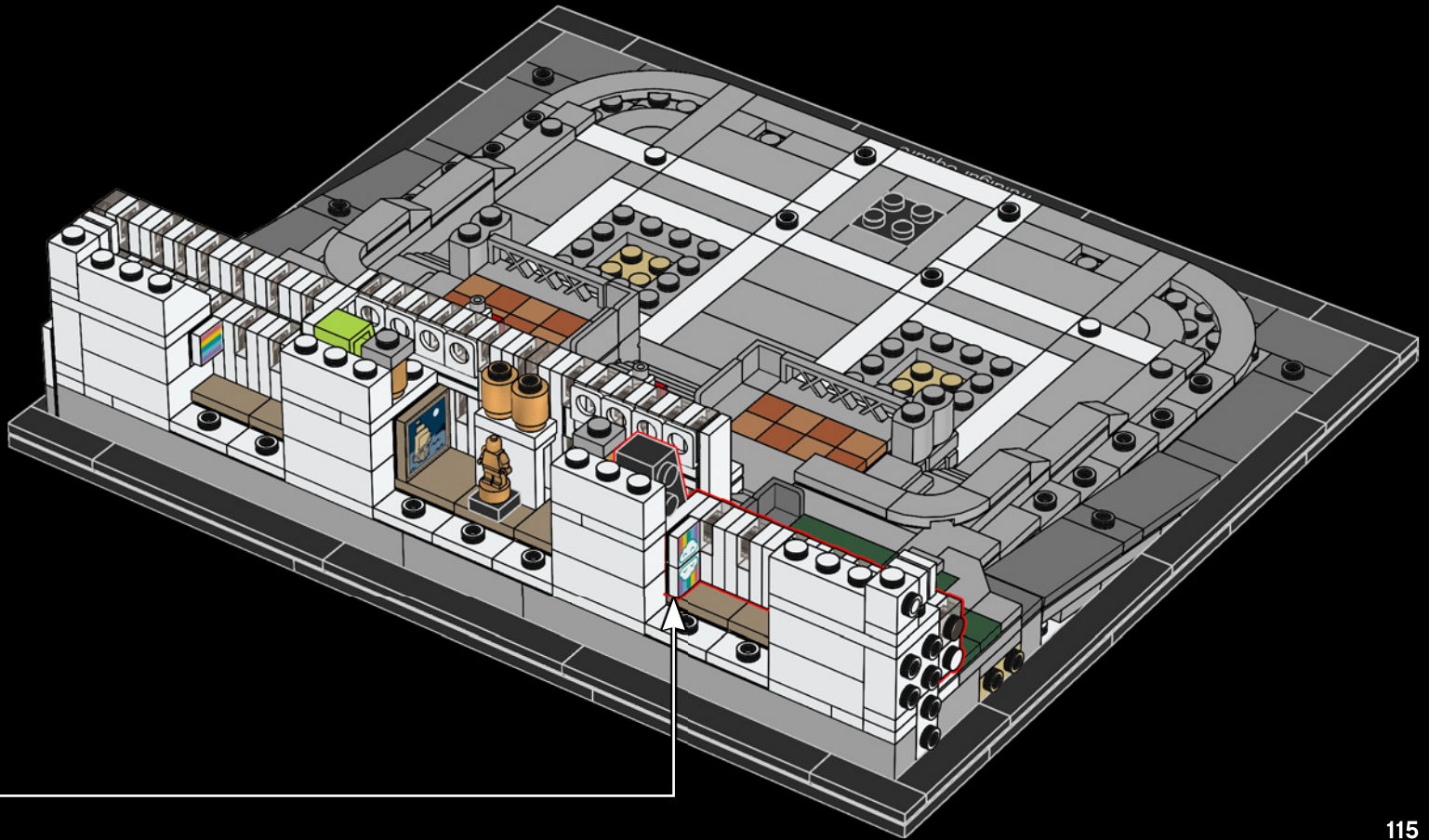

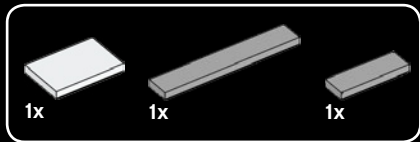

138

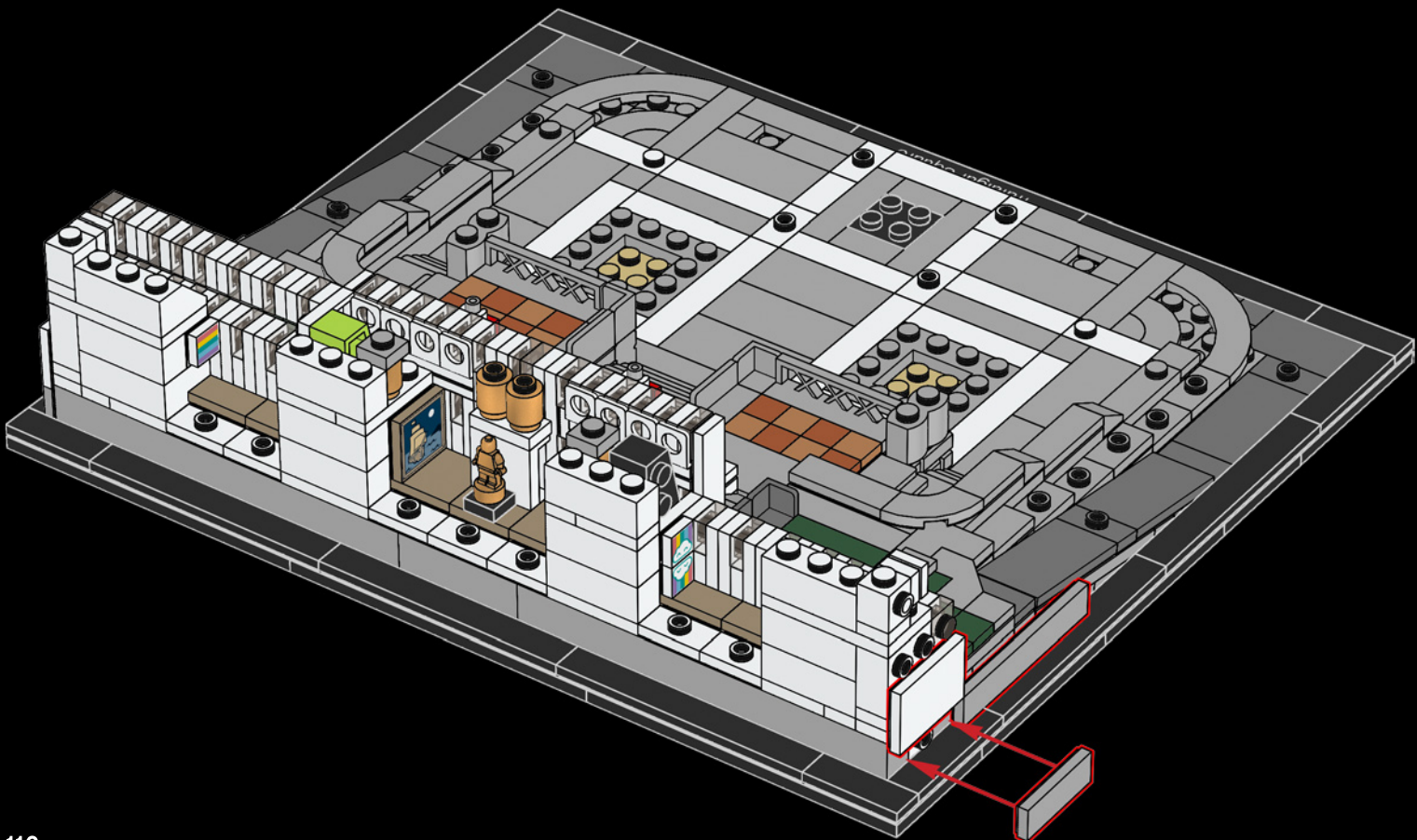



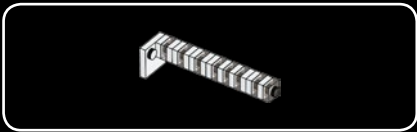

139



140

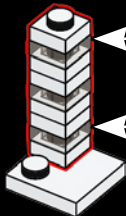
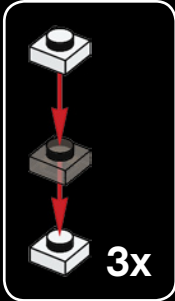

141

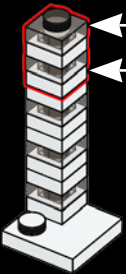
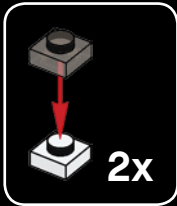



2x



1x

142

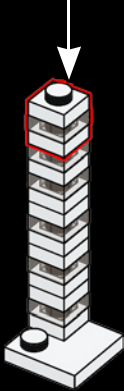
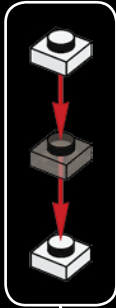

2x



2x

143

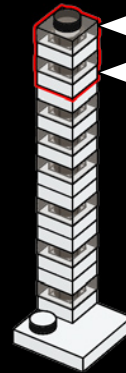
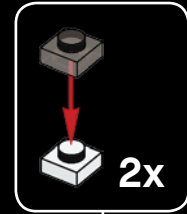

144

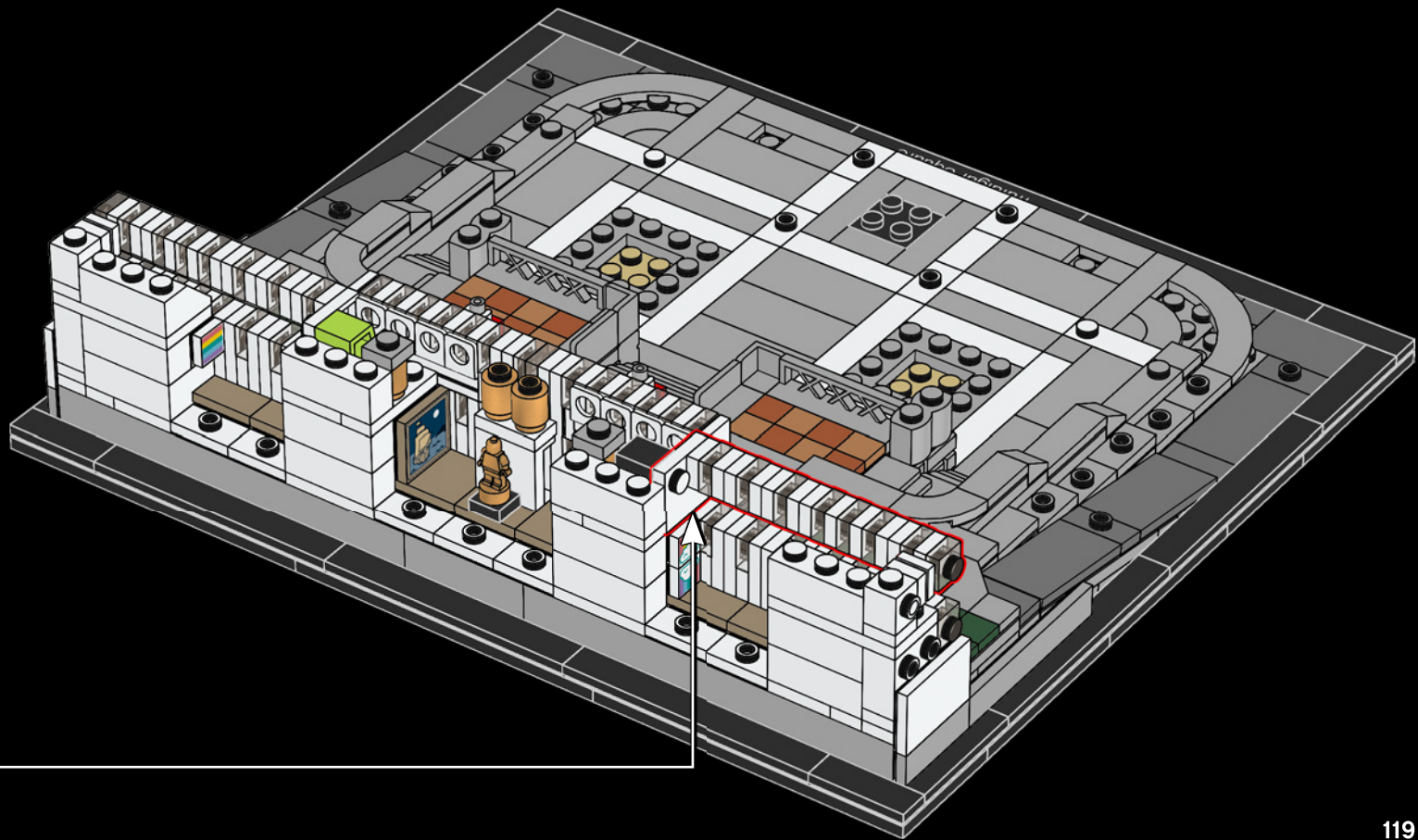

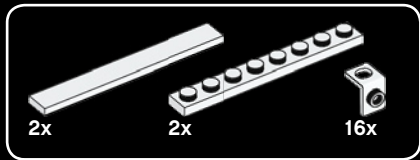

145

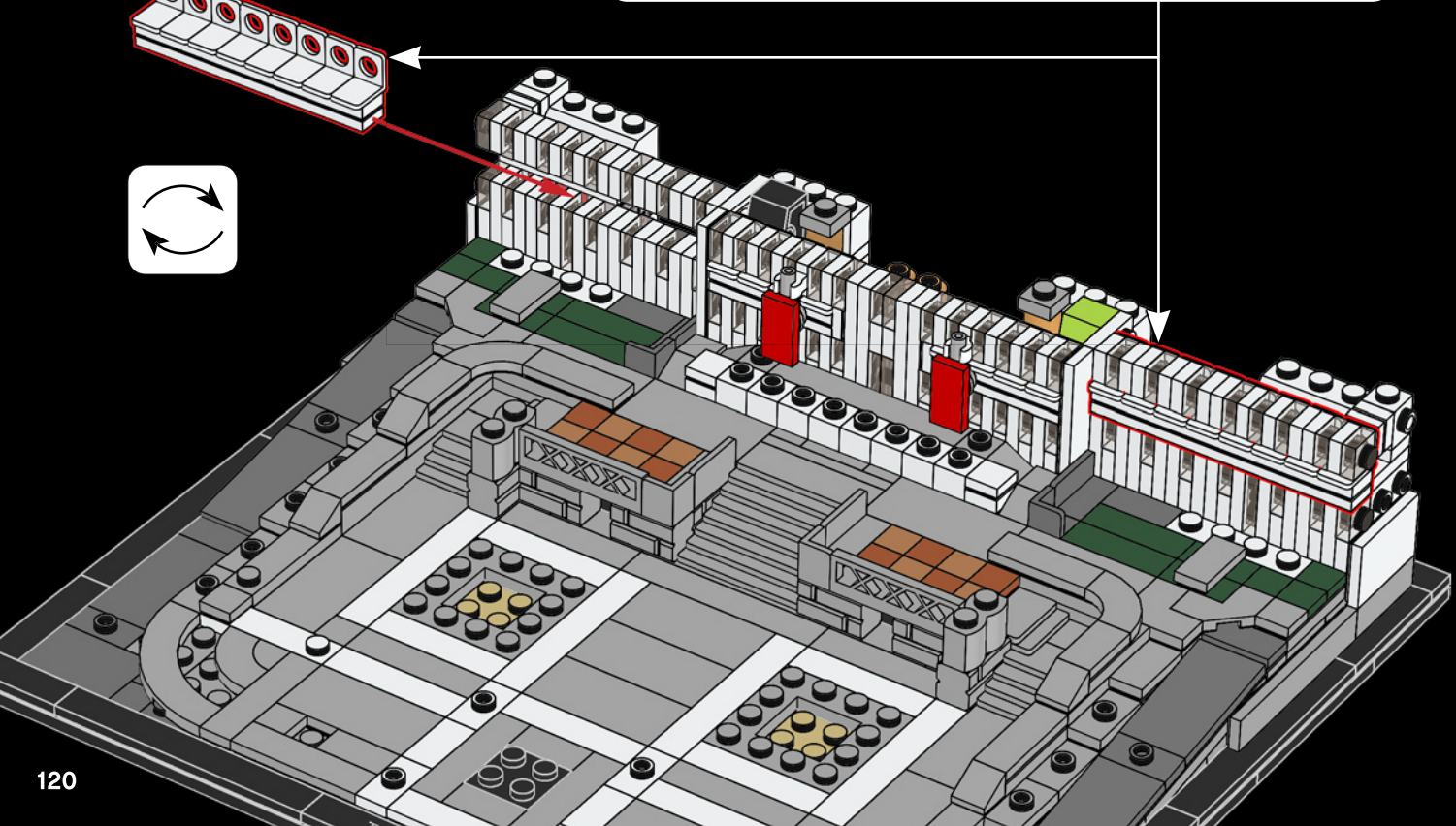
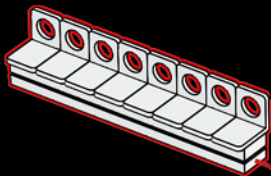
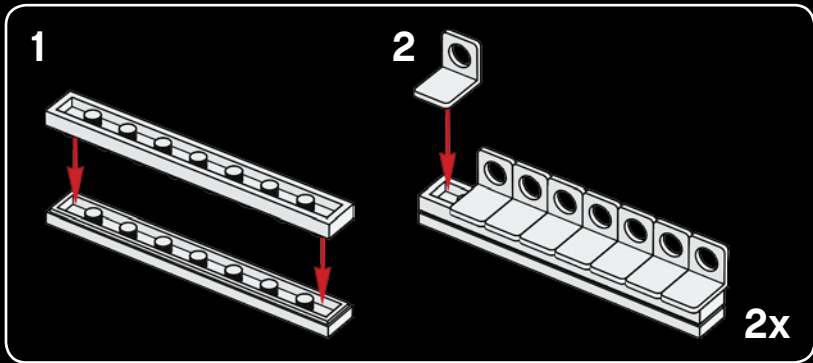





146

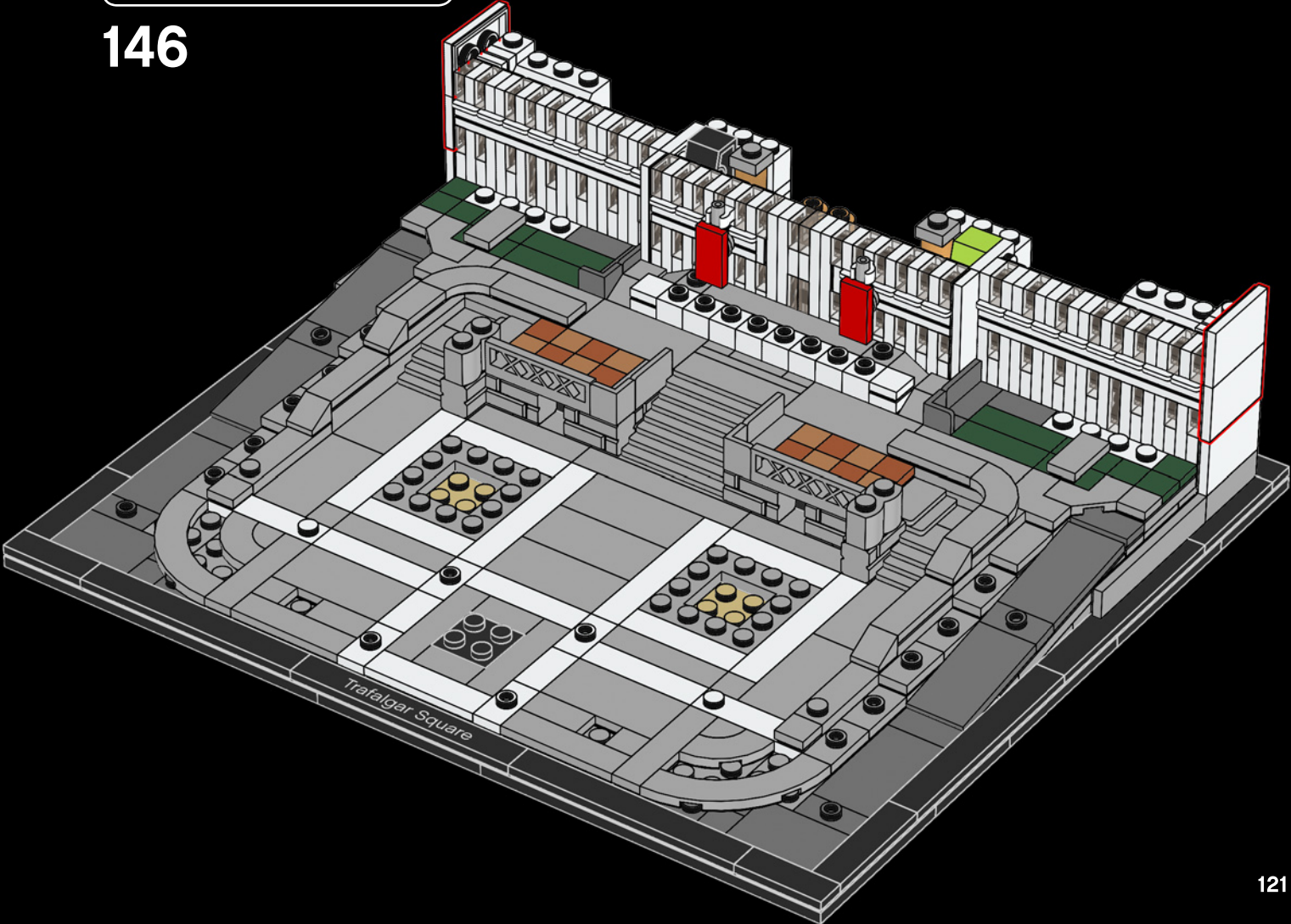

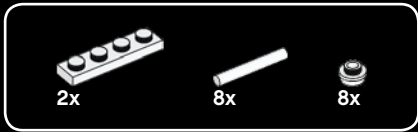

147

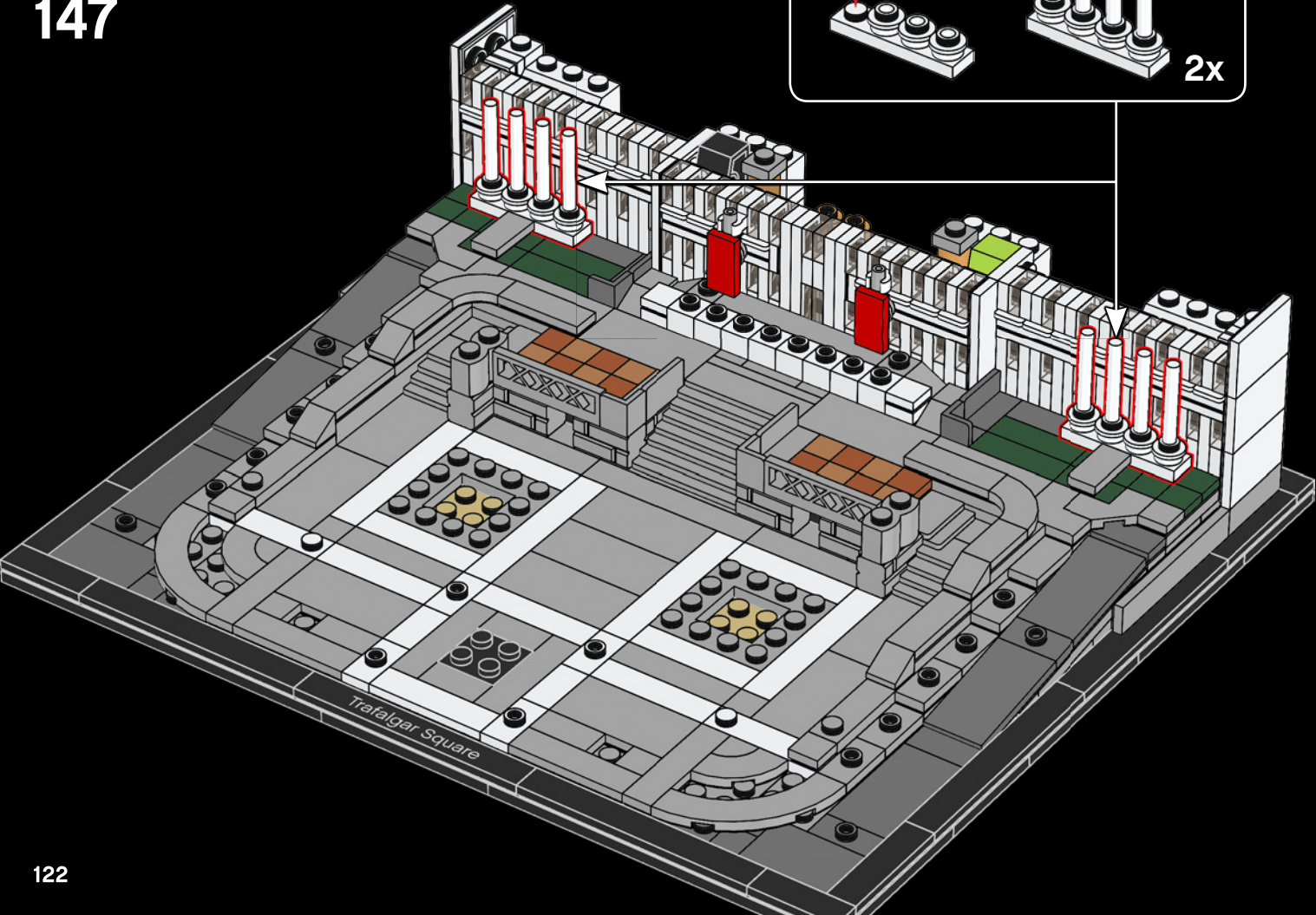
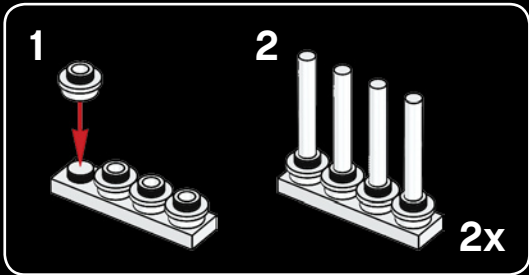

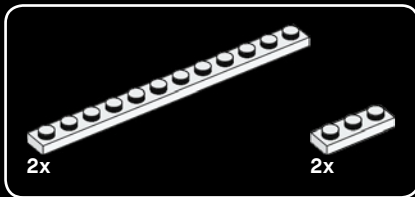

148

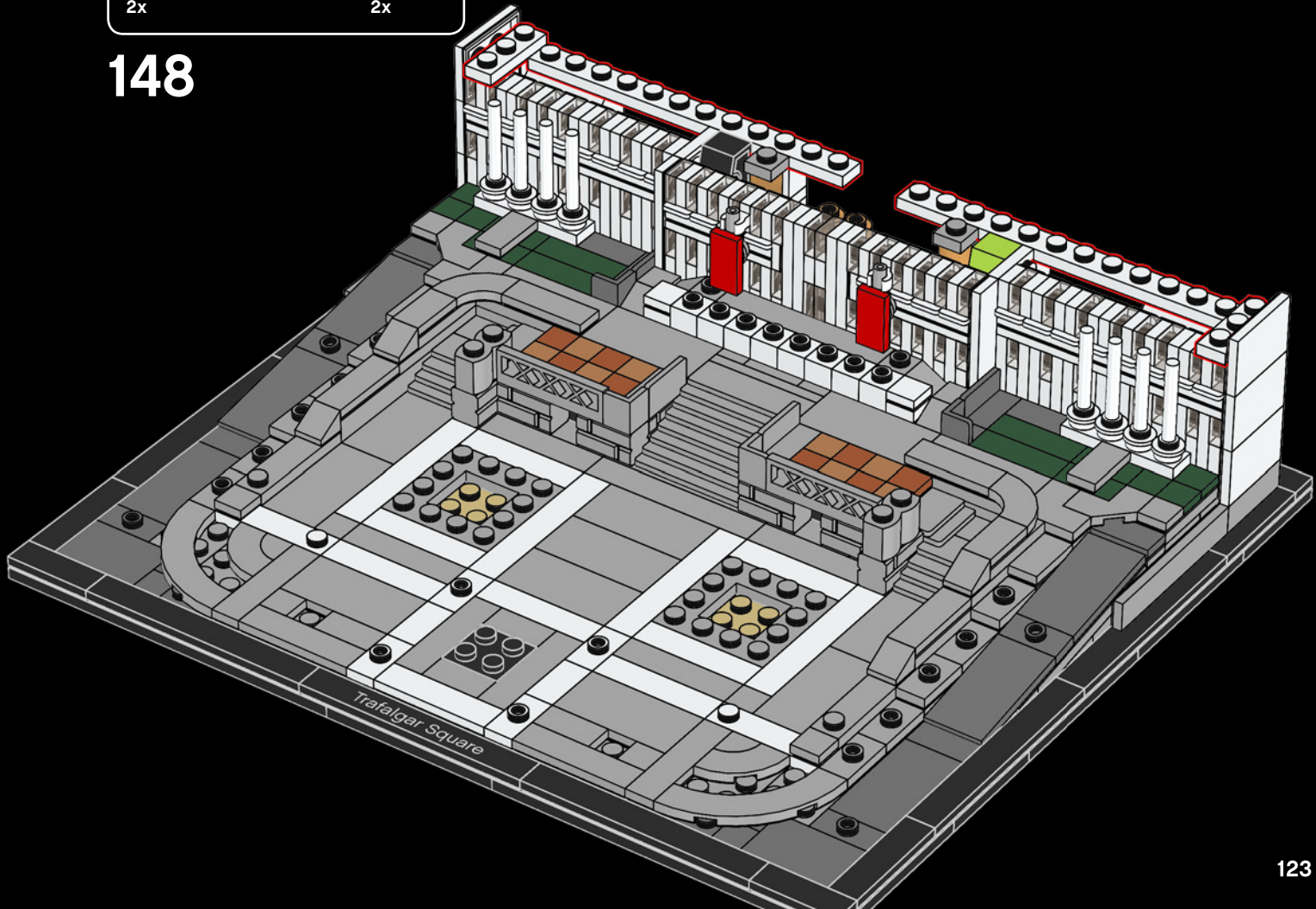



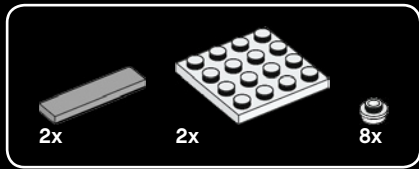

149

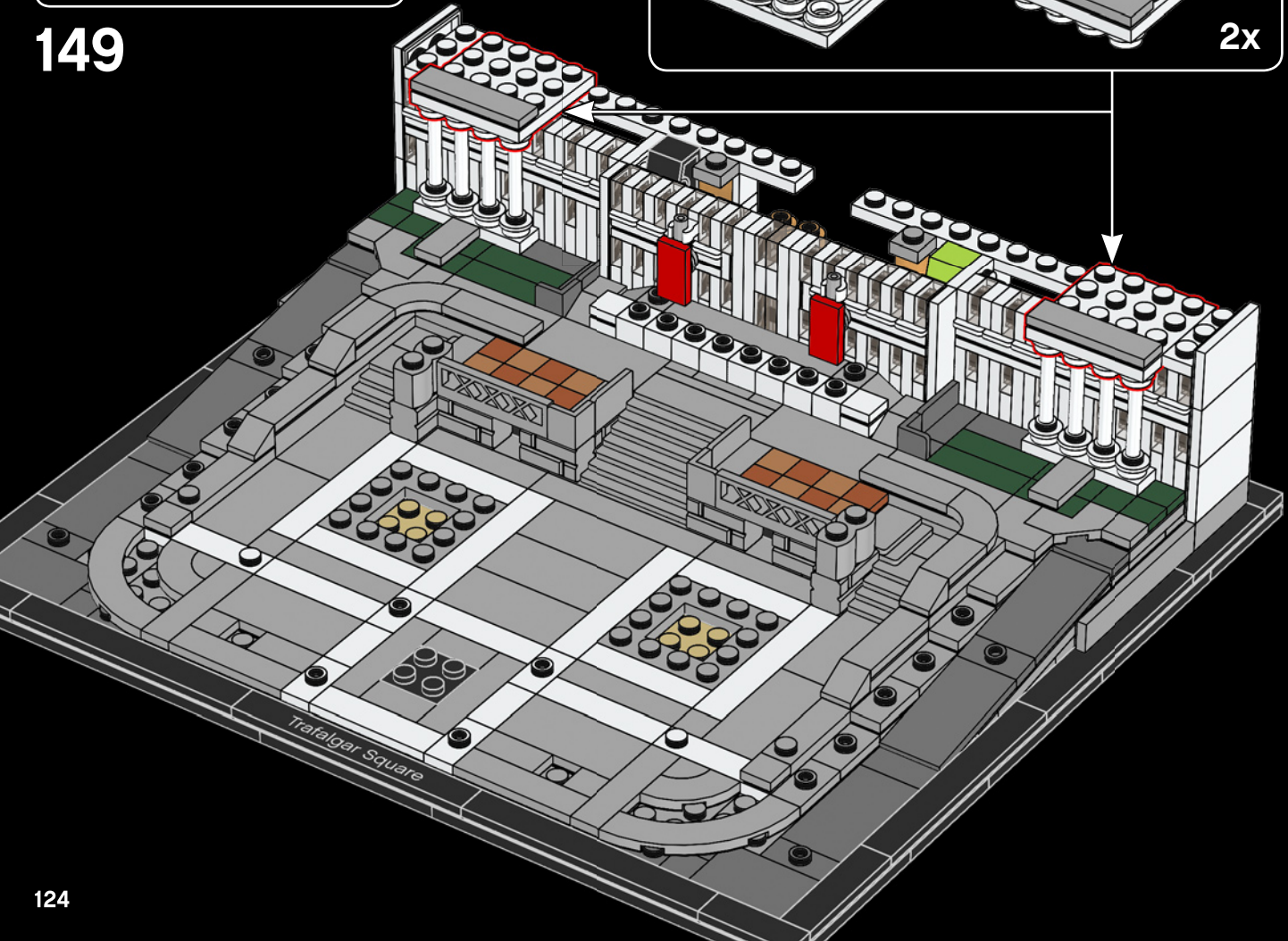
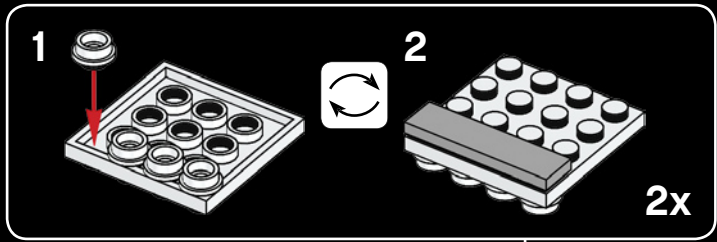



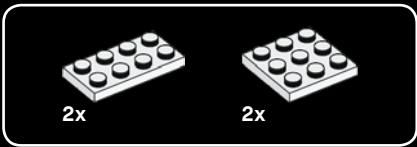

150

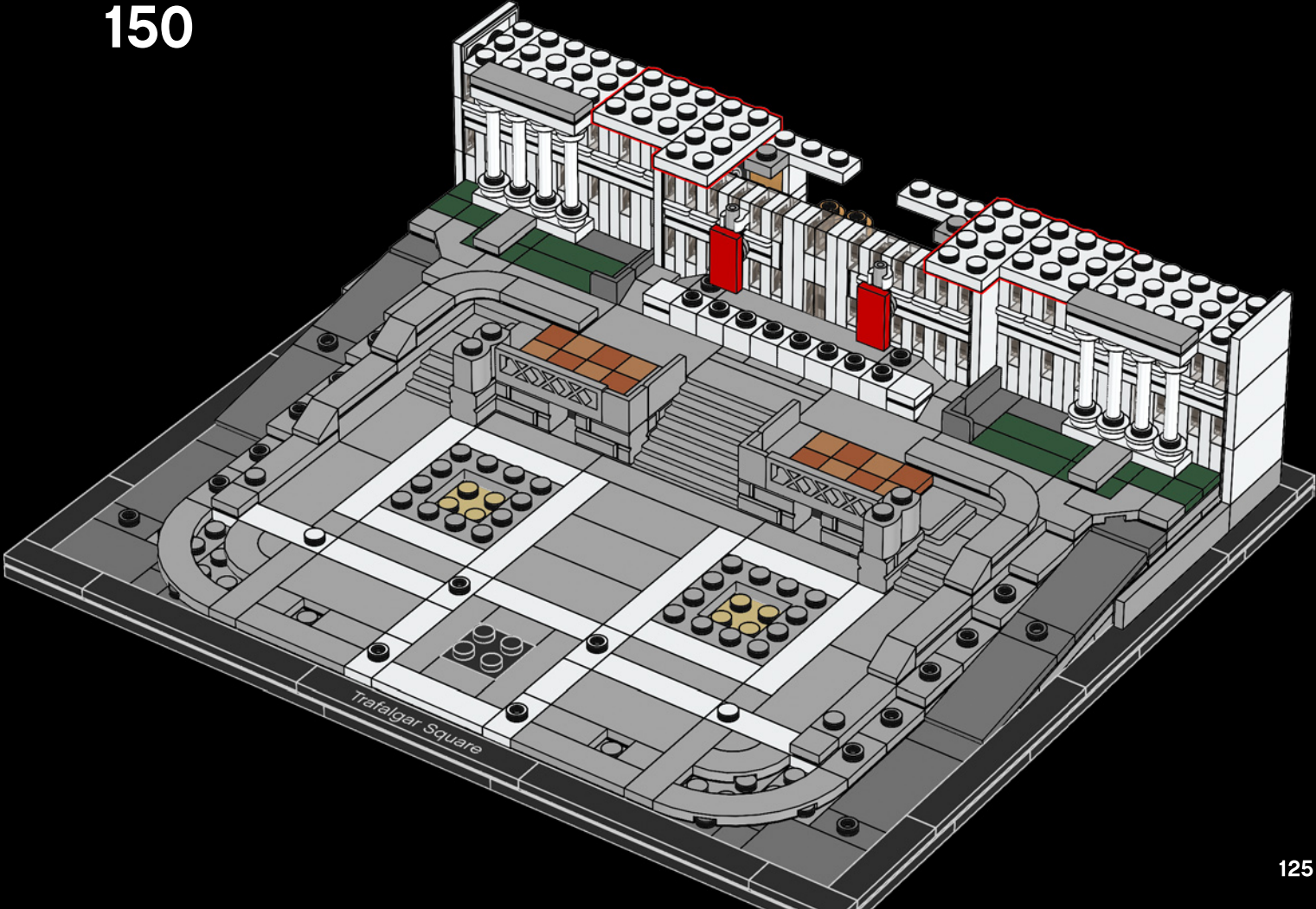



10x

151

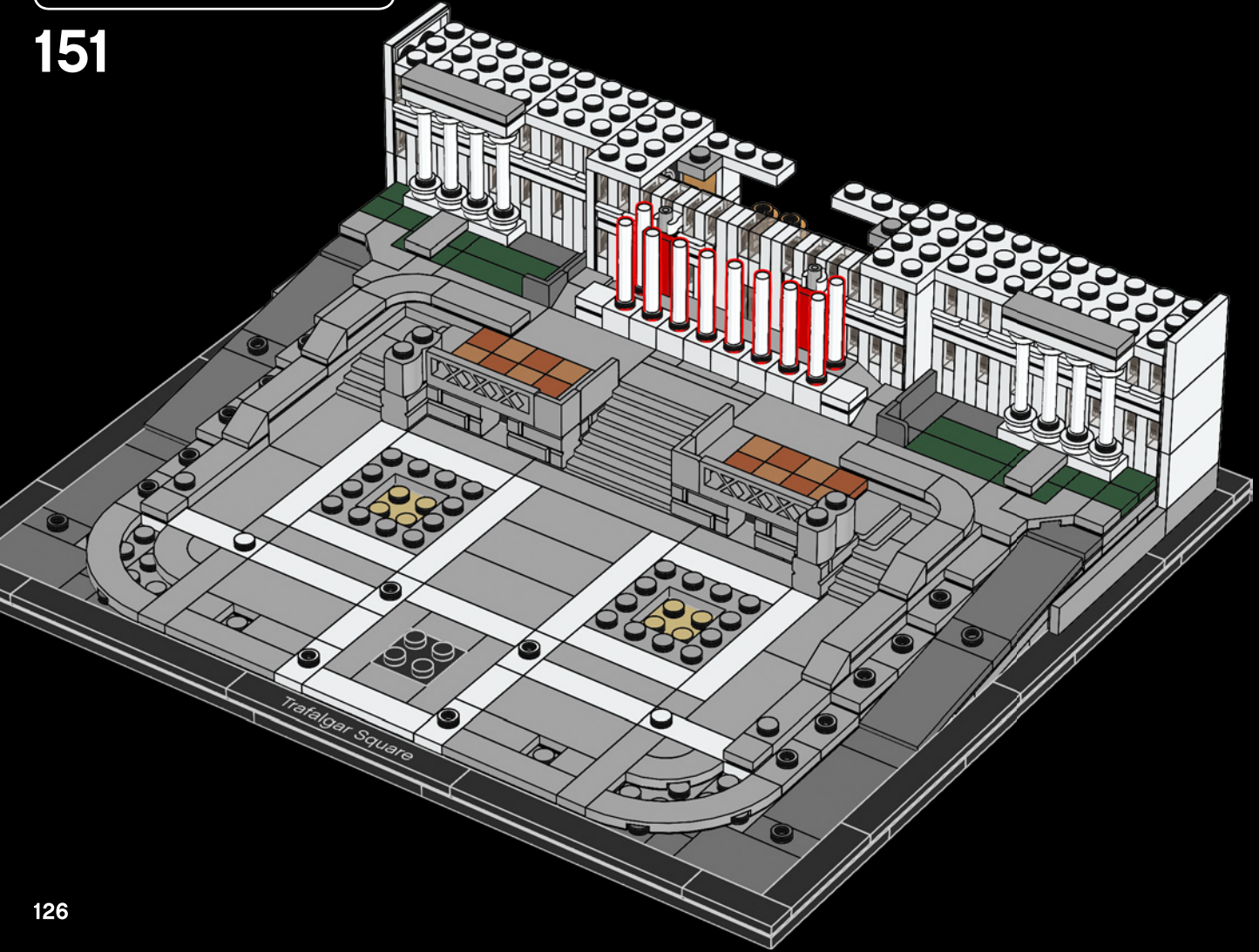

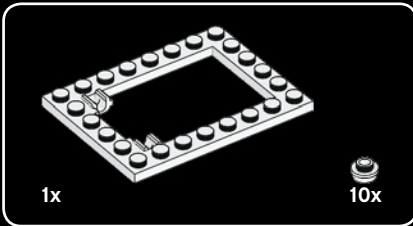
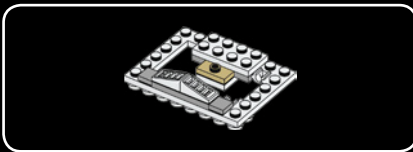

152

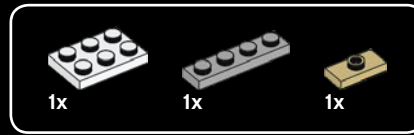
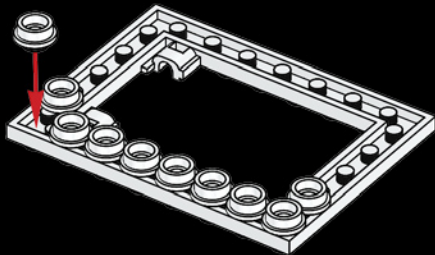

153

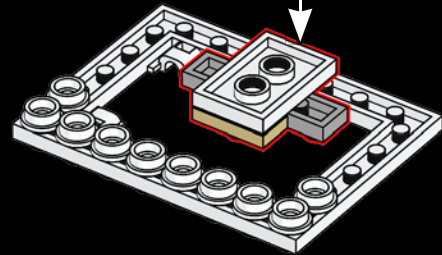
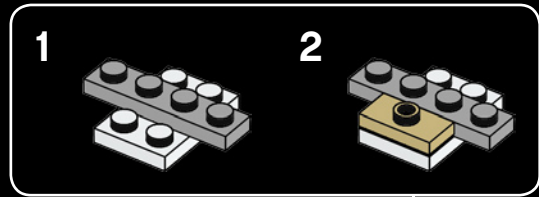

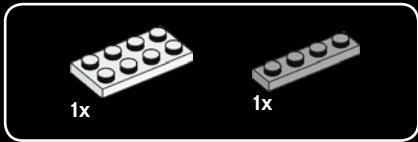

154

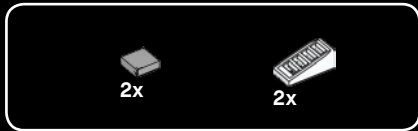
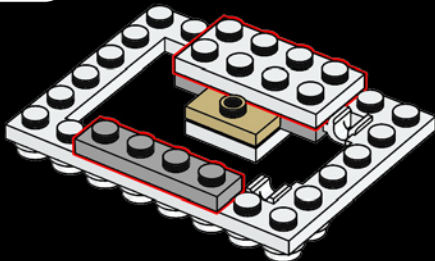

155

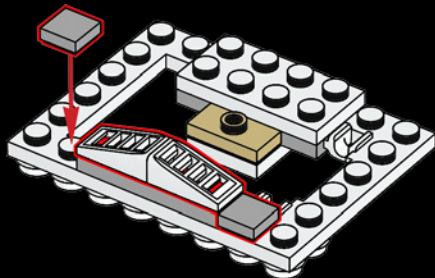



156

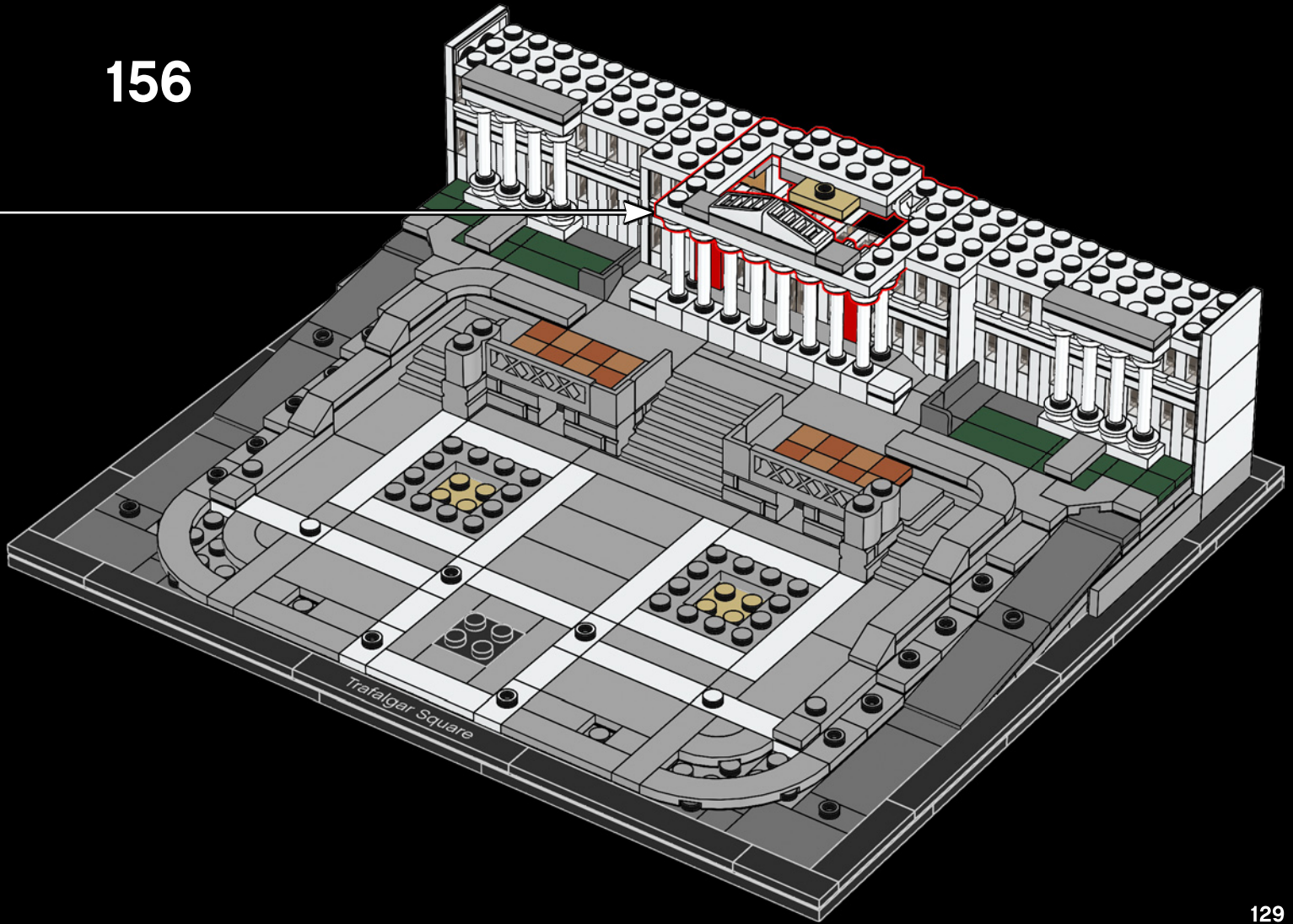

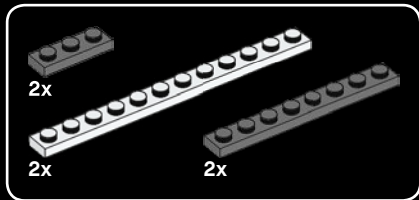

157

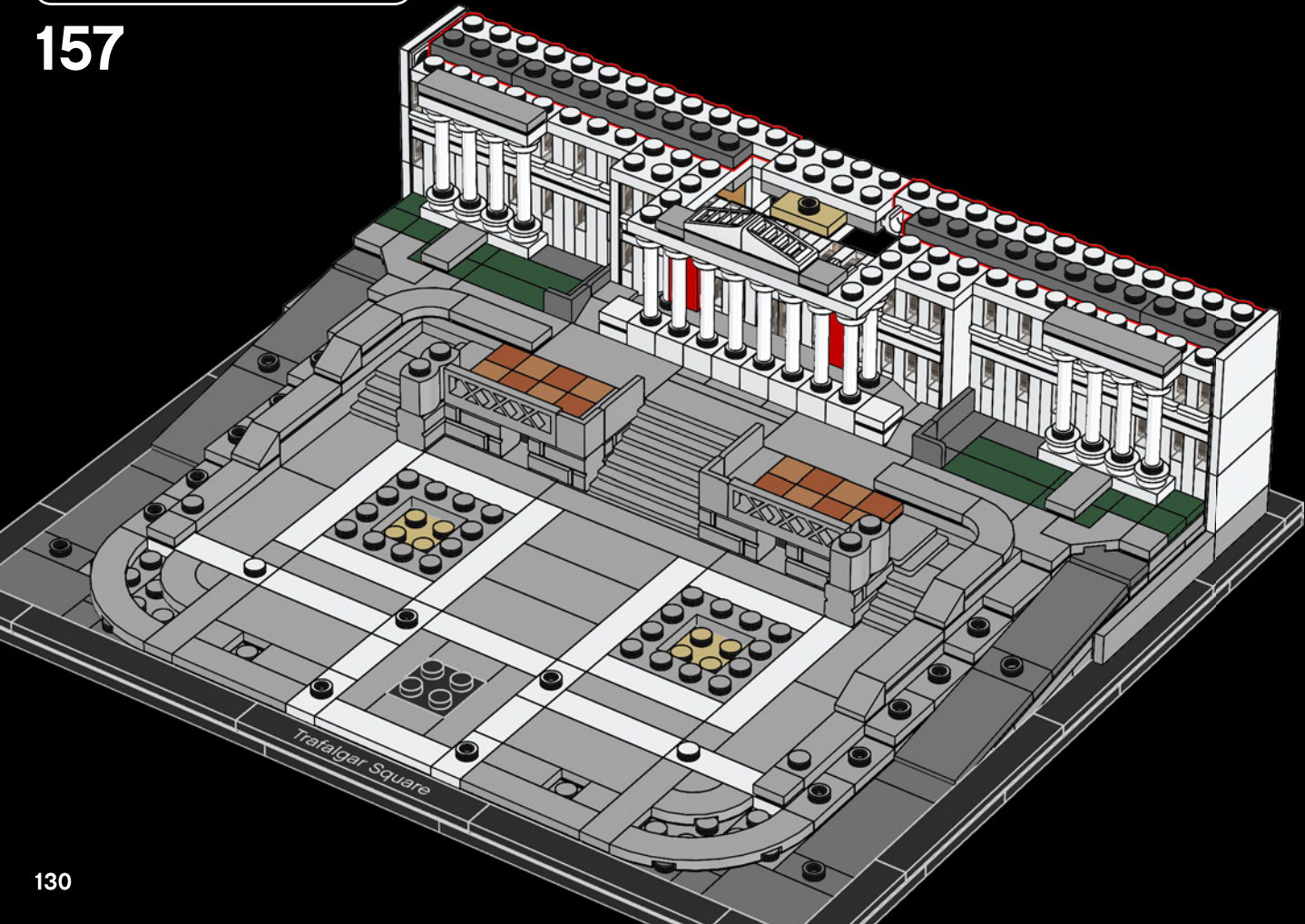

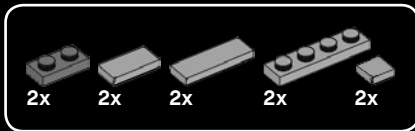

158

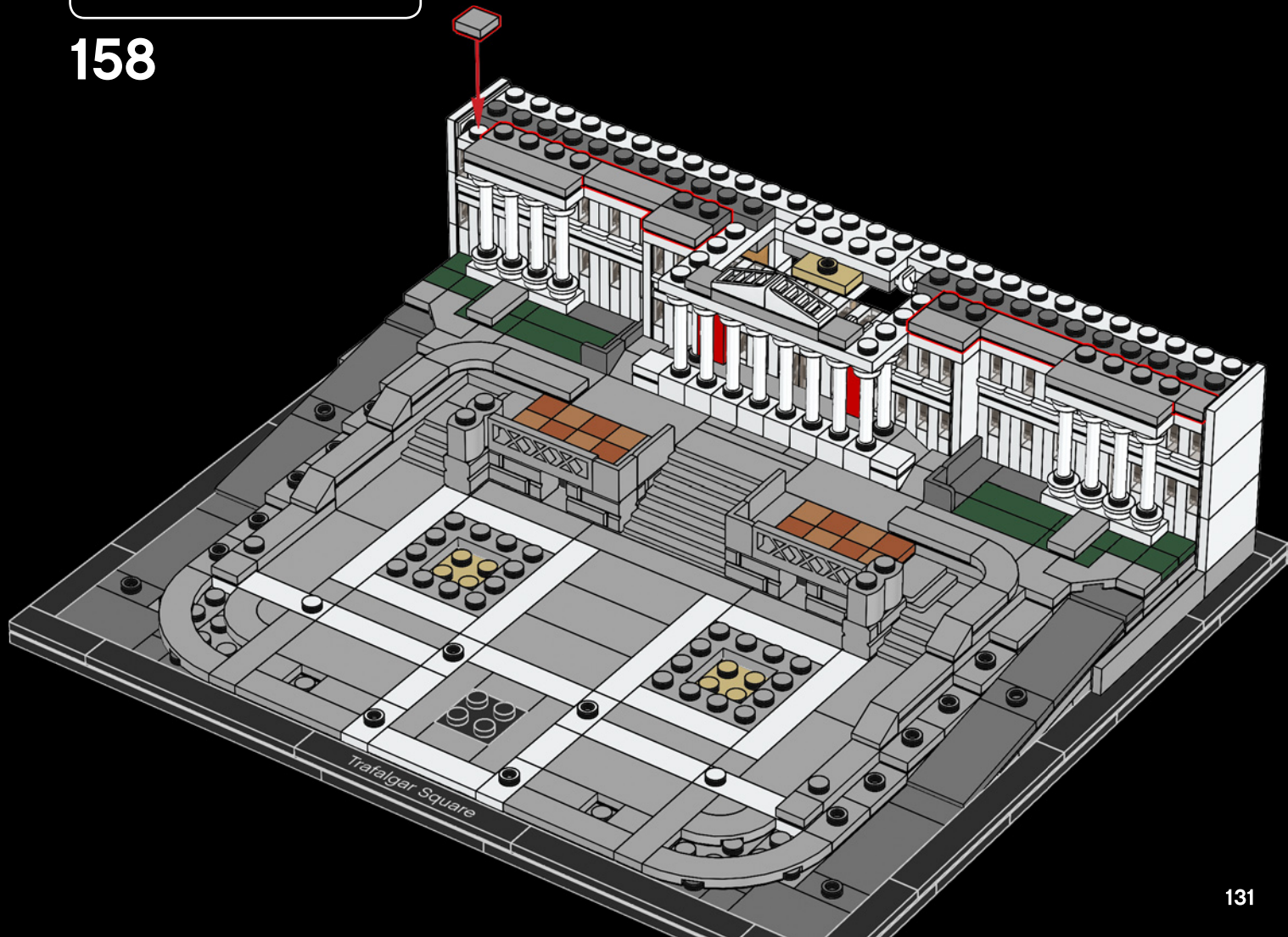





159

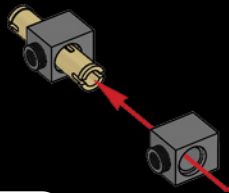

160

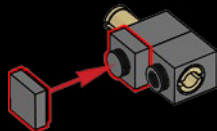

161

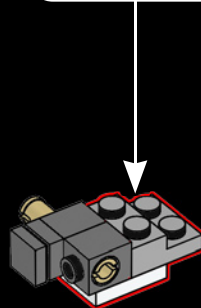
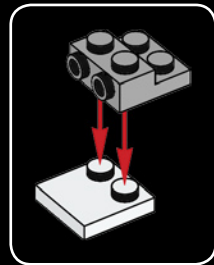





162

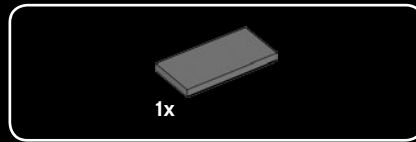
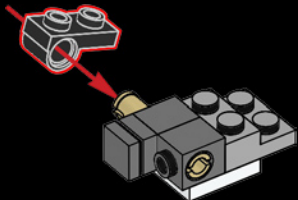

163

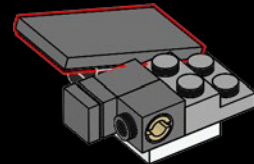

164

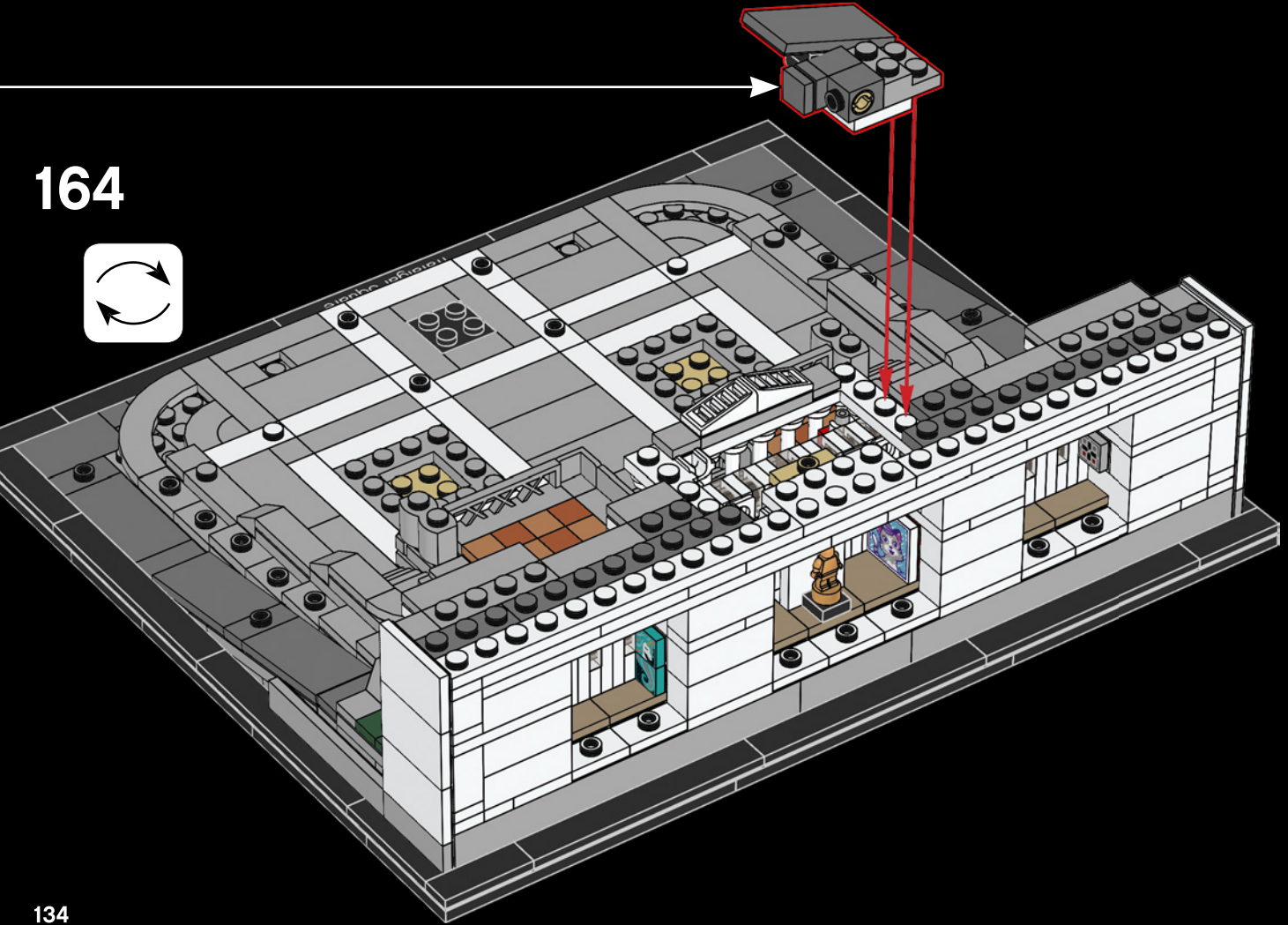



165

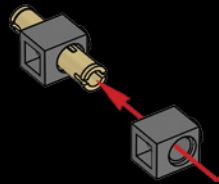

166

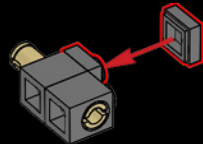

167

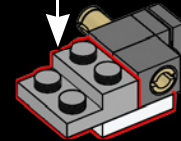
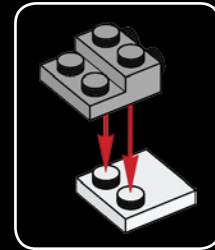



1x

168

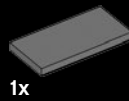
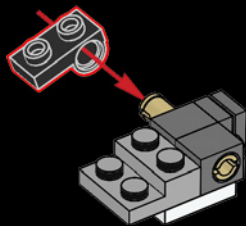

1x

169

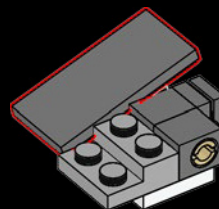



170

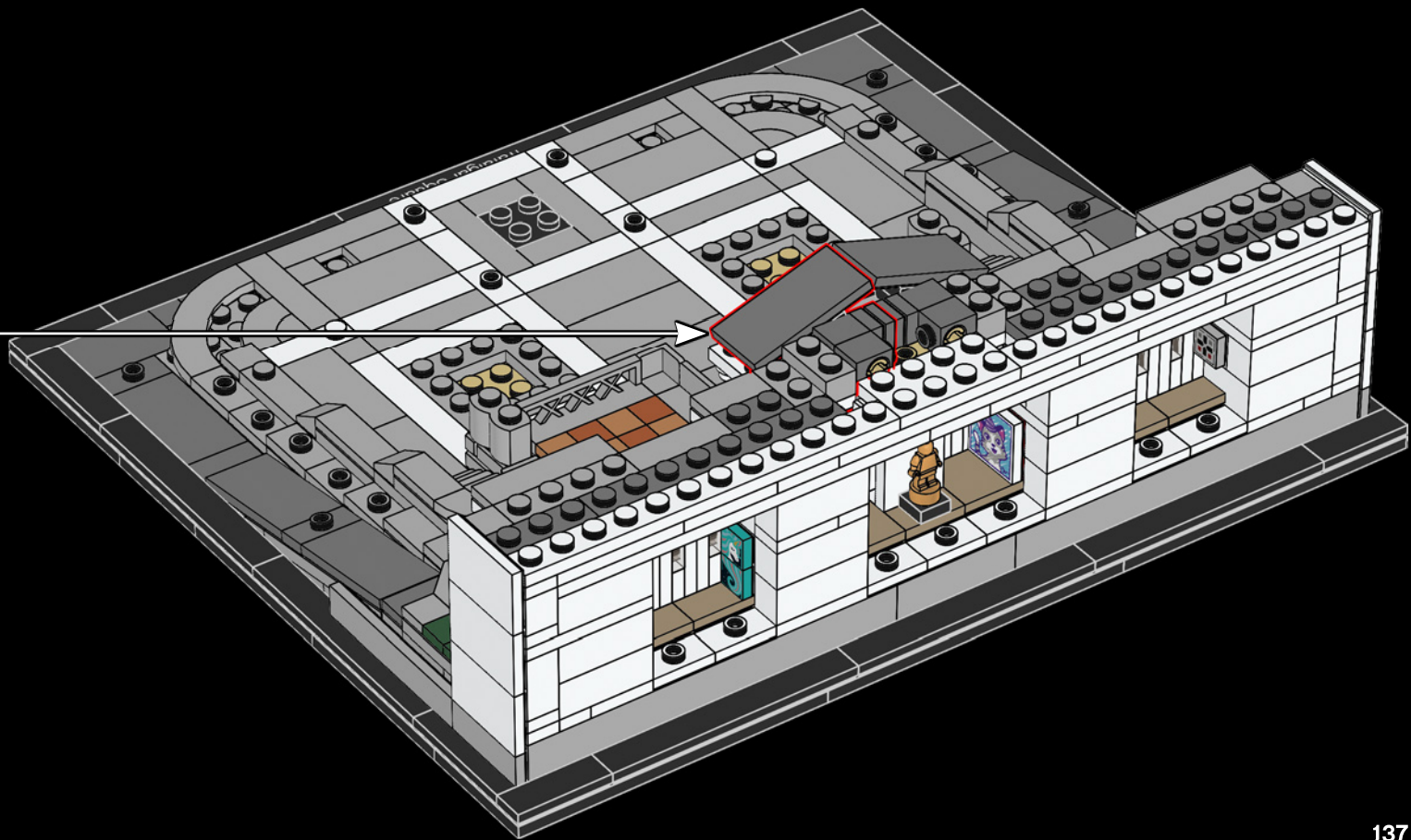



2x

171

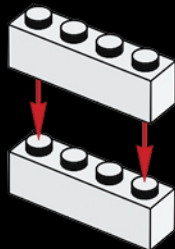

1x



1x

172

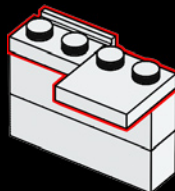

1x

173

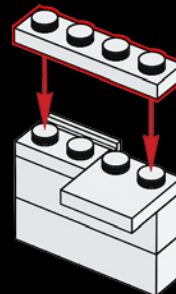

2x

174

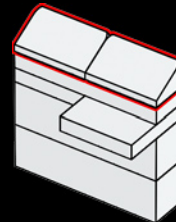

175

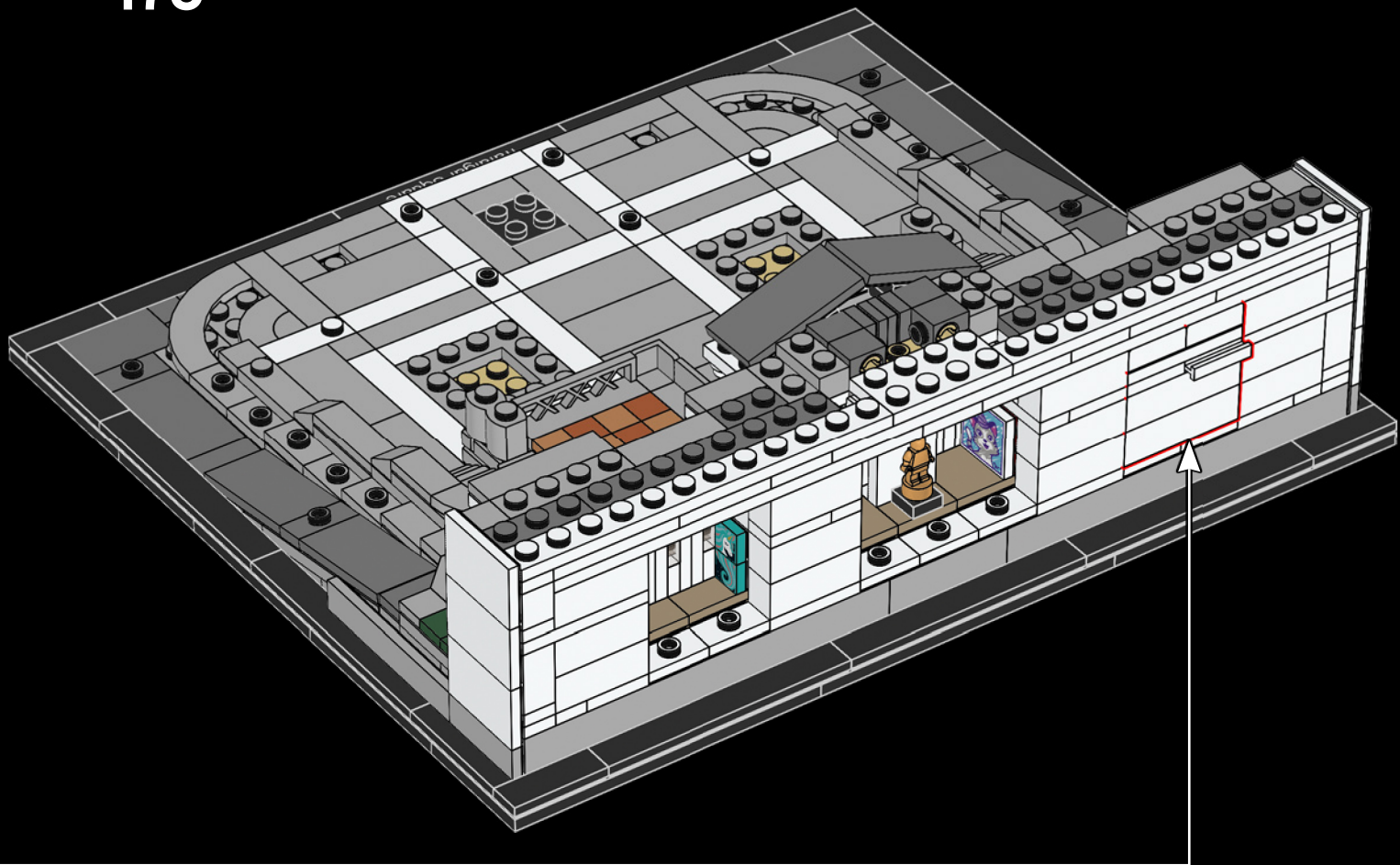

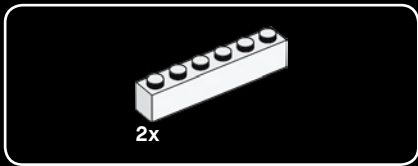

176

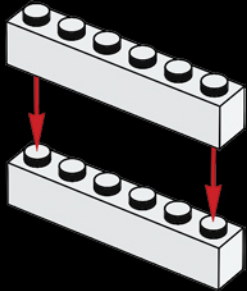

177

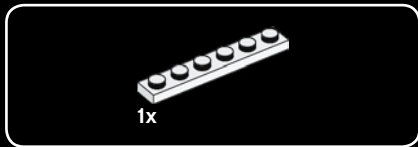
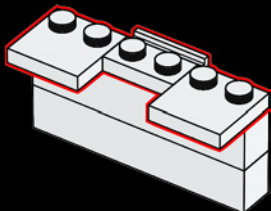

178

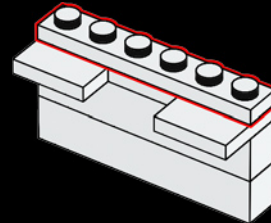

179

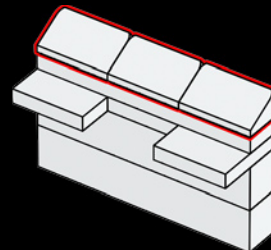



180

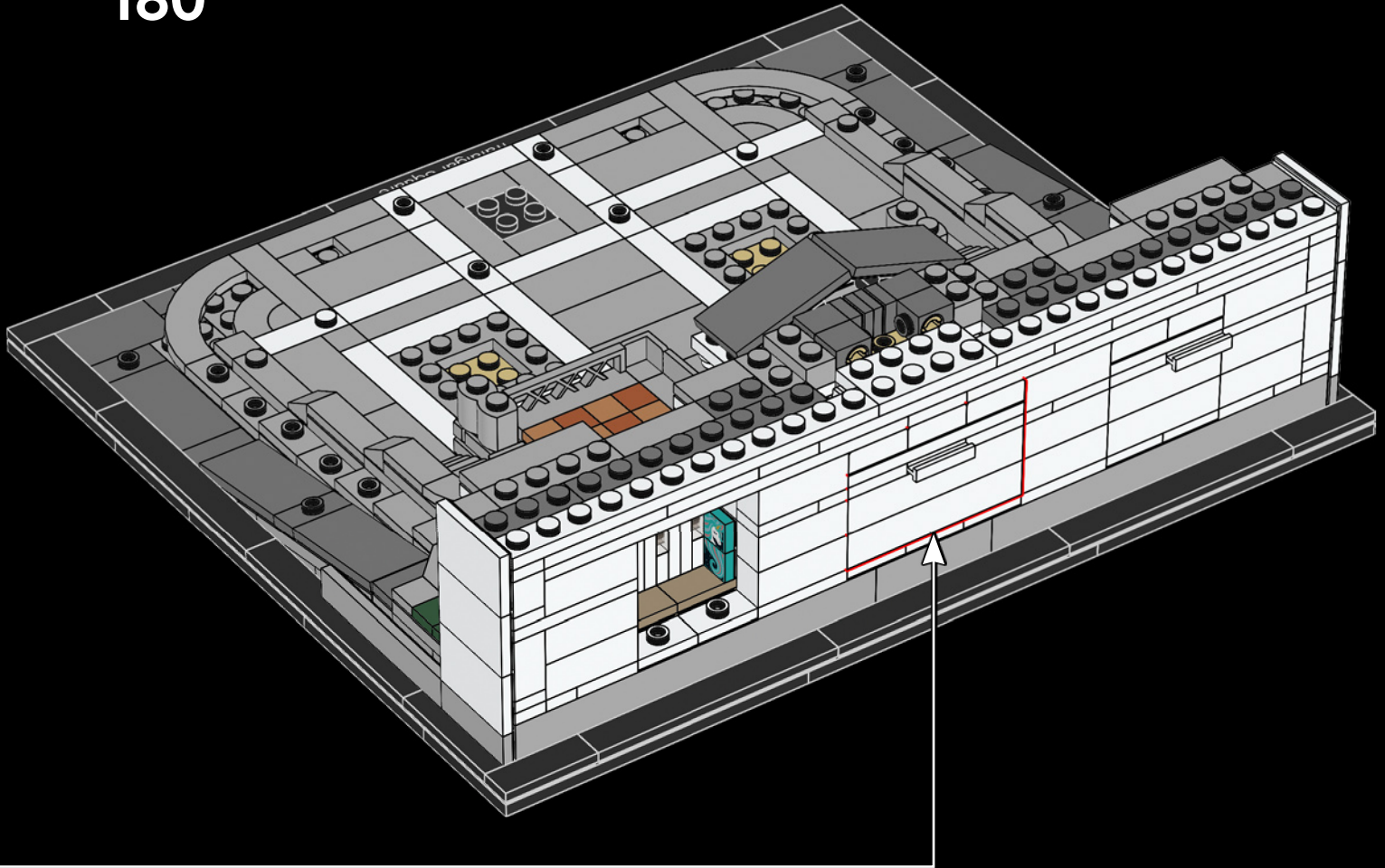

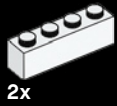

2x

# 181

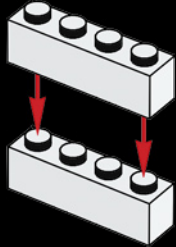

1x



1x

# 182

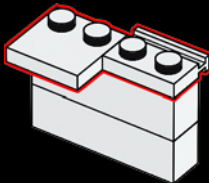

1x

# 183

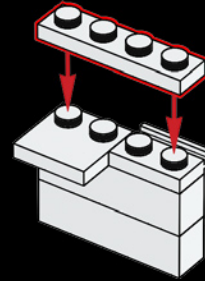

2x

# 184

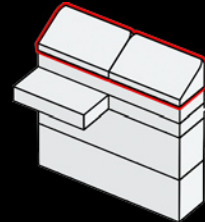

185

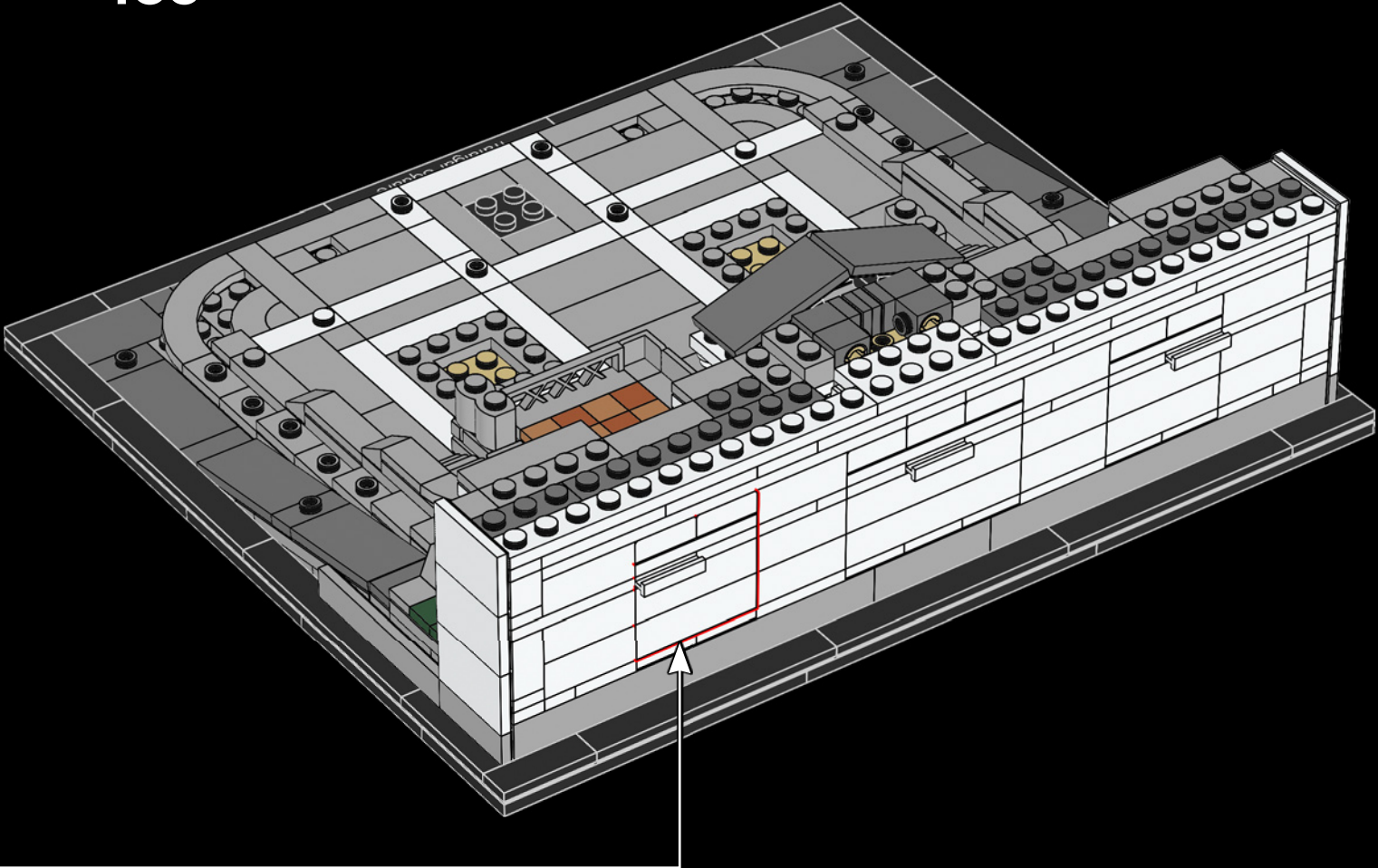

8x    2x    10x    6x

186



2x

6x

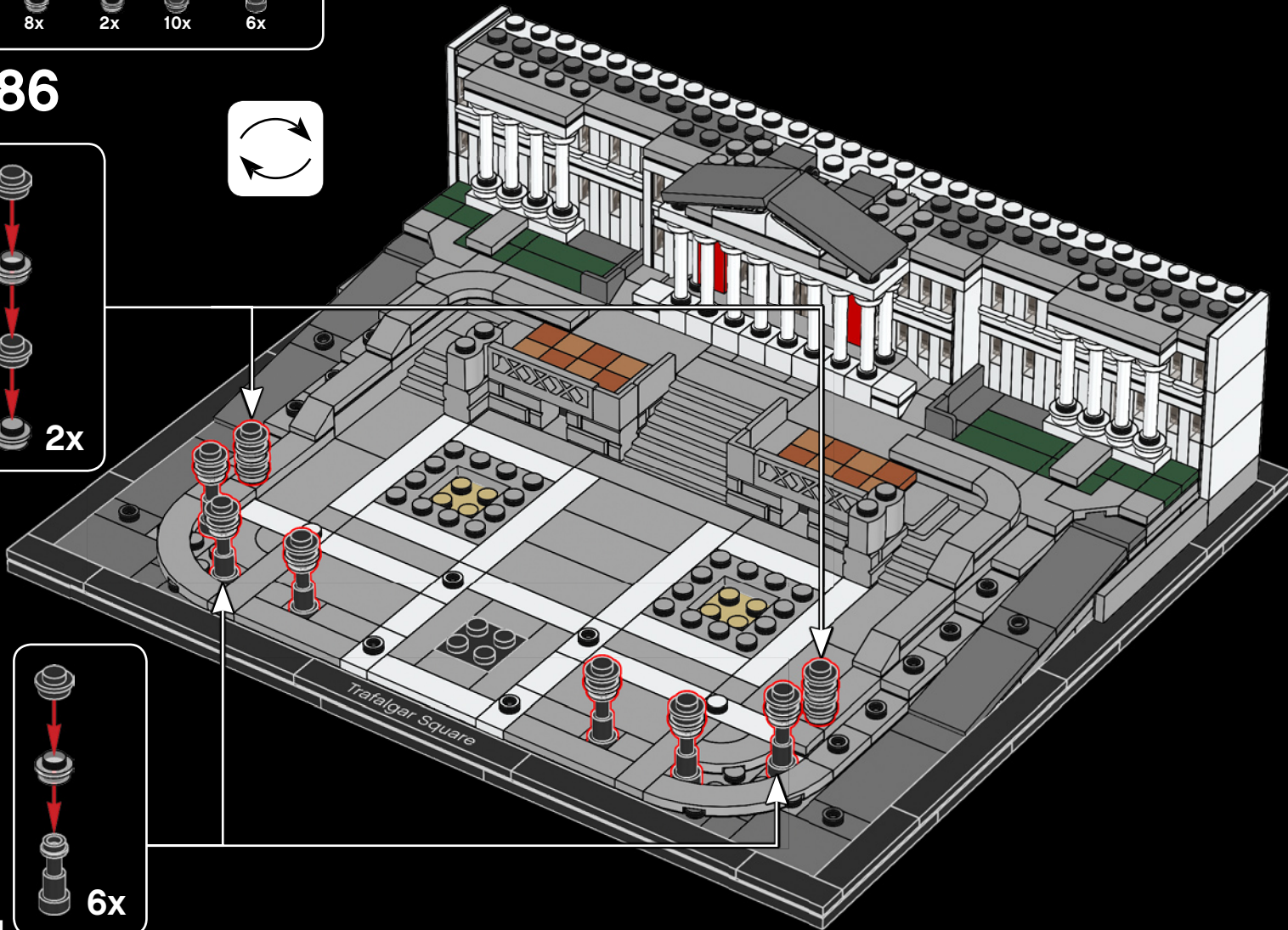







187

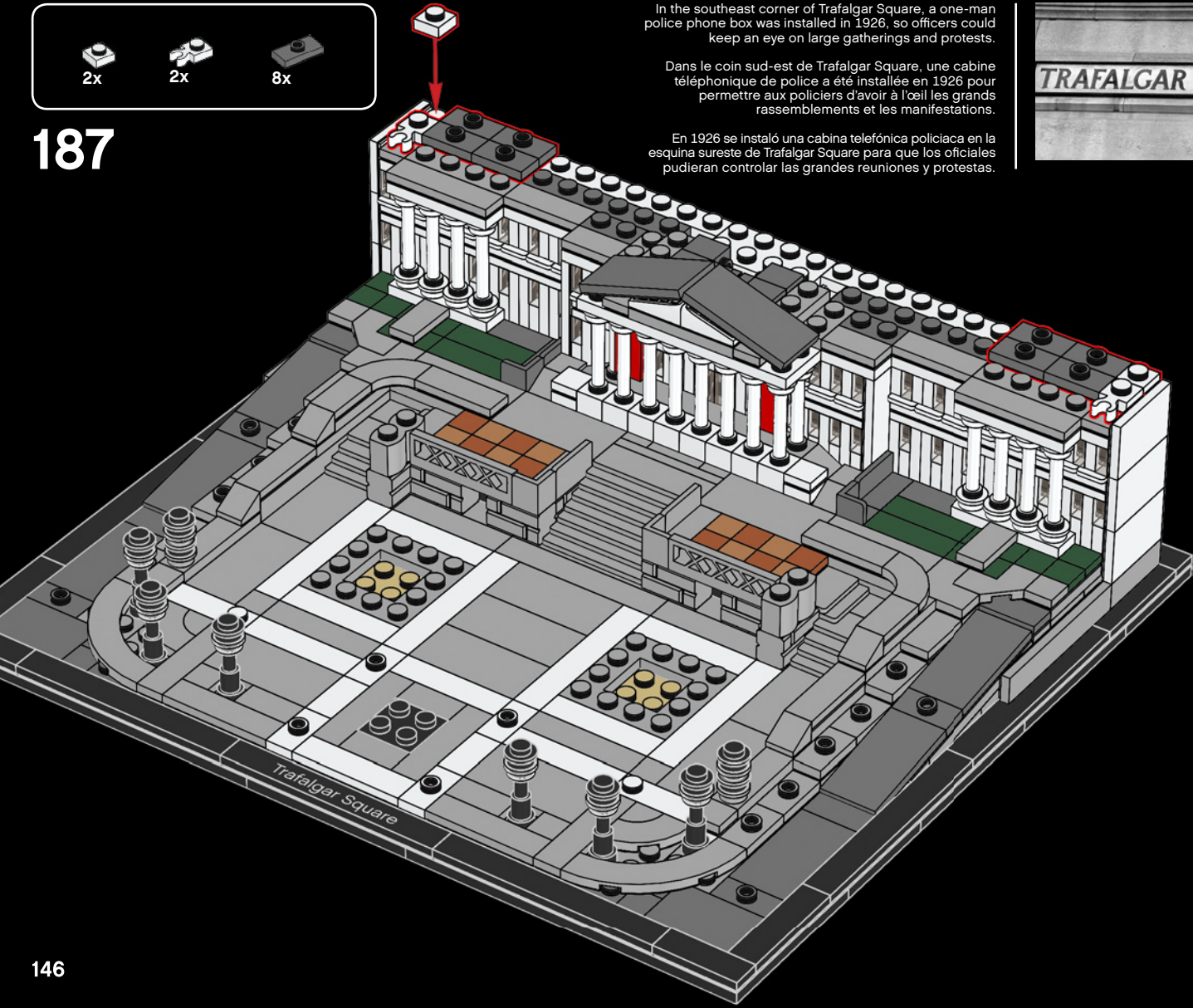

In the southeast corner of Trafalgar Square, a one-man police phone box was installed in 1926, so officers could keep an eye on large gatherings and protests.

Dans le coin sud-est de Trafalgar Square, une cabine téléphonique de police a été installée en 1926 pour permettre aux policiers d'avoir à l'œil les grands rassemblements et les manifestations.

En 1926 se instaló una cabina telefónica policiaca en la esquina sureste de Trafalgar Square para que los oficiales pudieran controlar las grandes reuniones y protestas.



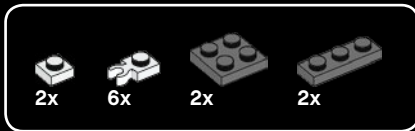

188

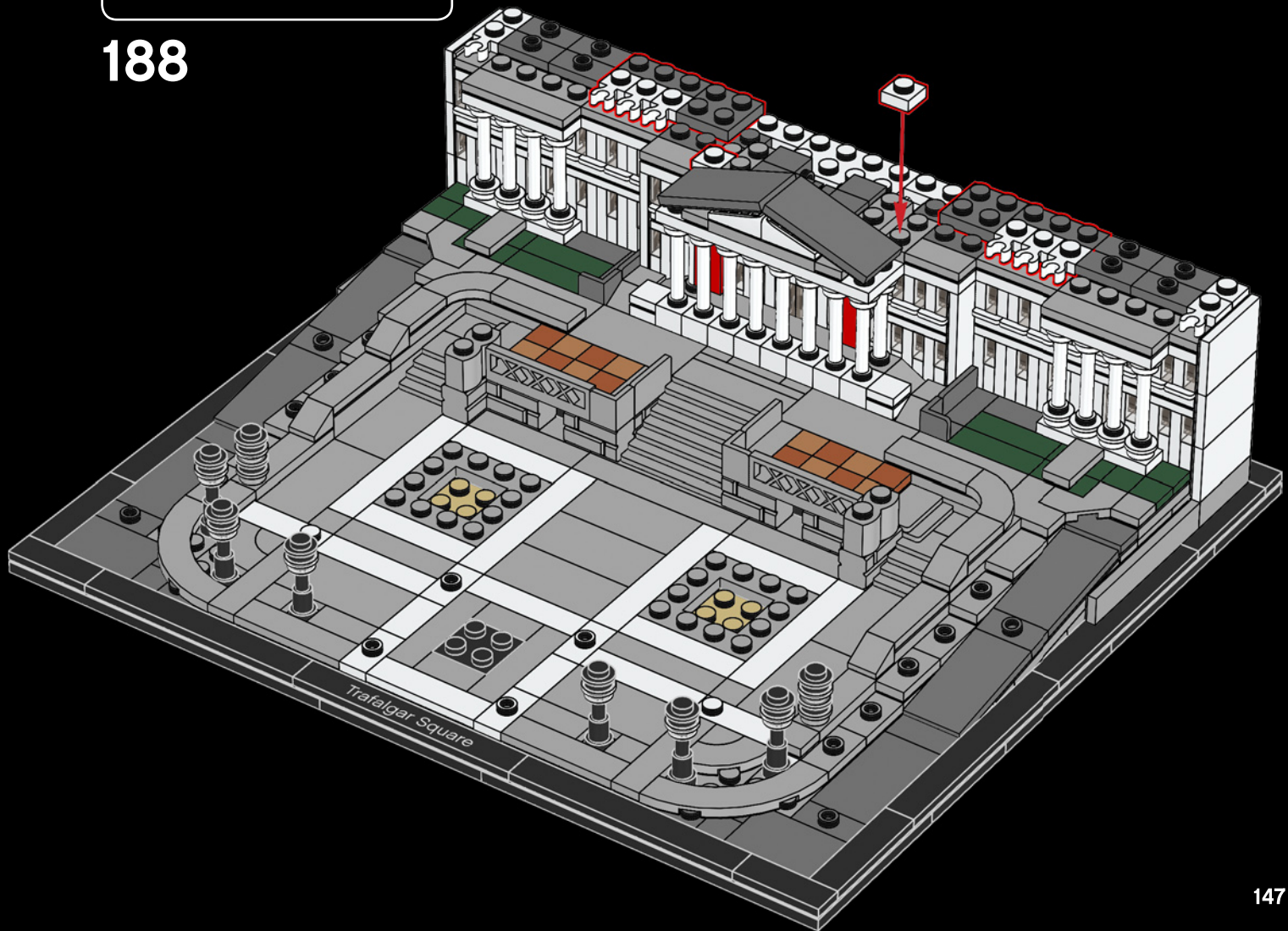



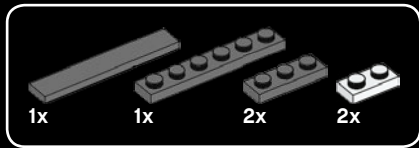

189

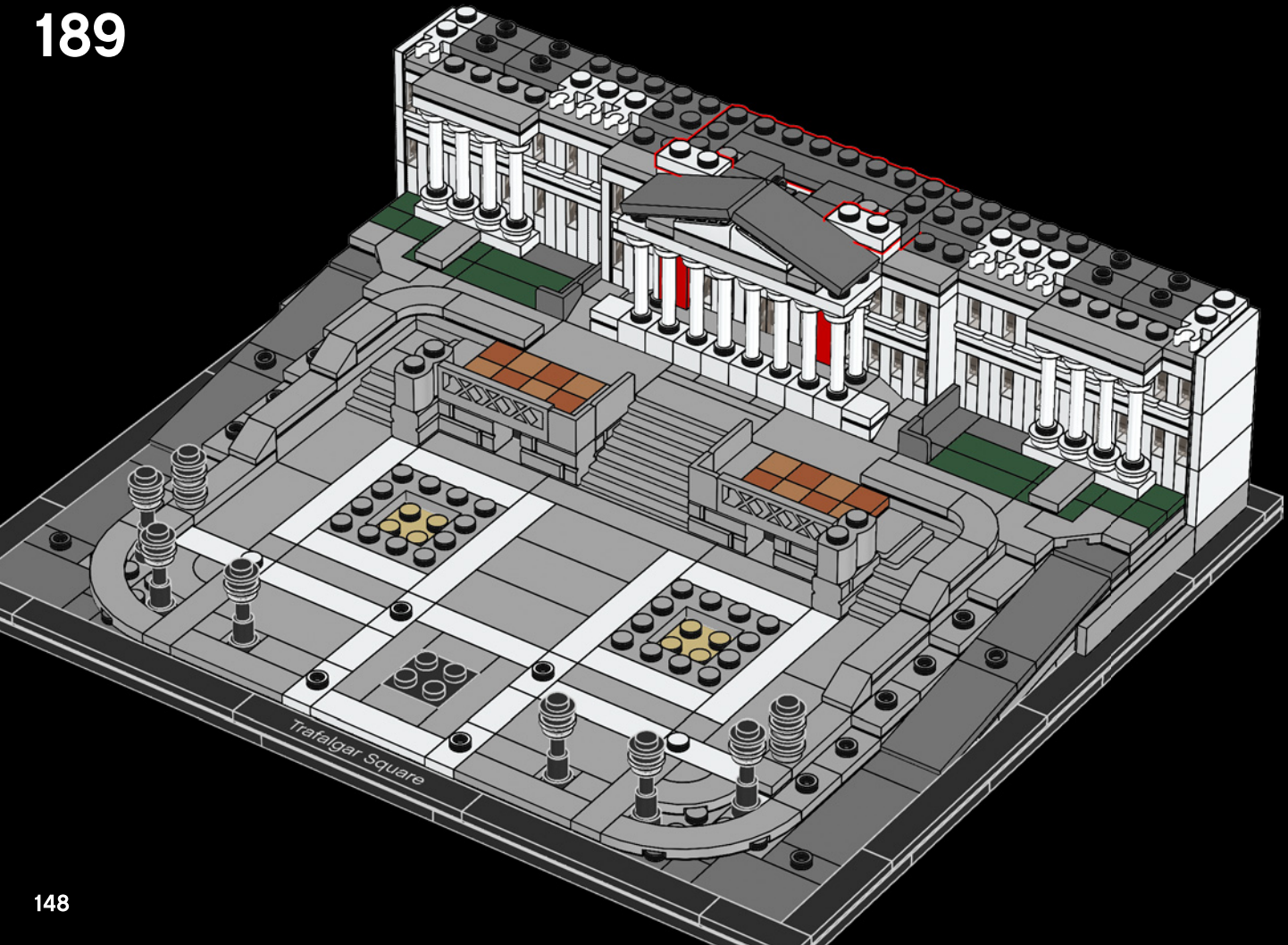





190

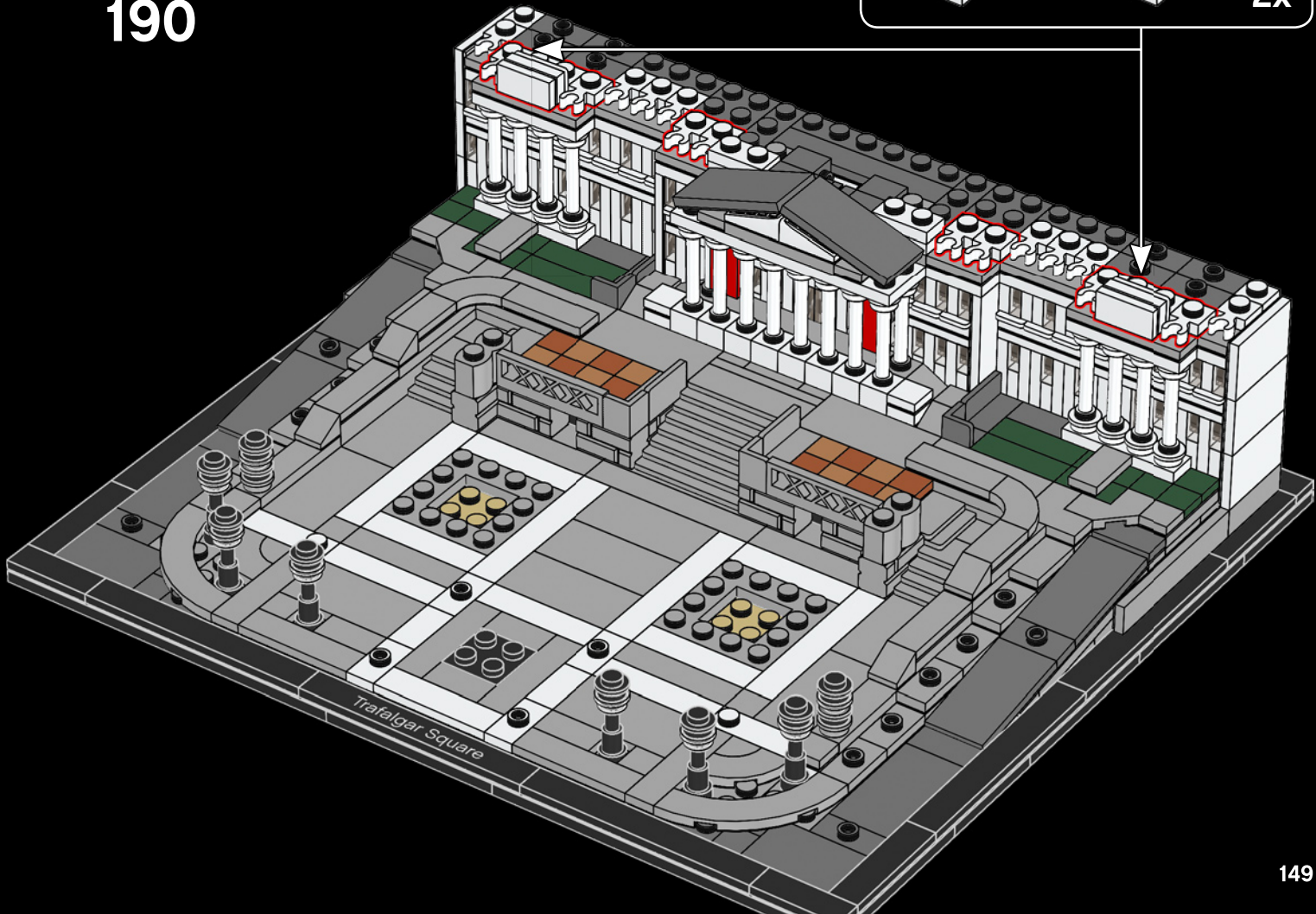
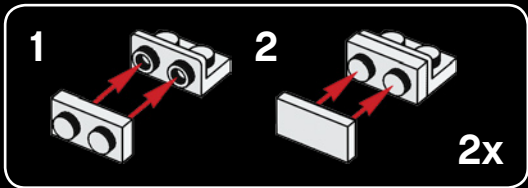

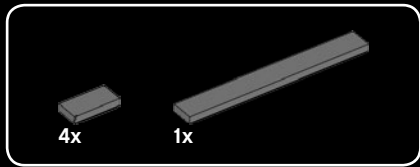

191

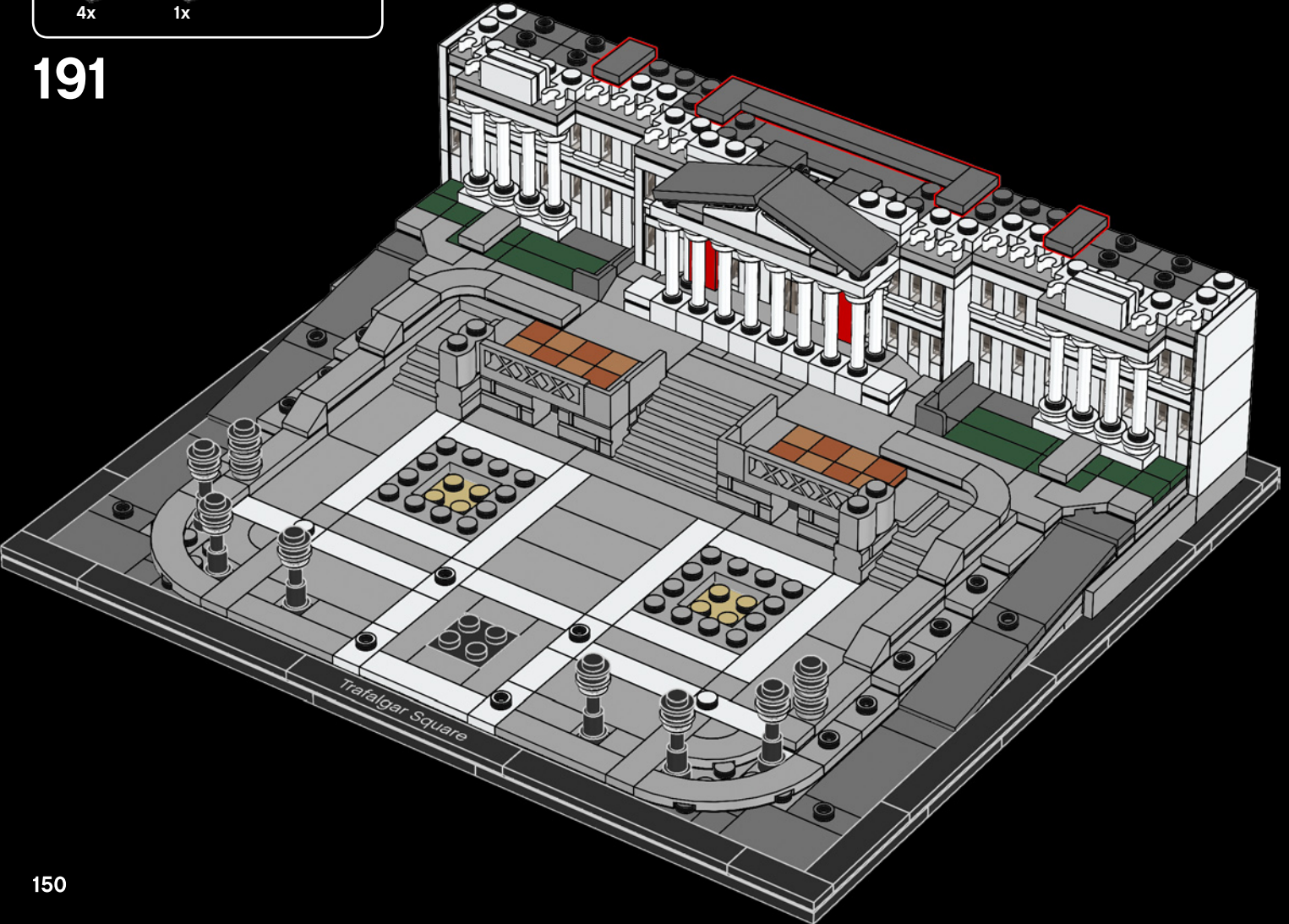



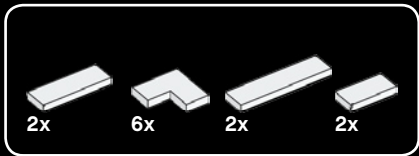

192





193

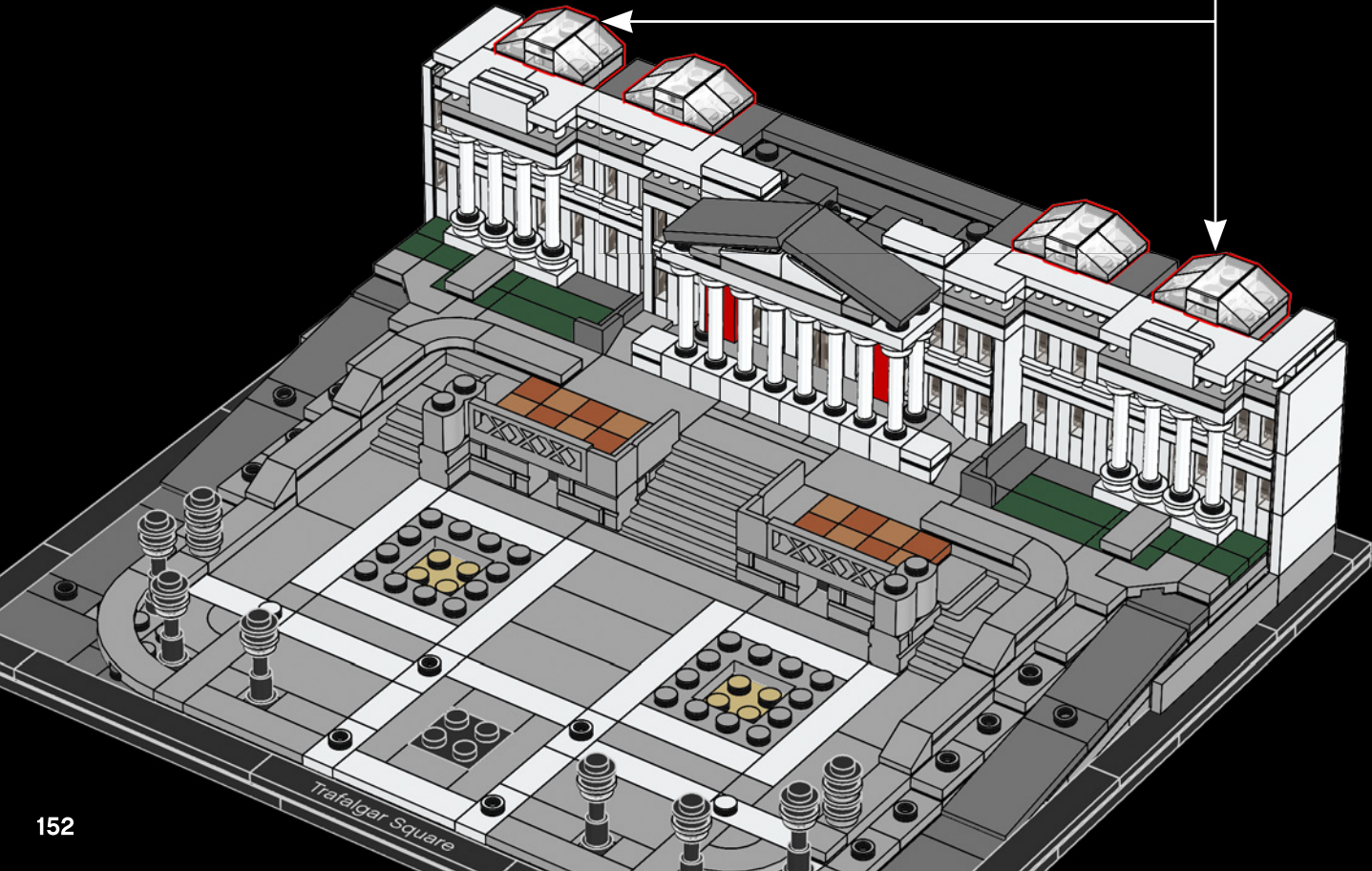
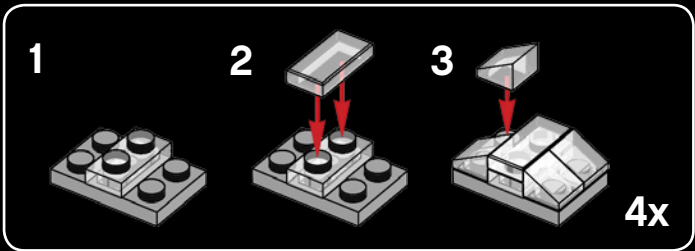



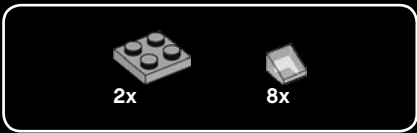

194

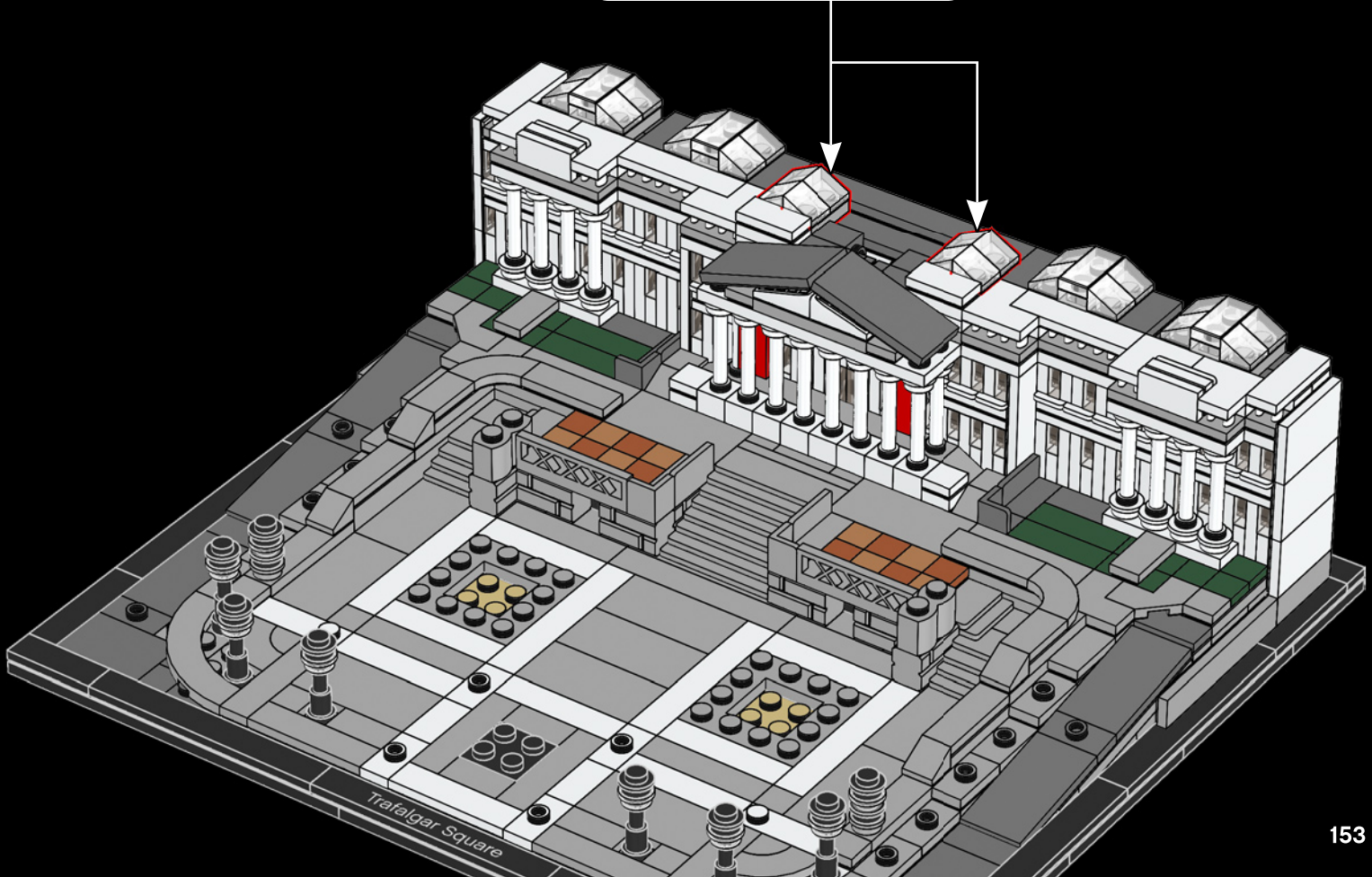
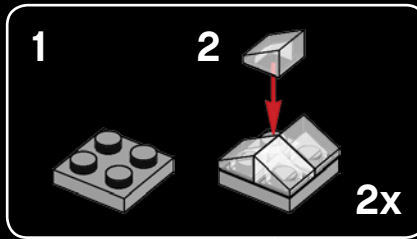

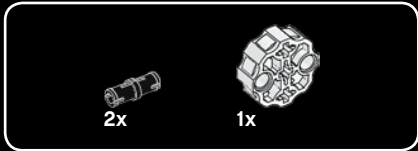

195

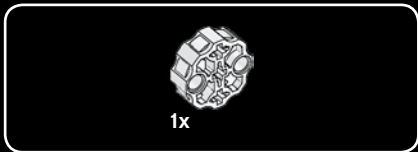
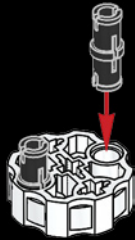

196



197

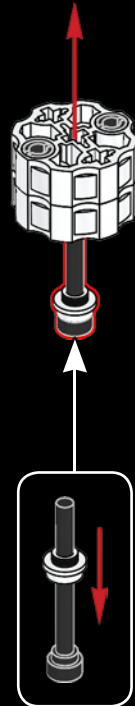



198

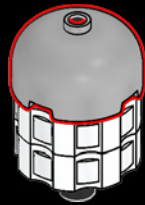



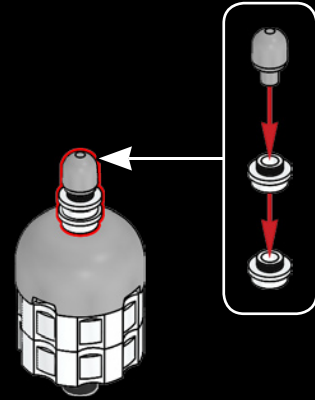

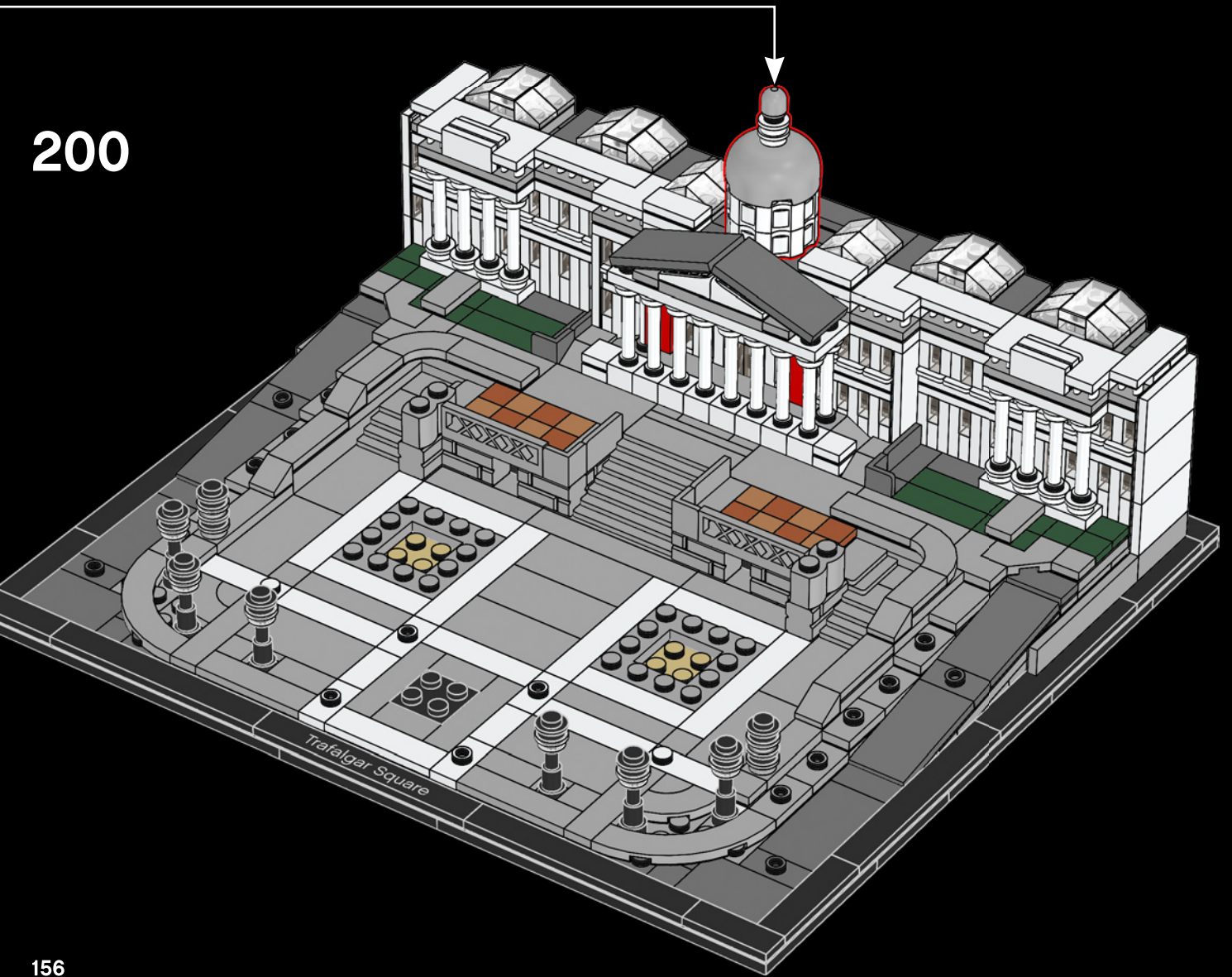

199



200





-  3x
-  1x
-  1x
-  1x
-  1x
-  1x

# 201

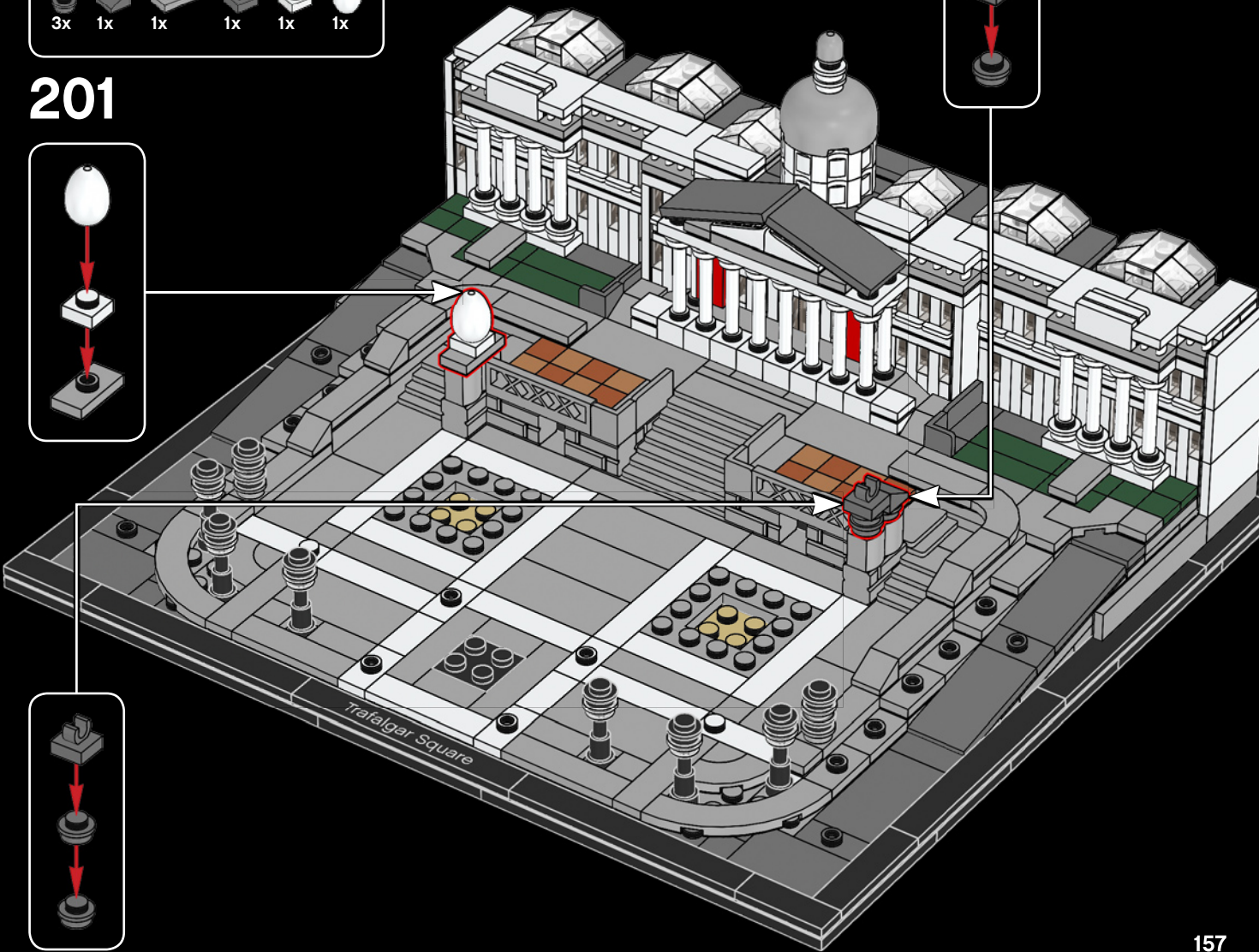
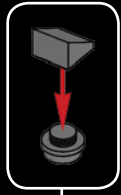
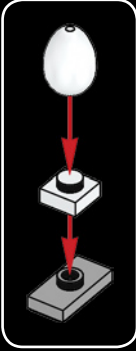



4x

202

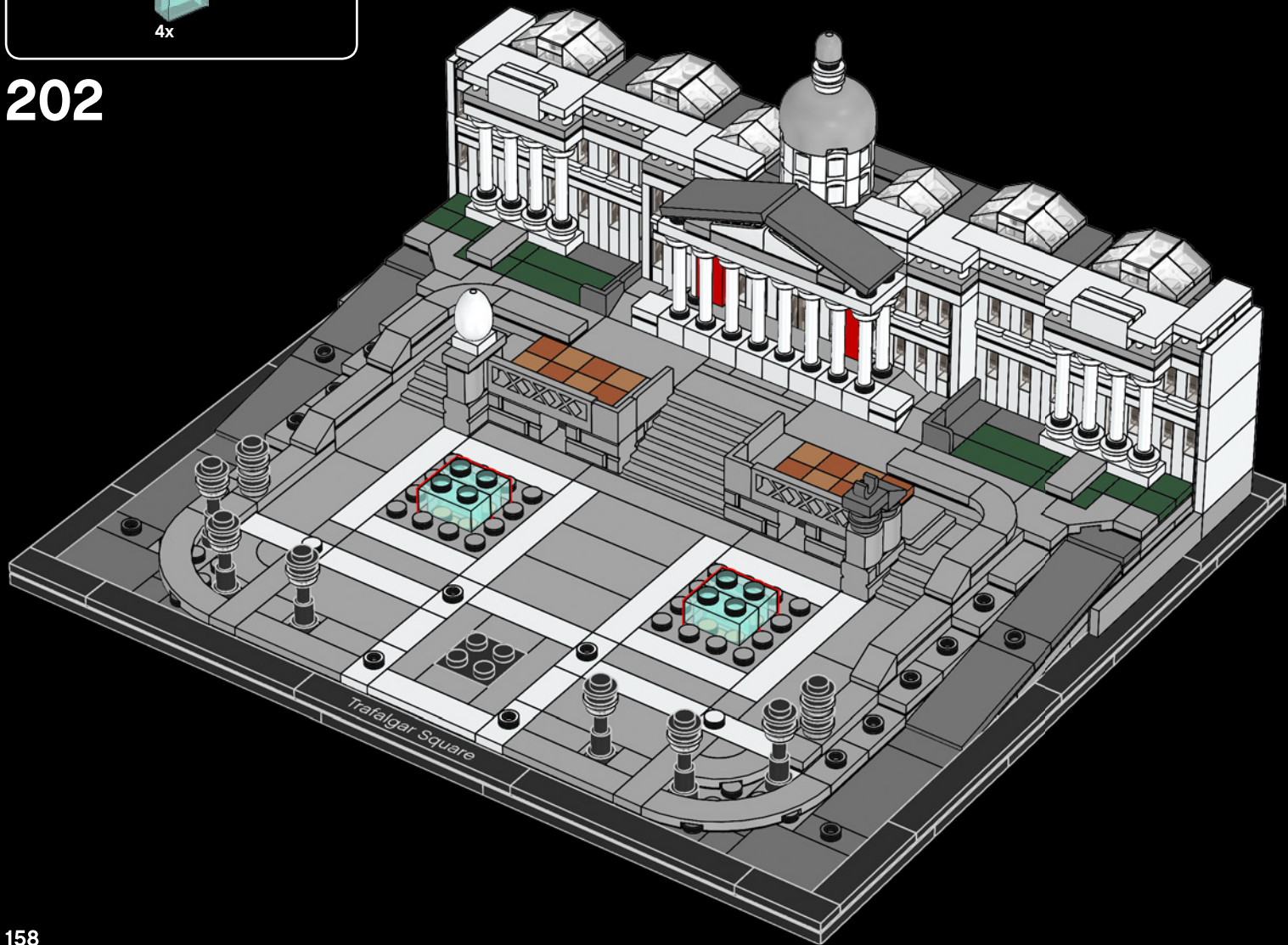





4x



4x



4x

# 203

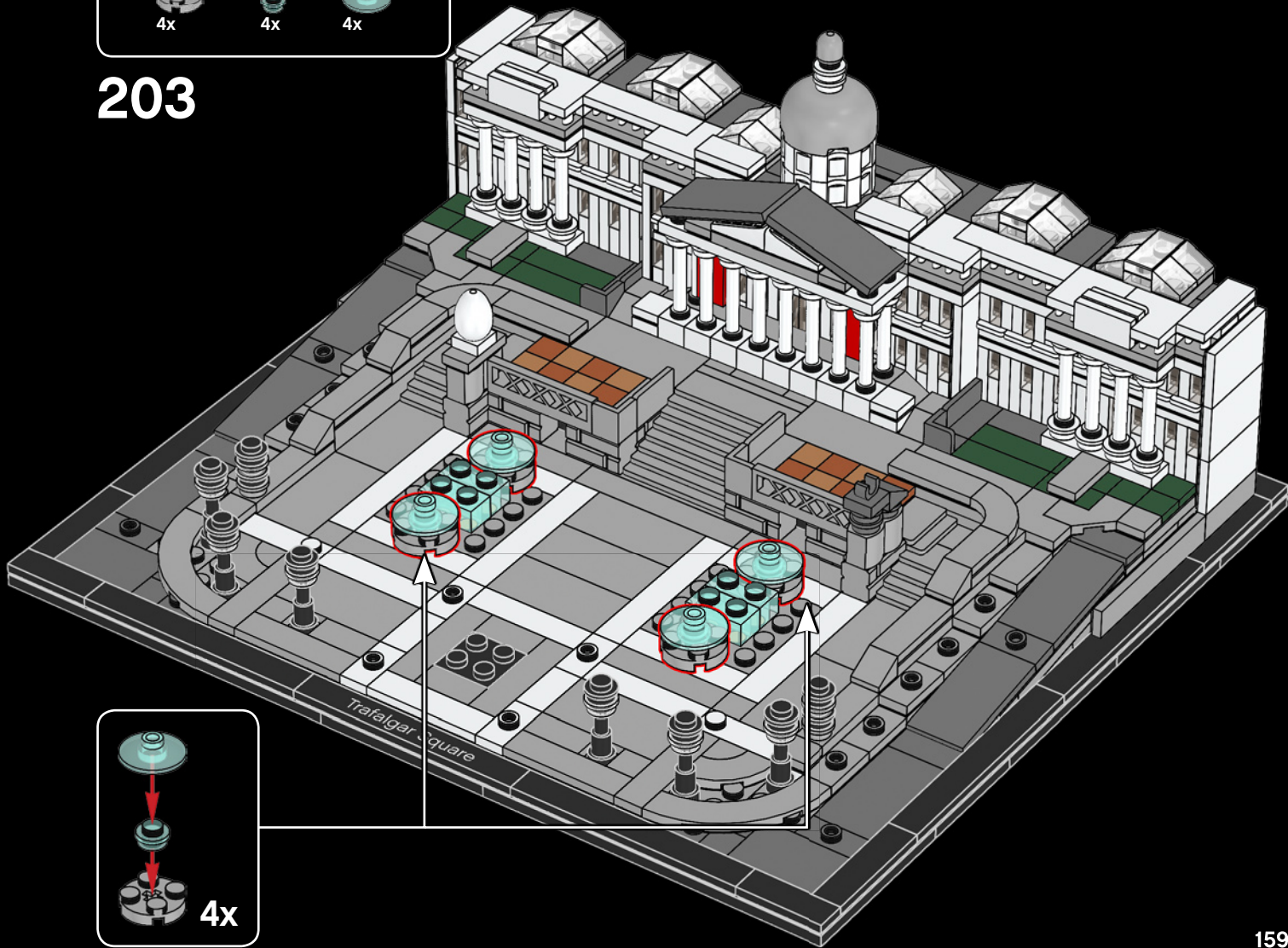

4x



8x



8x

# 204

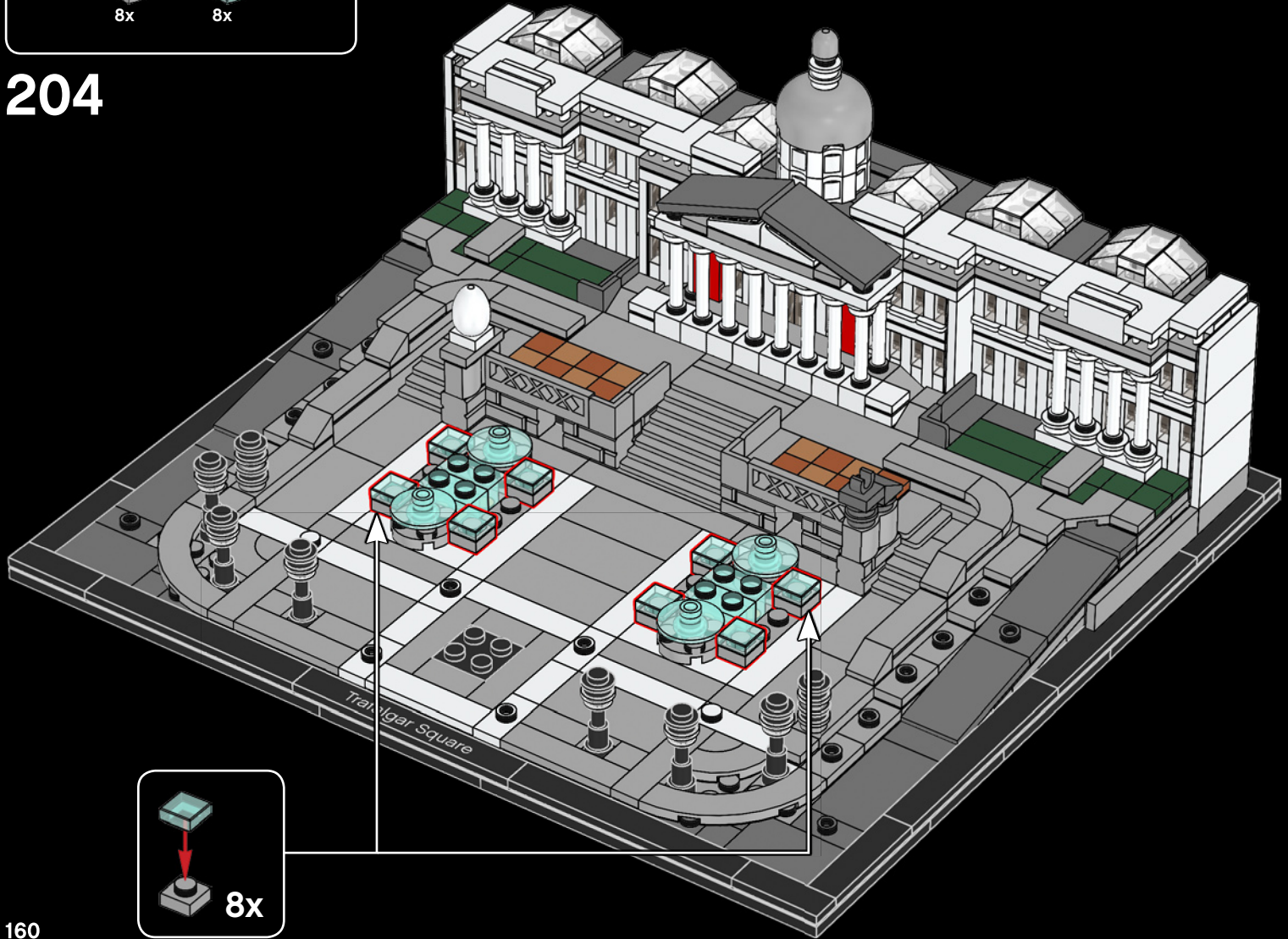

8x





2x

205

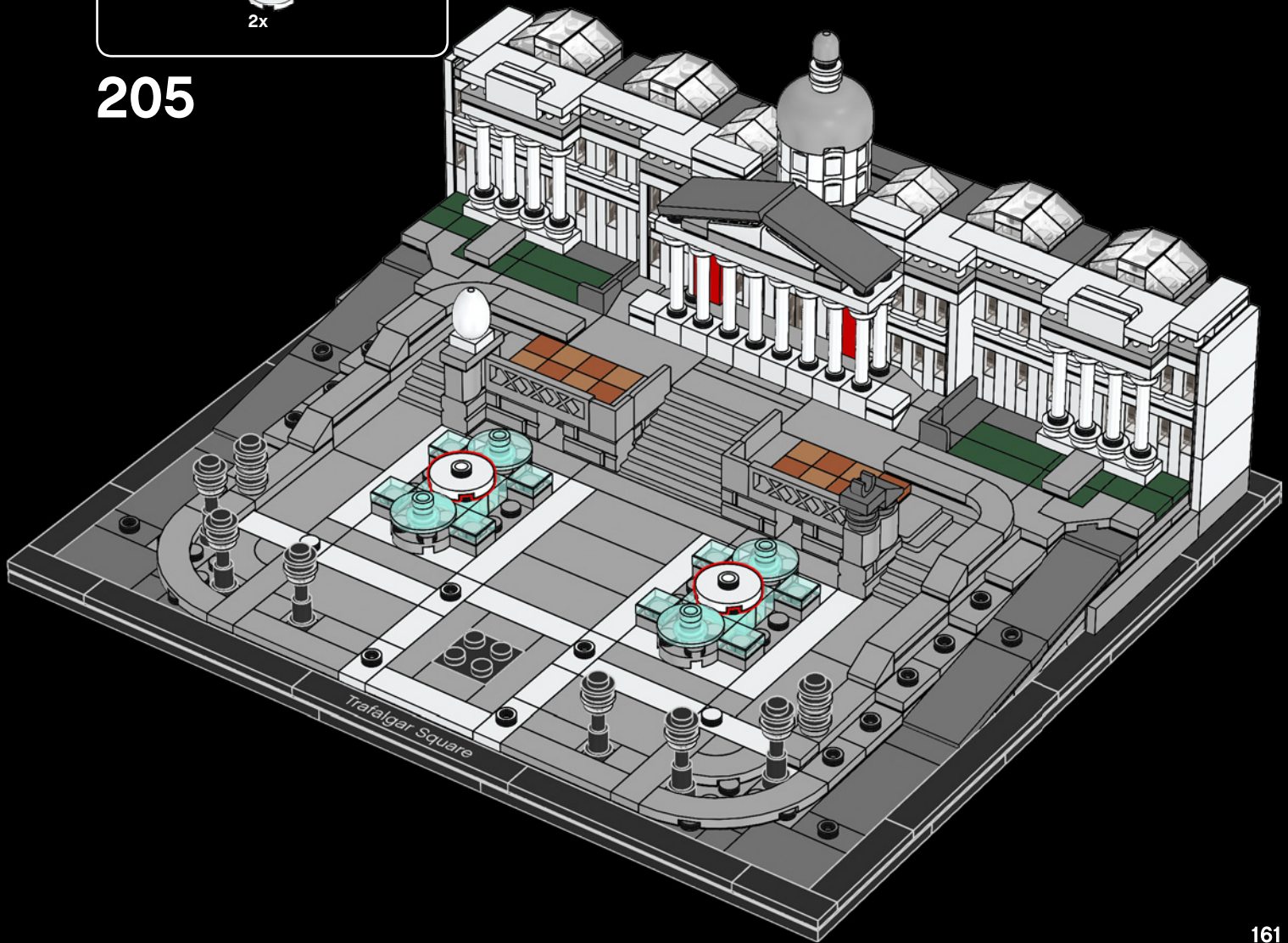



206

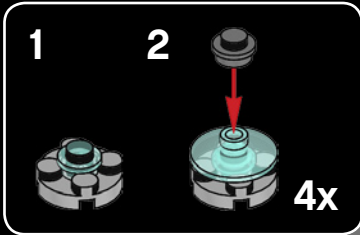





207

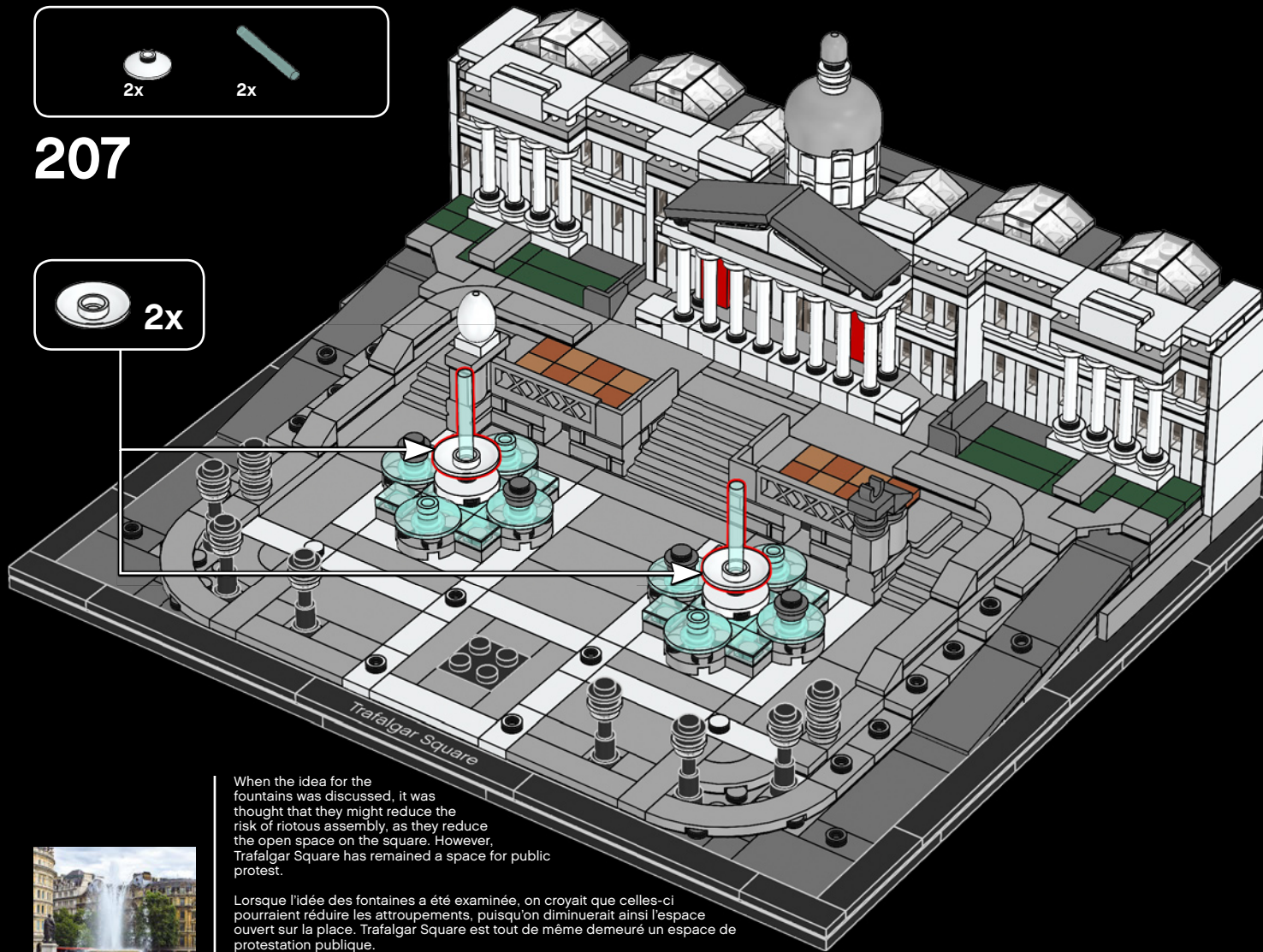

When the idea for the fountains was discussed, it was thought that they might reduce the risk of riotous assembly, as they reduce the open space on the square. However, Trafalgar Square has remained a space for public protest.

Lorsque l'idée des fontaines a été examinée, on croyait que celles-ci pourraient réduire les attroupements, puisqu'on diminuerait ainsi l'espace ouvert sur la place. Trafalgar Square est tout de même demeuré un espace de protestation publique.

Quando se discutió la idea de las fuentes, se pensó que podrían reducir el riesgo de disturbios, ya que limitan el espacio abierto de la plaza. Sin embargo, Trafalgar Square sigue siendo un espacio para la protesta pública.



1x



2x

# 208

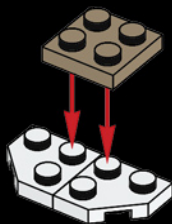

2x

# 209



4x

# 210



1x

# 211





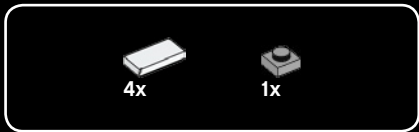

212

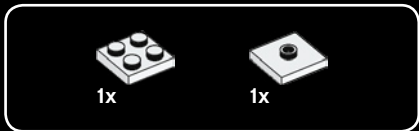
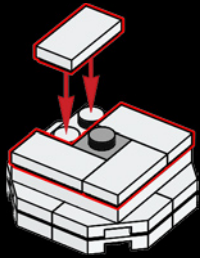

213

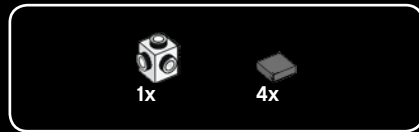
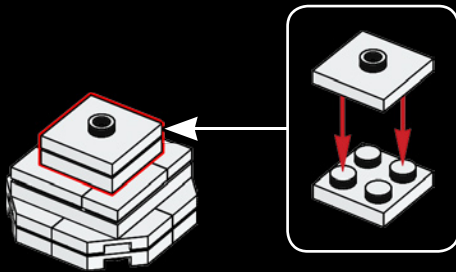

214

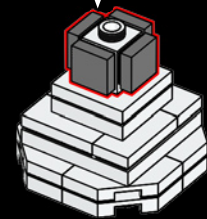
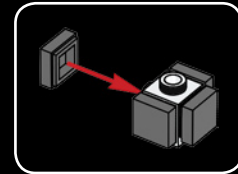



The four bronze reliefs around the base of Nelson's Column show Nelson's most famous battles: St. Vincent, Copenhagen, The Nile, and his death scene on The Victory at Trafalgar.

Les quatre reliefs en bronze entourant la base de la colonne Nelson montrent les batailles de Nelson les plus célèbres : Saint-Vincent, Copenhague, le Nil et sa mort lors de sa victoire à Trafalgar.

Los cuatro relieves de bronce que rodean la base de la Columna de Nelson muestran sus batallas más famosas: San Vicente, Copenhague, el Nilo y Trafalgar, en la que falleció aun habiendo vencido.

215

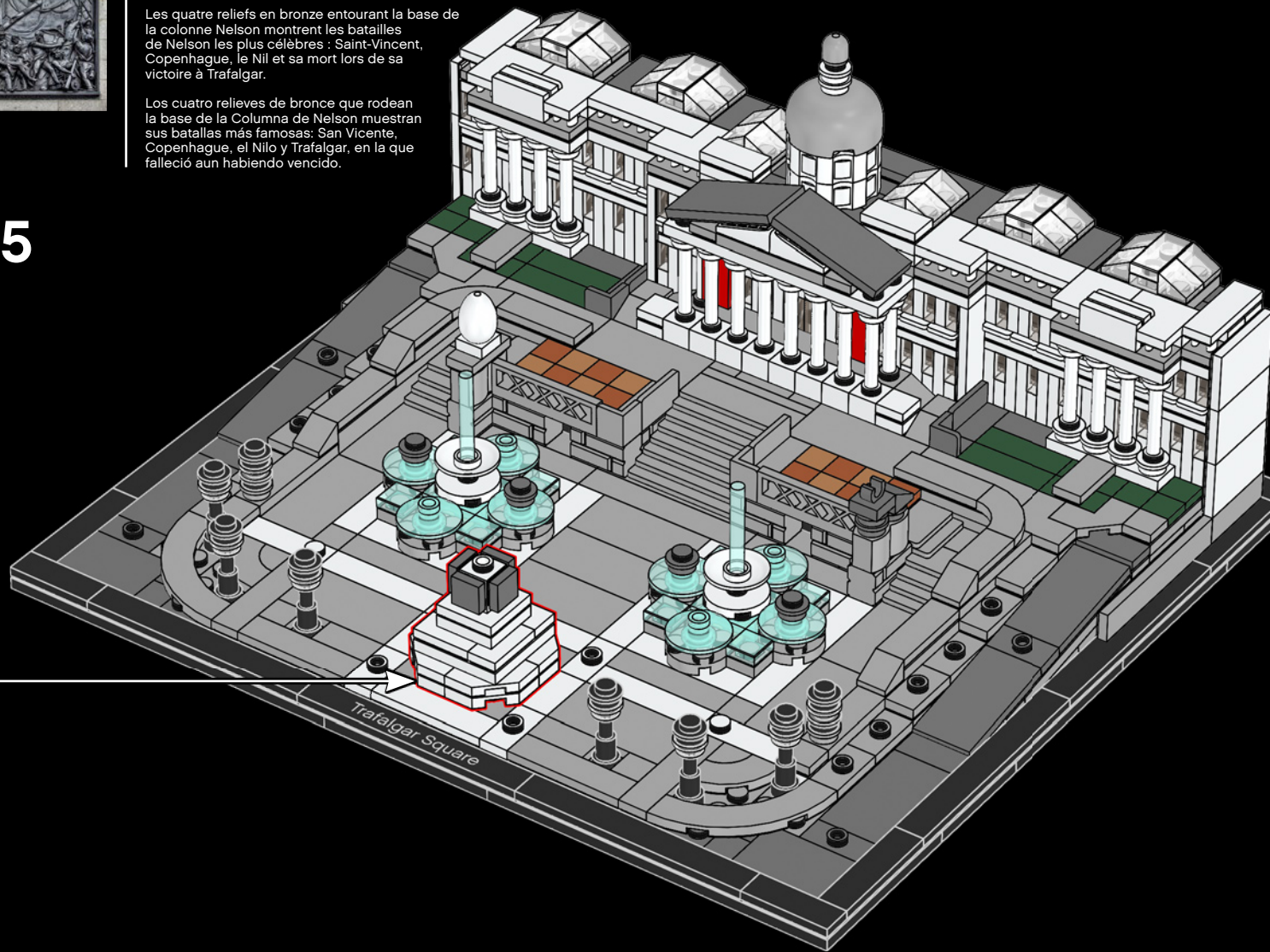

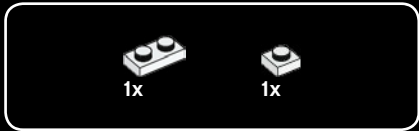

216

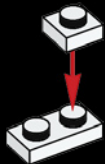

217



218

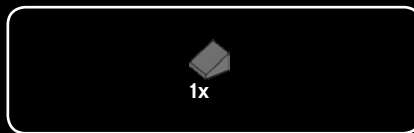
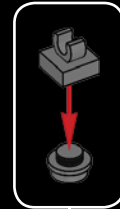

219

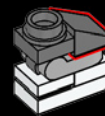

4x



The sculptor of the lions, Sir Edward Landseer, used a real lion that had died as the model, but it took so long to make the piece that the lion decomposed and thus the paws resemble a cat's more than a lion's. Also, a lion's back is actually convex, and not concave, when lying down.

Le sculpteur des lions, Sir Edward Landseer, a eu comme modèle un vrai lion décédé. Il lui a toutefois fallu si longtemps pour réaliser l'œuvre, que le lion s'est décomposé. C'est pour cette raison que les pattes ressemblent davantage à celles d'un chat qu'à celles d'un lion. De plus, le dos d'un lion couché est convexe, et non concave.

El escultor de los leones, Sir Edward Landseer, usó como modelo un león de verdad que había muerto, pero se tardó tanto en confeccionar la pieza que el león se descomposó, por lo que las garras parecen más las de un gato que las de un león. Además, la espalda de un león recostado, en realidad, es convexa y no cóncava.

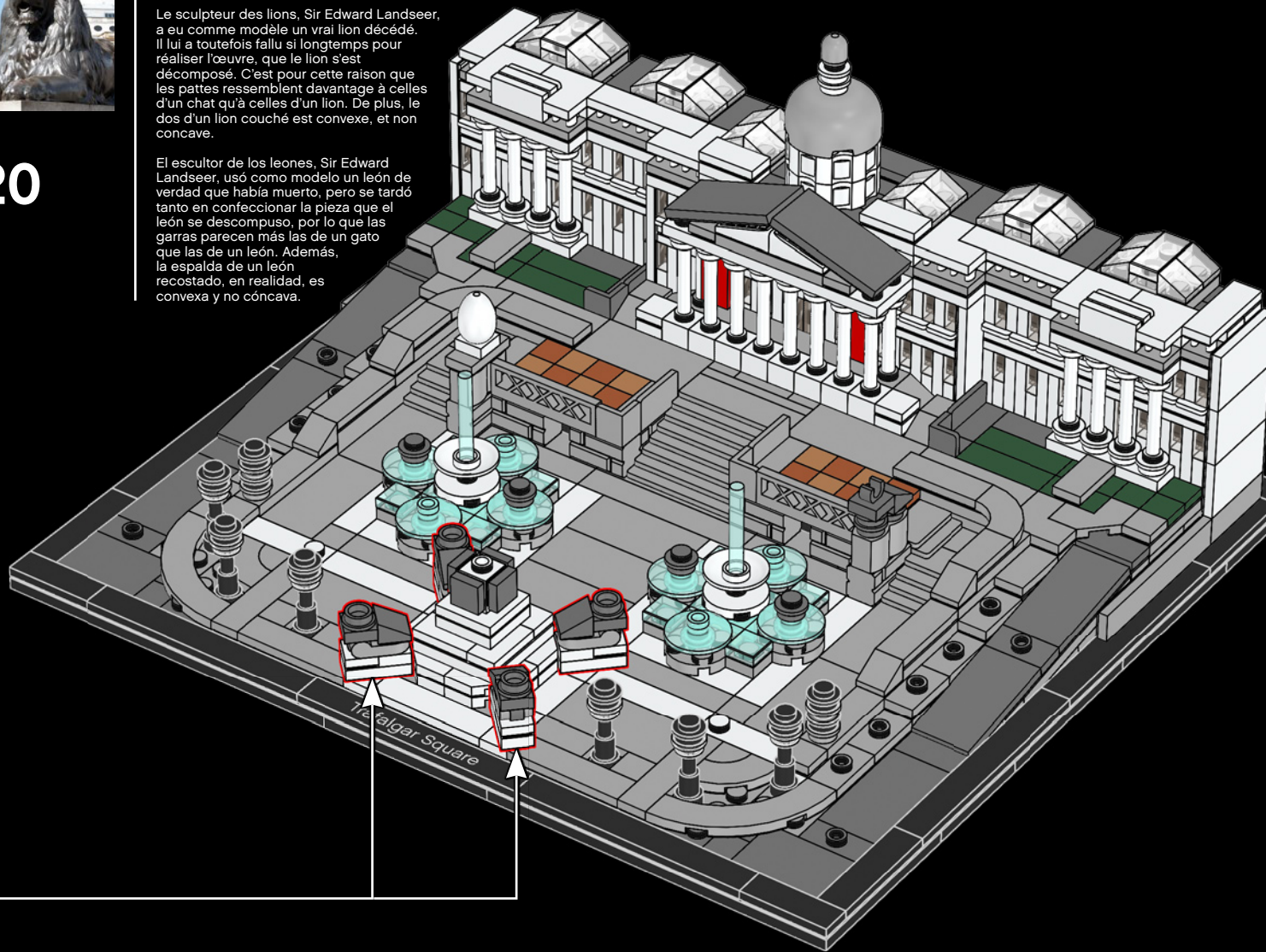

220





4x



2x



2x

# 221

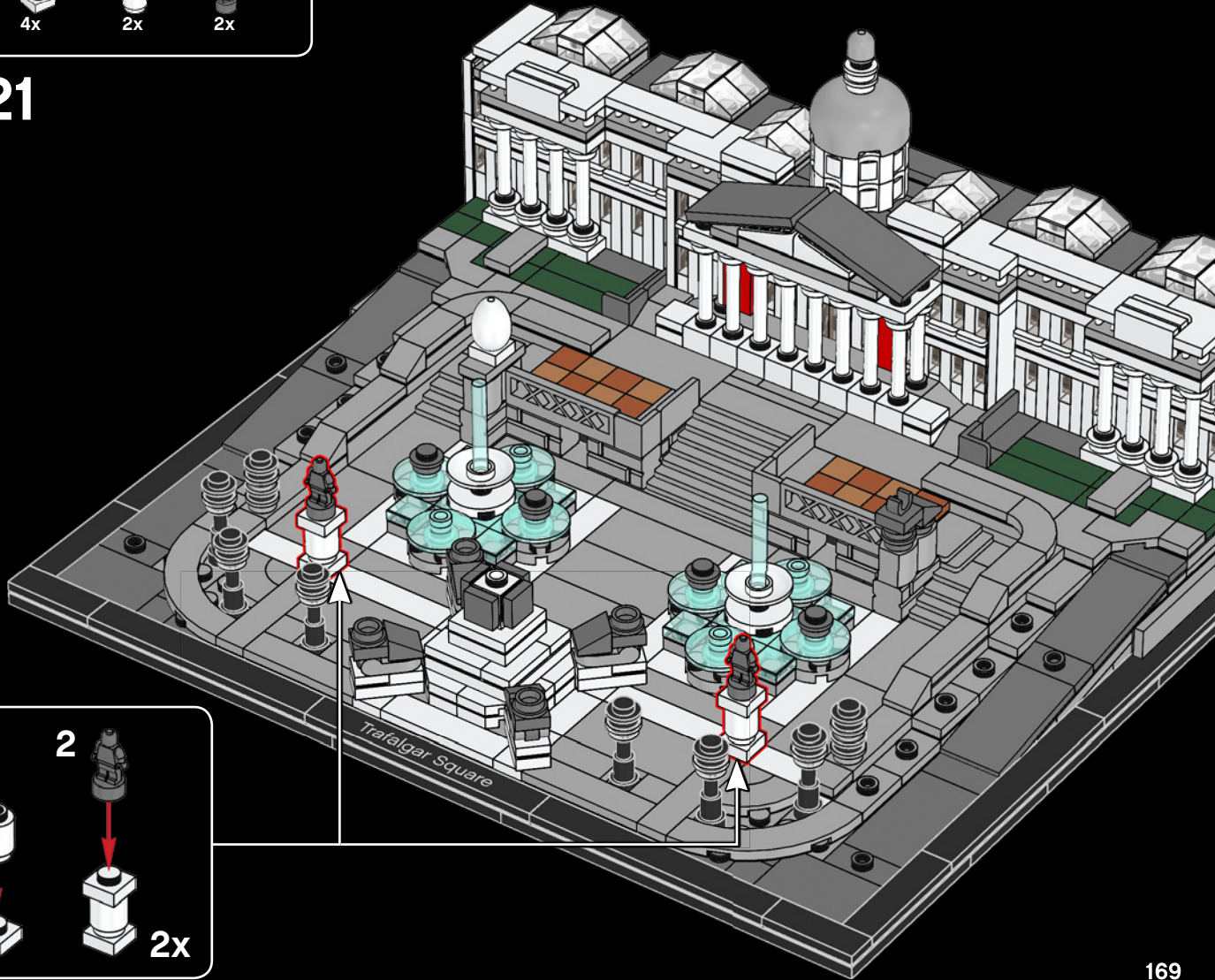

1



2



2x

2x      4x      2x

# 222



1      2

2x



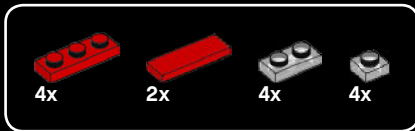

# 223



17 bus routes pass around the square, making it a central hub of London traffic.

Dix-sept lignes d'autobus circulent autour de la place, ce qui en fait une plaque tournante du trafic de Londres.

17 líneas de autobús pasan alrededor de la plaza, lo que la convierte en un eje clave del tránsito londinense.

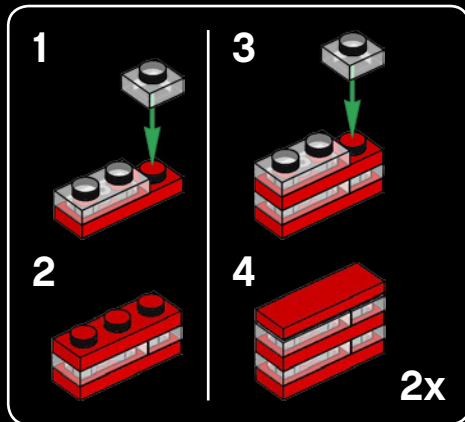
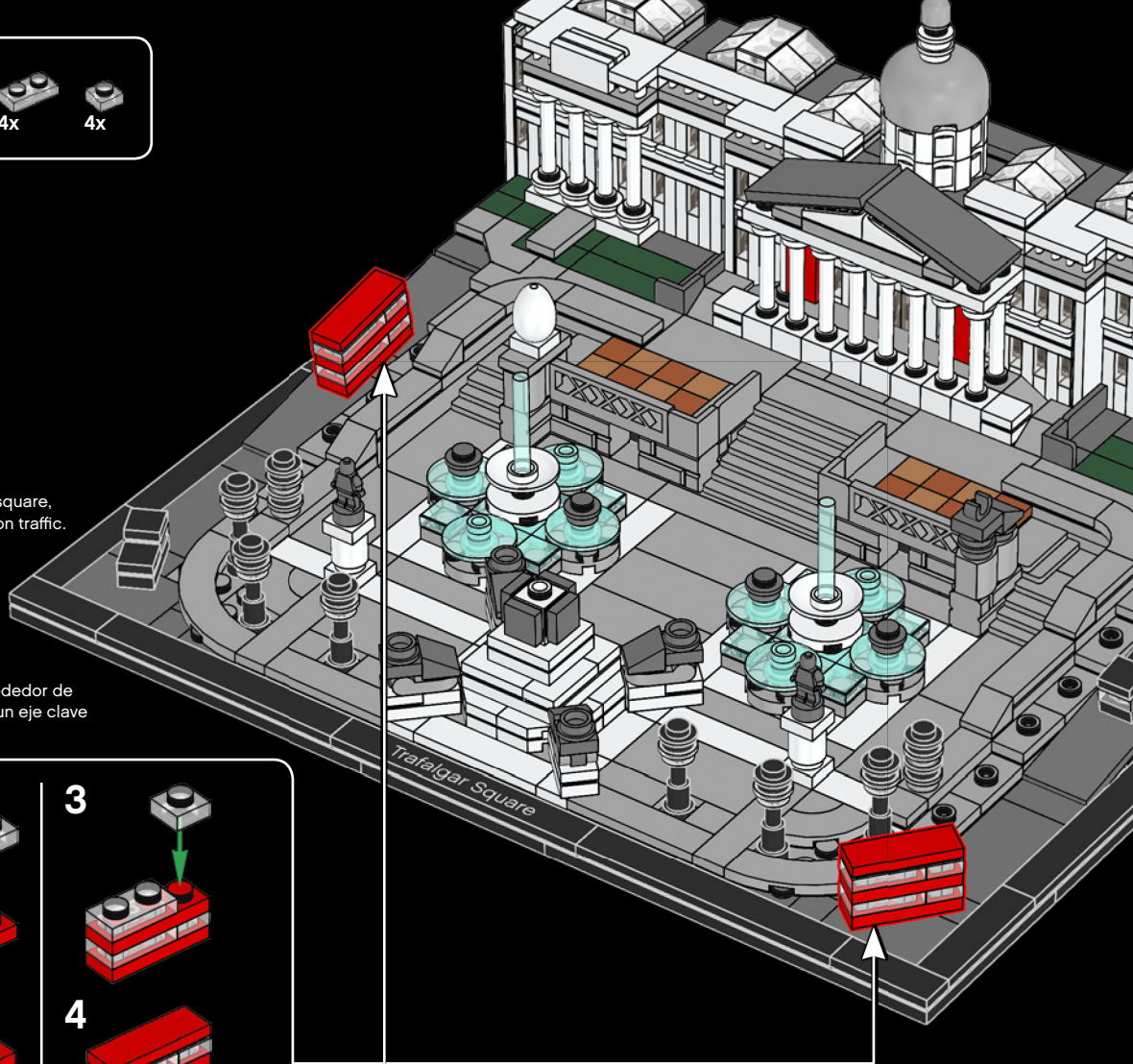



5x



10x



15x



10x



5x



5x

224

1



2



3



4



5x



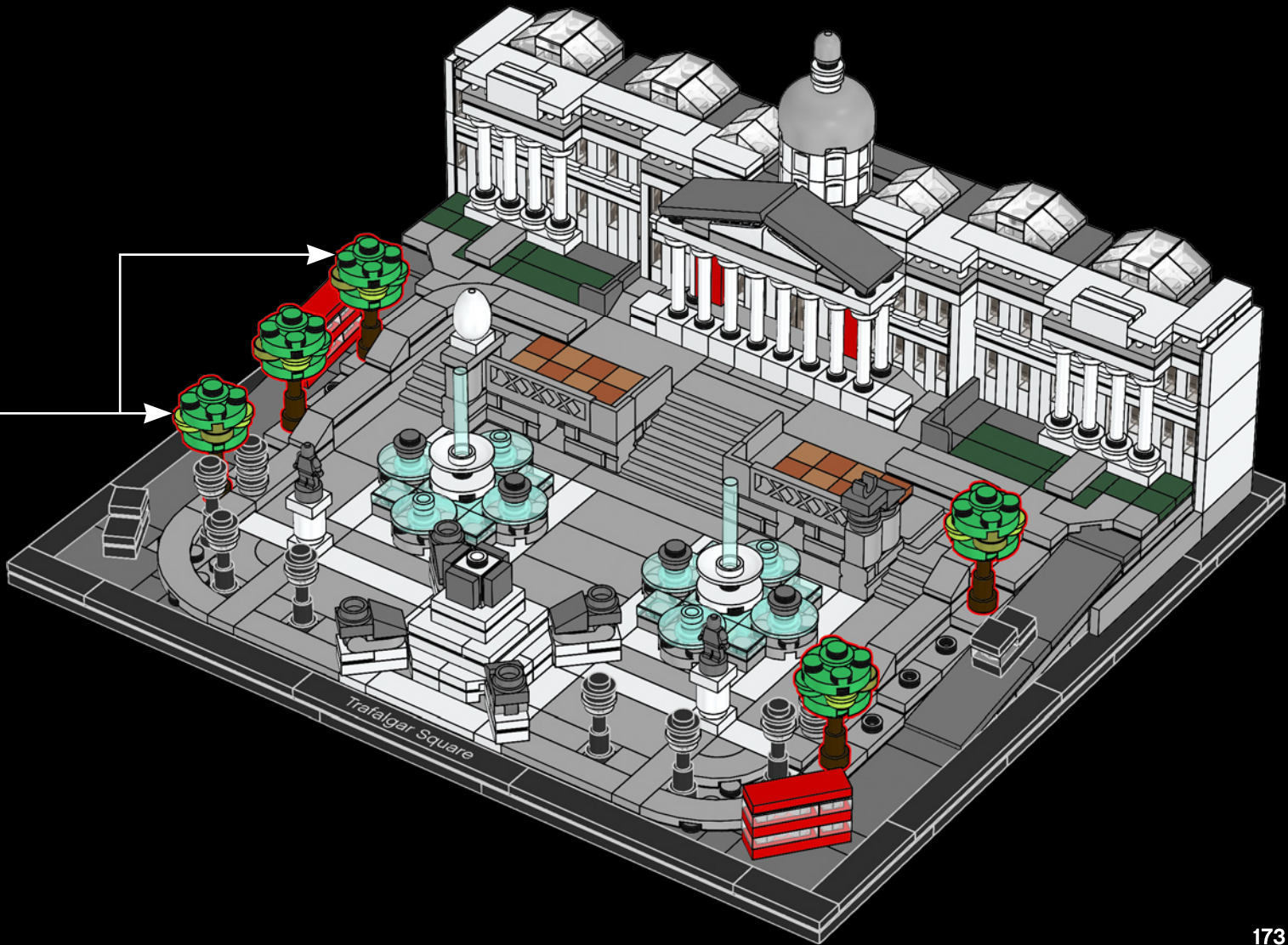



225

1

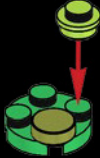

2



3



4

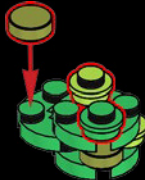

5

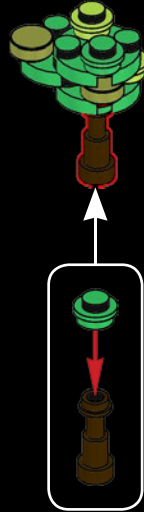

3x





2x



4x



4x



2x



2x



2x

226

1



2



3



4



2x

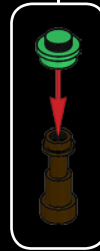





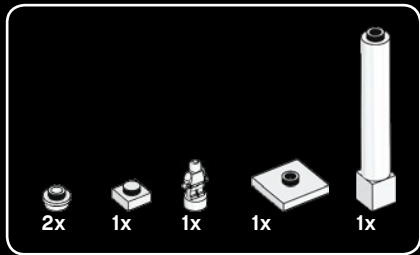

227

1

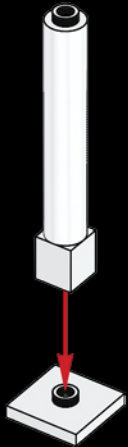

2



3











# LEGO® Architecture – do you like it? Aimez-vous LEGO® Architecture ? LEGO® Architecture: ¿te gusta?

The LEGO Group would like your opinion on the new product you have just purchased. Your feedback will help shape the future development of this product series. Please visit:

Le Groupe LEGO aimerait connaître votre opinion sur le produit que vous venez d'acheter. Vos commentaires nous aideront à concevoir les futurs produits de cette gamme. Veuillez visiter :

The LEGO Group quiere conocer tu opinión acerca del nuevo producto que acabas de comprar. Tus comentarios nos ayudarán a dar forma a los futuros productos de esta serie. Visita:

**[LEGO.com/productfeedback](https://www.lego.com/productfeedback)**

By completing our short feedback survey, you will be automatically entered into a drawing to win a LEGO® prize.

En remplissant ce court sondage sur le produit, vous serez automatiquement inscrit à un tirage au sort pour gagner un prix LEGO®.

Al contestar este breve cuestionario de opinión, participarás automáticamente en el sorteo de un producto LEGO®.



Terms & Conditions apply. Des conditions générales s'appliquent. Sujeto a Términos y Condiciones.

# LEGO® Architecture

The LEGO® Architecture series creatively captures the essence of many of the world's most iconic landmarks while giving you an enjoyable and engaging LEGO building experience.

Whether your interest is in travel, design, history or architecture, these sets are a physical memento of a great trip abroad, a famous building you know well, or a city you still dream of visiting.

Every LEGO Architecture set is designed to be displayed. Much more than just a photo, building and displaying your model on your desk, in the bookcase or on the shelf, lets you be transported every time you admire the view.

La série LEGO® Architecture capture l'essence de nombreux monuments parmi les plus célèbres du monde tout en vous offrant une expérience agréable et stimulante de construction LEGO.

Que votre intérêt porte sur les voyages, le design, l'histoire ou l'architecture, ces ensembles constituent un souvenir tangible d'un voyage mémorable, d'un célèbre bâtiment que vous connaissez bien ou d'une ville que vous rêvez de visiter.

Chaque ensemble LEGO Architecture est conçu pour être exposé. Construire votre modèle et l'exposer sur votre bureau, une bibliothèque ou une tablette vous fera voyager à chaque coup d'œil, bien plus qu'une simple photo ne pourrait le faire.

La línea LEGO® Architecture captura con creatividad la esencia de muchos de los monumentos más populares del mundo y pone a tu alcance una experiencia de construcción gratificante y cautivadora con el sello característico de LEGO.

Ya sea que sientas atracción por los viajes, el diseño, la historia o la arquitectura, estos sets expresan físicamente tus recuerdos de aquel fantástico viaje al extranjero, ese famoso edificio que conoces tan bien o la ciudad que sueñas con visitar algún día.

Todos los sets LEGO Architecture están diseñados para decorar. Mucho más que una simple fotografía, construir y exponer un modelo en tu escritorio, un librero o una repisa te traslada a otro lugar al admirar las vistas.

Follow us on

Suivez-nous sur

Síguenos en



Adam Reed Tucker is the co-developer of the LEGO Architecture product line.

Adam Reed Tucker est le codéveloppeur de la gamme de produits LEGO Architecture.

Adam Reed Tucker es el codesarrollador de la línea de productos LEGO Architecture.



Celebrate the world of architecture  
and collect all the models

Célébrez le monde de l'architecture et  
collectionnez tous les modèles

Celebra el mundo de la arquitectura  
y colecciona todos los modelos

21046  
Empire State  
Building  
L'Empire State  
Building

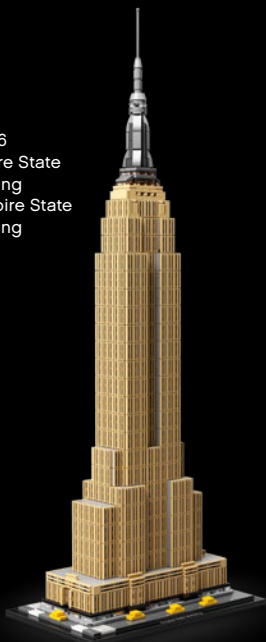

21041  
Great Wall of China  
La Grande Muraille de Chine  
Gran Muralla China



21042  
Statue of Liberty  
La statue de la Liberté  
Estatua de la Libertad



21030  
United States Capitol Building  
Le Capitole des Etats-Unis  
Edificio del Capitolio de Estados Unidos





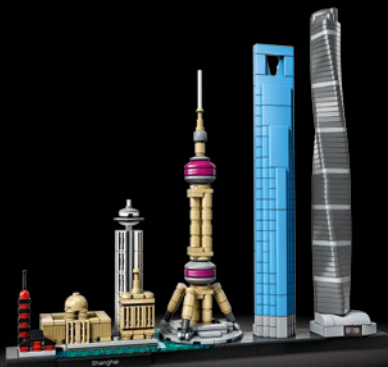

21039  
Shanghai  
Shanghái



21034  
London  
Londres



21047  
Las Vegas



21044  
Paris  
Paris



21028  
New York City  
New York  
Nueva York



21043  
San Francisco

# References

# Références

# Referencias

*Pictures -*  
*Photos :*  
*Fotografías:*

© GettyImages

Customer Service  
Kundenservice  
Service Consommateurs  
Servicio Al Consumidor  
[LEGO.com/service](http://LEGO.com/service) or dial

 00800 5346 5555 ;  
 1-800-422-5346 ;



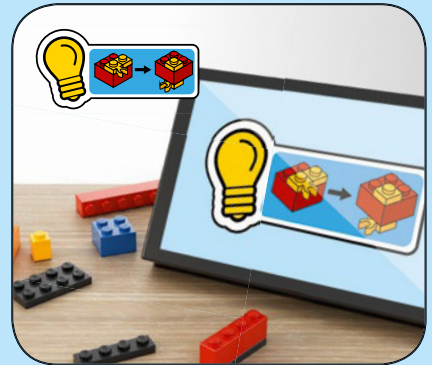



1x 6073432  
2x 306201  
31x 6168642  
1x 6143595  
2x 6254609  
86x 302401  
1x 6253635  
8x 654101  
10x 307001  
2x 6218841  
24x 6167602  
2x 6224811  
1x 6073345

1x 4111971  
2x 4538353  
16x 4613256  
7x 4547489  
2x 474001  
2x 6093053  
11x 6051511  
10x 306901  
54x 302301  
4x 6176240  
1x 4585458  
2x 6023804  
2x 6218823  
2x 6070698

3x 4249563  
18x 6093526  
10x 6218822  
2x 6126046  
1x 6210404  
3x 302201  
6x 6058329  
4x 6168612  
2x 242001  
2x 6263181  
8x 362201  
6x 362301  
2x 4558168

2x 4258358  
6x 6156667  
3x 302101  
2x 300201  
2x 4597131  
14x 243101  
12x 371001  
4x 301001  
3x 6104805  
9x 302001

3x 366601  
6x 663601  
6x 300901  
2x 4243812  
2x 617901  
2x 346001  
4x 416201  
1x 6054973  
4x 4514842

10x 6143431  
2x 302421  
2x 4569056  
5x 306921  
4x 300421  
2x 4515365  
4x 362321  
2x 4533742  
4x 371021  
8x 6240030  
24x 6245250  
6x 6252041  
8x 6240204  
4x 6251294

8x 6240225  
8x 6254256  
8x 6245307  
4x 6244910  
2x 6170187  
1x 6253790  
1x 6253837  
8x 4143005  
18x 4183133  
1x 6208286  
8x 4569058  
23x 403228  
6x 6055171  
4x 6192250  
4x 4650622

6x  
4538456

10x  
614126

4x  
307026

1x  
302426

2x  
4121715

2x  
302326

2x  
6192309

2x  
302226

4x  
4558170

2x  
300226

4x  
243126

1x  
6078886

190

1x  
395726

9x  
416226

1x  
6265021

3x  
303226

2x  
6057902

5x  
303026

4x  
302826

56x  
6252039

4x  
6240219

1x  
6212288

2x  
4211525

2x  
6176433

8x  
4521921

15x  
4211399

2x  
4558953

1x  
6133883

2x  
4215513

2x  
4211389

2x  
4211535

16x  
4211415

2x  
6227897

4x  
6225246

8x  
4211475

2x  
4550325

11x  
6066097

14x  
6146223

2x  
4211388

8x  
6000066

12x  
4211414

6x  
4211397

2x  
6185676

1x  
4612077

4x  
6163990

14x  
4211356

2x  
4599498

12x  
4211445

2x  
6230229

11x  
4560183

1x  
4211385

4x  
4211393

5x  
4211549

4x  
4211438

2x  
4612621

2x  
6163989

10x  
4211353

2x  
6065824

2x  
6177078

4x  
4211387

2x  
4654577

1x  
6263183

6x  
4211429

8x  
4558169

4x  
4211396

8x  
6071299

5x  
4211452

1x  
4211838

2x  
4211462

4x  
4514846

2x  
4211522

2x  
4211360

2x  
4211486

  
2x  
6146192

  
11x  
4210633

  
4x  
4210719

  
5x  
4504378

  
5x  
6071226

  
2x  
6025235

  
8x  
4210848

  
4x  
4210639

  
12x  
6092572

  
2x  
6146225

  
10x  
4211052

  
2x  
4211063

  
2x  
4211094

  
6x  
4211133

  
2x  
6187008

  
8x  
4560184

  
1x  
4210651

  
1x  
4211056

  
1x  
4243831

  
2x  
4210998

  
1x  
4211008

  
1x  
4211134

  
4x  
4257526

  
1x  
6138682

  
4x  
6060800

  
4x  
4523145

  
8x  
6092587

  
2x  
6146221

  
3x  
6132769

  
2x  
4514554

  
2x  
4113988

  
1x  
4609726

  
1x  
6092591

  
4x  
4496699

  
2x  
4528604

  
4x  
4507045

  
1x  
6047415

  
1x  
4633881

  
2x  
6114515

  
13x  
6047015

  
8x  
6177146

  
2x  
6008297

  
10x  
4538950

  
1x  
6240515

  
Customer Service  
Kundenservice  
Service Consommateurs  
Servicio Al Consumidor  
LEGO.com/service or dial

  
: 00800 5346 5555  
: 1-800-422-5346

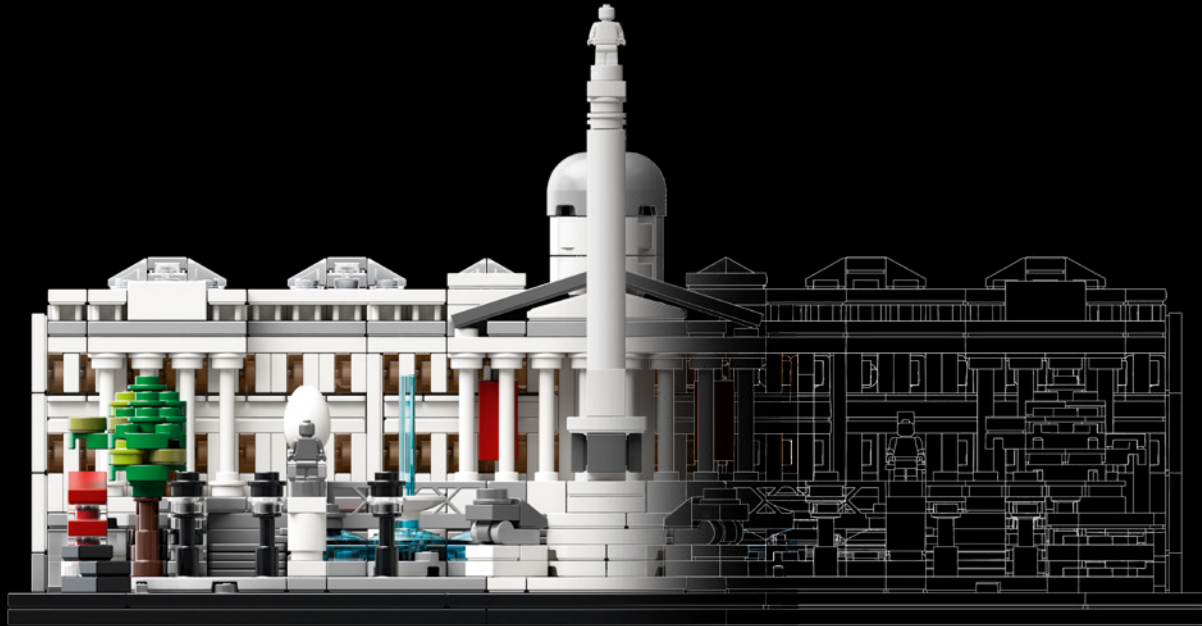

 [LEGO.com/architecture](https://www.lego.com/architecture)

LEGO and the LEGO logo are trademarks of the/son des marques de commerce du/  
son marcas registradas de LEGO Group. ©2019 The LEGO Group. 6281906

Follow LEGO® Architecture on  
Suivez LEGO® Architecture sur  
Sigue a LEGO® Architecture en

